

AFMS F-CPVA

Airplane Flight Manual Supplement

- Radio KRT2

- ACL Anti-collision light

- Flarm

- S100



KRT2

VHF Communication Transceiver

Standard, Landscape, Portrait



- Part No 285942 = KRT2-S (Standard)
- Part No 285945 = KRT2-L (Mini Landscape)
- Part No 286048 = KRT2-P (Mini Portrait)
- Part No 285946 = KRT2-RC (Remote Control)

Operation- and Installation Manual



Record of Revisions

Revision	Date	Chapter(s)	Topic
0100	24.03.2017	all	Initial Release
0101	16.01.2018	6.3, 7.1	FCC supplements, chap. 7.1 (periodic maintenance) amended

Table 1: Record of Revisions



Service Bulletins (SB)

Service Bulletins must be inserted in the manual and added to this table.

No SB	No Rev.	Release date	Date added	Name

Table 2: Service Bulletins



Table of Contents

Record of Revisions	2
Service Bulletins (SB)	3
1. GENERAL	7
1.1 Symbols	7
1.2 Acronyms	7
1.3 Customer Service	8
1.4 KRT2 Transceiver properties	8
2. Installation limitation	9
2.1 Installation	9
2.2 Aircraft Radio	9
2.3 Quantitative safety objective identification	9
2.4 Deviations	9
3. CONTROL general	10
3.1 Control elements overview	10
3.2 Display	14
3.3 Menu levels	15
3.4 Self-test error reports	15
4. OPERATION	16
4.1 General	16
4.2 ON / OFF switching	16
4.3 Frequency selection	17
4.3.1 Direct frequency selection	17
4.3.2 Frequency selection from favourites list	18
4.3.3 Storing and editing favourites	18
4.4 AUD – Audio menu	20
4.4.1 VOL – Volume	20
4.4.2 SQ – Squelch	20
4.4.3 VOX – Intercom voice trigger level setting	21
4.4.4 Manual Intercom	21
4.4.5 TXm – PTT switch selection	21
4.4.6 INT – Intercom volume	22
4.4.7 EXT – External audio input volume	22
4.4.8 DIM – Display brightness	22
4.4.9 BAT – Battery test	23
4.4.10 SIT – Side tone	23
4.4.11 MIC – Setup	23
4.4.12 Menu lock	25
4.5 DUAL watch	26
4.6 Transmitter Operation	27
4.6.1 Two PTT configuration	28
4.6.2 Self-Test monitor	28
4.6.3 Optical side tone	28
4.7 Resetting to factory settings	29
4.8 SET UP - Menu	29
4.8.1 ERASE – erasing of favourites list	30
4.8.2 Channel spacing	30
5. Remote Control	31
6. Installation	32
6.1 Installation hints	32
6.2 Telecommunication data	32



6.3	FCC related issues	33
6.3.1	Radiofrequency radiation exposure Information:	33
6.3.2	Note:.....	33
6.3.3	Compliance.....	33
6.3.4	Modifications.....	33
6.4	Scope of delivery	34
6.5	Unpacking and inspecting the equipment	34
6.6	Mounting	34
6.7	Electrical connections	34
6.7.1	Microphone connection.....	35
6.7.2	Speaker & open microphone:	36
6.7.3	Earphone connection.....	36
6.7.4	External audio input.....	36
6.7.5	Speaker connection	36
6.8	Final audio setup	37
6.8.1	For glider flights	37
6.8.2	For motor gliders dual seaters	37
6.8.3	For motor planes	37
6.9	Wiring	38
6.9.1	Wire Gauges.....	38
6.9.2	Connector Pin-Configuration.....	38
6.9.3	General hint.....	39
6.9.4	Wiring diagrams.....	40
6.9.5	Wiring for dynamic microphones.....	46
6.9.6	Connection support ST1 mating connector	46
6.10	Antenna.....	47
6.10.1	Antenna selection	47
6.10.2	Installation recommendation	47
6.11	Microphone general.....	48
6.12	Post-Installation Check.....	48
6.13	Starting Up	49
6.14	Accessories	49
6.15	Drawings	49
6.15.1	Dimensions.....	49
6.15.2	Installation directions	51
7.	Maintenance	52
7.1	Periodic Maintenance	52
7.2	Repair.....	52
7.3	Cleaning	52
8.	ANNEX.....	53
8.1	Frequency / channel - schedule.....	53
8.2	Technical Data	54

List of Figures

Figure 1: KRT2-S Front View	10
Figure 2: KRT2-P front view	11
Figure 3: KRT2-L front view	12
Figure 4: KRT2 active & standby frequencies	26
Figure 5: KRT2 TX & RX operations	27
Figure 6: Headsets.....	35
Figure 7: Connector pinout.....	38
Figure 8: Remote control pinout.....	38



Figure 9: KRT2 connection support layout 1	46
Figure 10: KRT2 connection support layout 2	47
Figure 11: KRT2-S Dimensions.....	49
Figure 12: KRT2-P, KRT2-L dimensions	50
Figure 13: KRT2-RC remote control dimensions	50
Figure 14: KRT2-S panel cutout.....	51
Figure 15: KRT2-P, KRT2-L panel cutout.....	51



List of Tables

Table 1: Record of Revisions	2
Table 2: Service Bulletins.....	3
Table 3: Acronyms	7
Table 4: KRT2 Controls.....	13
Table 5: KRT2 Display	14
Table 6: KRT2 Menu Levels.....	15
Table 7: KRT2 Built In Tests (BIT)	15
Table 8: KRT2 Menu Lock	25
Table 9: Telecommunication data	32
Table 10: Scope of delivery.....	34
Table 11: Frequencies	53
Table 12: Technical Data General.....	54
Table 13: Technical Data Transmitter	55
Table 14: Technical Data Receiver	55

1. GENERAL

This manual contains information about the physical, mechanical and electrical properties as well as a description for the operation and installation of the VHF airborne transceiver KRT2.

1.1 Symbols

	<p>WARNING Non-compliance may cause personnel injury due to radiation or fire.</p>
	<p>CAUTION Non-compliance may cause damage or incorrect operation of the transceiver.</p>
	<p>INFORMATION</p>

1.2 Acronyms

Abbreviation	Description	Definition
BAT	Battery (Electrical)	Check DC source
DIM	Dimming	Display brightness setting
EXT	Exterior / External	External Audio input level setting
INT	Intercom level	Intercom volume level setting
PTT	Push-To-Talk	Transmitter activation
RC	Remote control	KRT2-RC remote control for KRT2
SQ	Squelch	Squelch setting
VOX	Voice operated intercom	Voice level setting for intercom activation

Table 3: Acronyms

1.3 Customer Service

In order to process returned units most expeditiously, please use the email support.krt@tq-avionics.com on the website www.tq-avionics.com



Suggestions which will improve this manual are very much appreciated at: info@tq-avionics.com.



Information concerning software updates is available under support.krt@tq-avionics.com.

1.4 KRT2 Transceiver properties

- VHF airborne transceiver
- Frequency range 117.975 to 137.000 MHz
- Channel spacing 8,33 / 25 kHz (2278 channels)
- Fast channel selection
- 2 separate microphone inputs (standard or dynamic)
- Audio-input for other audio devices
- Installation: Standard panel cut-out (57 mm)
- Integrated Intercom
- 100 user definable frequencies with up to 8 character/spaces identifiers



Continuous transmissions will be turned off after 2 minutes.
(Stuck microphone function)



2. Installation limitation

The conditions and tests required for (E)TSO approval of this article are minimum performance standards. It is the responsibility of those installing this article either on or within a specific type or class of aircraft to determine that the aircraft installation conditions are within the (E)TSO standards. (E)TSO articles must have separate approval for installation in aircraft.

2.1 Installation

For installation hints, data, electrical connections and mounting instructions please see section 6 “[Installation](#)”.

2.2 Aircraft Radio

The KRT2 was designed as a closed unit for installation in a cockpit environment of the general aviation with the following limitations:

Installation must be in accordance with the applicable EASA or FAA requirements.

The classification of the software approval is suitable for aircraft type.

The failure classification identified in accordance with FAA AC 23.1309-1D is:

MINOR

The Software level is:

LEVEL D

2.3 Quantitative safety objective identification

In accordance with EASA regulations, the goal is a safety objective for the VHF COM radio in the KRT-2 VHF Communication Transceiver System of $1 \times 10E-4$ per flight hour for Class I airplanes and $1 \times 10E-5$ per flight hour for Class II Airplanes.

2.4 Deviations

None

3. CONTROL general

3.1 Control elements overview

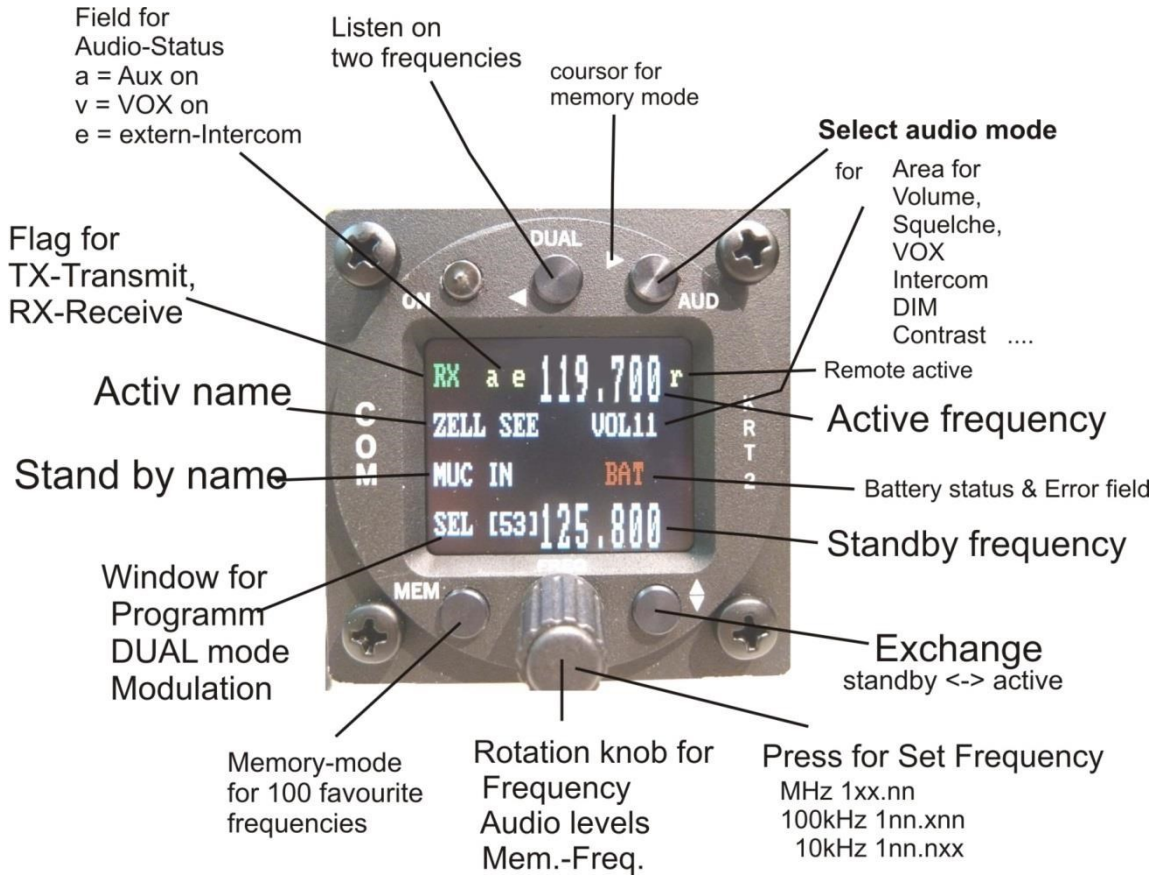

Figure 1: KRT2-S Front View

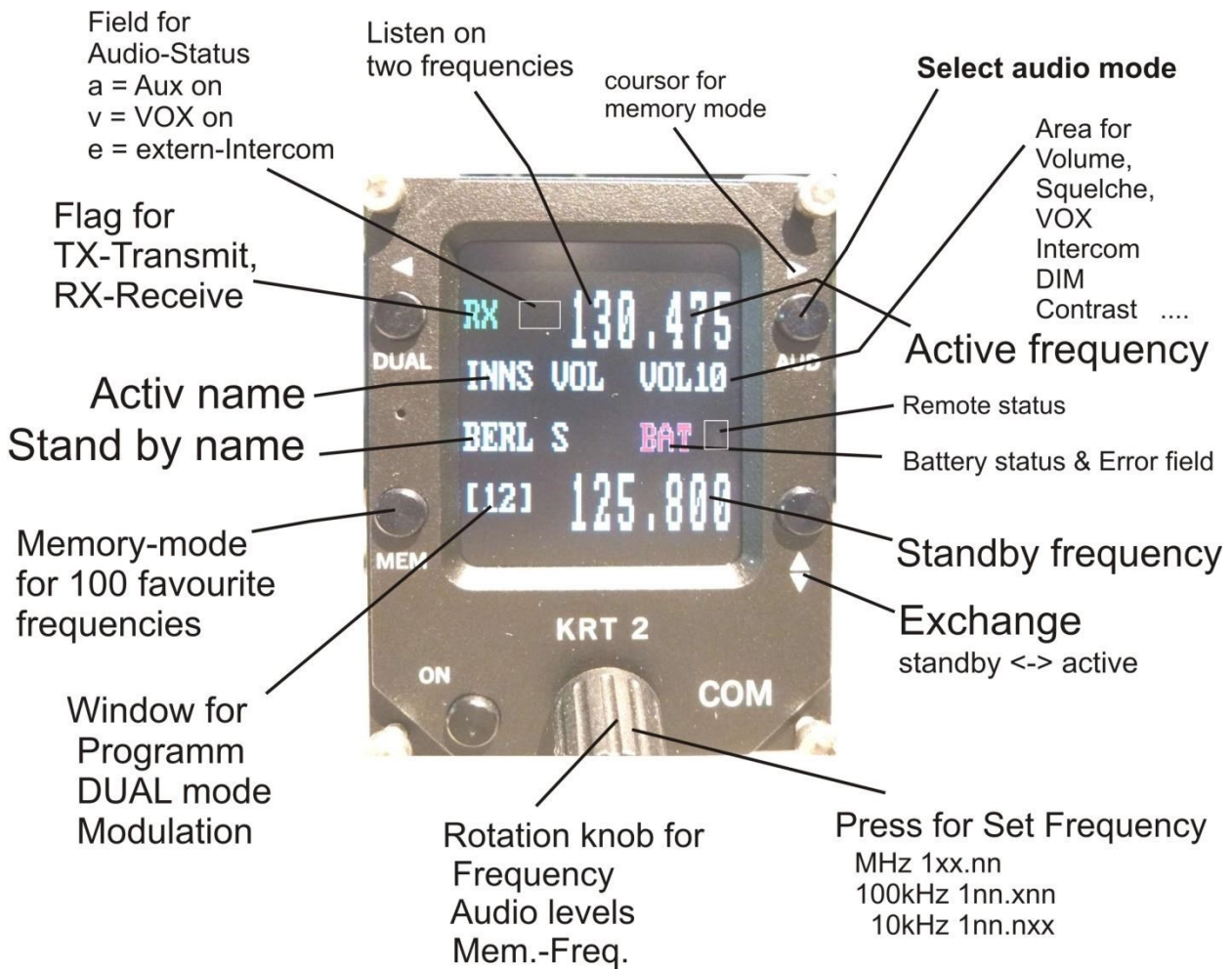

Figure 2: KRT2-P front view

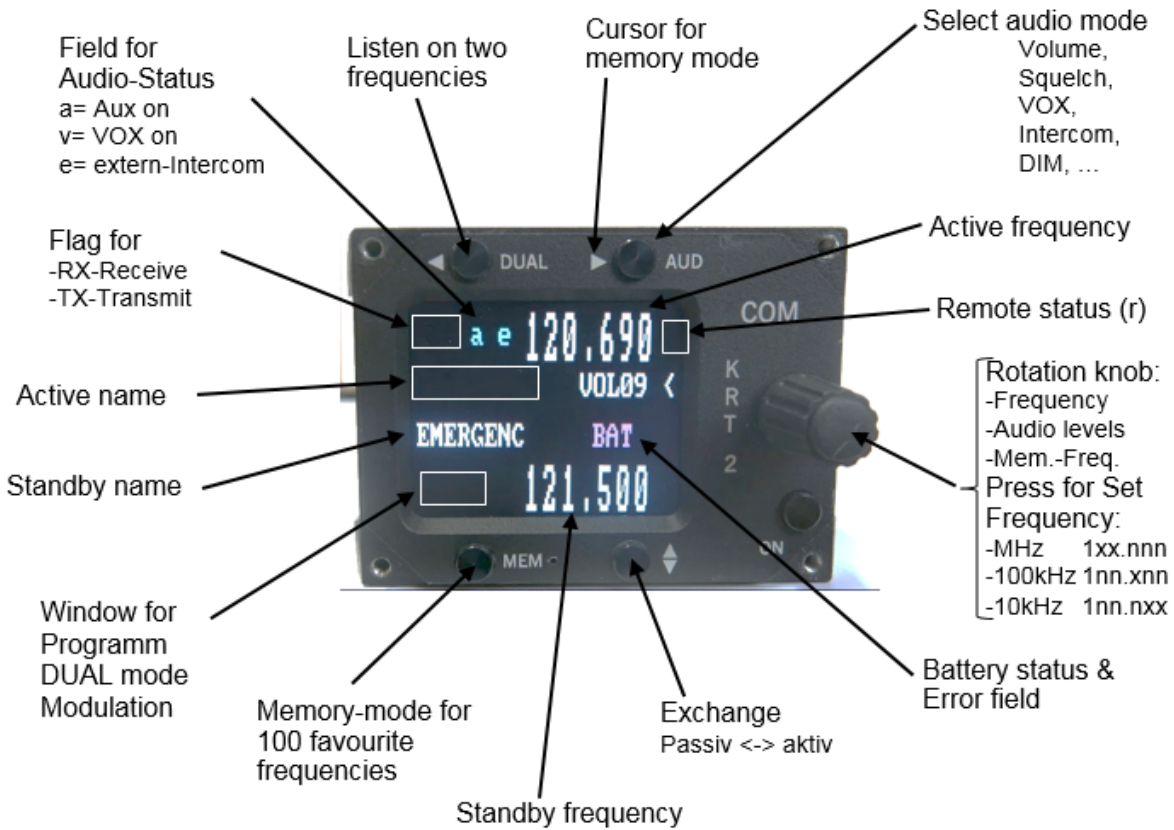

Figure 3: KRT2-L front view

All functions and performances of the normal size unit (57mm round) and the Portrait format (Mini) are identical.

The only differences are the text areas on the display Compare Figure 2: KRT2 Front view and Figure 3: KRT2 Mini Front view for more details.







Button	Function	Usage
	ON / OFF	Self-locking switch
	DUAL WATCH	<ol style="list-style-type: none"> 1. Scanning between the Active and Standby frequencies 2. Positioning cursor to the left when programming the station identifier
	AUDIO SELECT	<ol style="list-style-type: none"> 1. Stepping through the audio menus 2. VOL SQ VOX TX INT EXT DIM CON SIT and MIC 3. Positioning cursor to the right when programming the station identifier
	FAVORITES	<ol style="list-style-type: none"> 1. Frequency and identifier selection from the favourites list 2. Programming of favourites (frequency and identifier)
	EXCHANGE	Exchange of the Active and Standby frequencies
	TURNING KNOB	<p>Pressing for Selection of the frequency range to: MHz, 100kHz, 10kHz</p> <p>Toggles between frequency and identifier when programming the favourites</p> <p>Sets all variable values in any menu</p> <ul style="list-style-type: none"> • Volume setting of headsets and speakers • MHz/kHz selection of the standby • frequency in 3 different ranges • Favourite selection • Alpha character selection when programming favourites • Change of microphone settings

Table 4: KRT2 Controls



3.2 Display

Indication	Meaning	Remark
RX	Reception	RX is displayed during reception (squelch opened)
TX	Transmission	Transmitter operates normally
Te	Transmitter was turned off automatically after 2 min continuous operation	
119.700	Frequency	
ZELL SEE	Frequency station identifier	Displayed when frequency and identifier are stored in the favourite list
MUC IN	Standby frequency station identifier	Displayed when frequency and identifier are stored in the favourite list
VOL	Receiver volume level (default after a certain time delay)	When AUD is pressed the corresponding Audio Menu item and setting is displayed
DUAL	DUAL function is activated	DUAL function is deactivated by DUAL, FREQ or MEM
[03] (MEM)	Favourite list index (0-99)	When frequency and identifier are stored at this index ex:[03] they are displayed
125.100 upper	Active frequency	Displayed in large fonts.
125.800 lower	Standby/DUAL - frequency	Displayed in large fonts.
<	The pointer indicates what the turning knob will change VOL SQ VOX.....etc. Standby frequency	Arrow is positioned according to the button pressed (AUD or FREQ)
BAT	Supply voltage is low <10,5V	Low or defective battery / generator.
A-match	Antenna error	Bad antenna match
a v e	Status of certain Audio menu functions	a = AUX. Input active v = VOX active e = external Intercom switch active

Table 5: KRT2 Display



3.3 Menu levels

Displayed	Signification	Remark
VOL	Volume	Default
SQ	Squelch	
VOX	Voice operated	Voice operated intercom
DIM	Display brightness	
BAT(tst)	DC source check	
INT	Intercom - Volume	
EXT	Volume of external devices	
TX(m)**	PTT button selection	Left/Right/Both
SIT	Side tone	During transmitter operation
MIC	Setup-Menu for Microphones	Service-Menu without radio operation.

Table 6: KRT2 Menu Levels

3.4 Self-test error reports

Display	Meaning	Remark
Er_PLL	Internal error, no transmission	Return the transceiver for maintenance
Er_ADC	Internal error, operation limited	Return the transceiver for maintenance
Er_FPA	Internal error; unit not usable	Return the transceiver for maintenance
Er_I2C	Internal error; unit not usable	Return the transceiver for maintenance
Er_D10	Internal error; reception corrupt	Return the transceiver for maintenance
Error_3V3	Internal error; unit not usable	Return the transceiver for maintenance
Key_Block	Internal error; unit not usable	Return the transceiver for maintenance

Table 7: KRT2 Built In Tests (BIT)



4. OPERATION

4.1 General

In the normal operating mode in which the turning knob always is connected to the volume (VOL). The normal operating mode can be left by pressing the AUD, FREQ or MEMORY button.

When not in the normal mode and there is no pilot action for more than 10 seconds the unit returns to the normal mode.

4.2 ON / OFF switching

ON / OFF switching is done by pushing the self-locking switch.

After power up the following display will be displayed:



Device-name
KRT2

Software Version e.g. V8.6

(Example)

The unit starts in the normal operating mode using and displaying the data last used.

4.3 Frequency selection

There are two different frequency selection methods:

- Direct Input
- Selection from the favourite list (index 0-99)

4.3.1 Direct frequency selection



The Standby-Frequency is set with the turning knob in 3 different ranges. The selected range is highlighted and can be changed with the **FREQ** button. Frequency ranges are:

1xx.nnn

1nn.xnn

1nn.nxx

Press the **FREQ** button once or several times until the desired frequency range is highlighted. The unselected digits are displayed as dotted digits.



When the pointer is not next to the Standby Frequency window, it will be repositioned with the first pressing of the **FREQ** button.



Exchanges the Active and Standby frequencies.

When the Exchange button is not pressed, the Standby frequency display will return to its normal appearance after 20 seconds.

4.3.2 Frequency selection from favourites list

By pressing  and operating the turning knob a specific favourite list position can be accessed [xx] (xx = index 0 ... 99). When frequency and station identifier have been defined, they will be displayed in the Standby and station identifier windows.

The favourite identifiers list can be sorted in alphabetic order (see 4.3.3 Storing and Editing Favourites).

To exit this menu, press the  key.

The selection procedure can be terminated with either the AUD or FREQ buttons. Without pressing any of these buttons the unit will return to its normal operating mode after about 15 seconds.

4.3.3 Storing and editing favourites

Any displayed Standby Frequency can be associated with an identifier and both can be stored as favourites in the favourite list. The frequency and identifier of a favourite can be edited.

First press the  button and go to the desired favourite list position to be edited using the turning knob (index [00 ...99]).

Press the MEMORY button a second time and „-EDIT-„ will show up in the program window.



In the identifier window a blinking cursor will show up under the extreme left character.

The turning knob selects the desired character. The AUD button positions the cursor one character to the right. The DUAL button positions the cursor one character to the left and simultaneously erases this character.

The station identifier can consist of a maximum of 8 characters/spaces.

To change frequency just press the FREQ button and follow the normal direct input procedure to edit the frequency, see “4.3.1 Direct Frequency Selection”.

To quit the frequency input press the MEMORY button again in order to go to the station identifier win-

down for editing the identifier if required. Using the buttons FREQ and MEMORY it is possible at any time to toggle between identifier and frequency inputs.

Keep in mind the watch dog timer which will terminate the input mode after 15 sec.

Termination and Save

To save the entered identifier, press the  key as the cursor is on the station name, "SAVE" will appear and the system will go back to the favourite selection.

A **sorting process** can be activated by pressing the "MEM" button again from the EDIT-mode.

"SORT?" will be displayed for 20 seconds and it should be activated with  or skipped with "MEM".



When activated all 99 favourites will be sorted in alphabetical order and the process can take several minutes.

During the sorting procedure "RUN nn" is displayed in the program window, with nn being the running index.

After a 6 seconds time out or by ending the sort, the transceiver resumes its normal operating mode.

When the "MEM" button is pressed at the time "RUN nn" is displayed, the sorting procedure is terminated. The favourite list is then partially sorted and the transceiver resumes its normal operating mode.

Example:

1. Button MEM -> SEL [23] = Select location
2. Button MEM -> -EDIT- = Input of name
 - Rotation knob to select the characters
 - For cursor use (AUD) (DUAL)
 - Frequency setting -> press rotating button
 - Use button MEM to go back to -EDIT-
3. Button  -> shortly SAVE -> back to 1.) (do nothing = cancelling)
4. Button MEM -> question for "SORT?" Yes = , No = MEM or do nothing.

If the function is abandoned before completion, it will be exited after a 6 seconds time out with no activity. The data will not be saved.

4.4 AUD – Audio menu

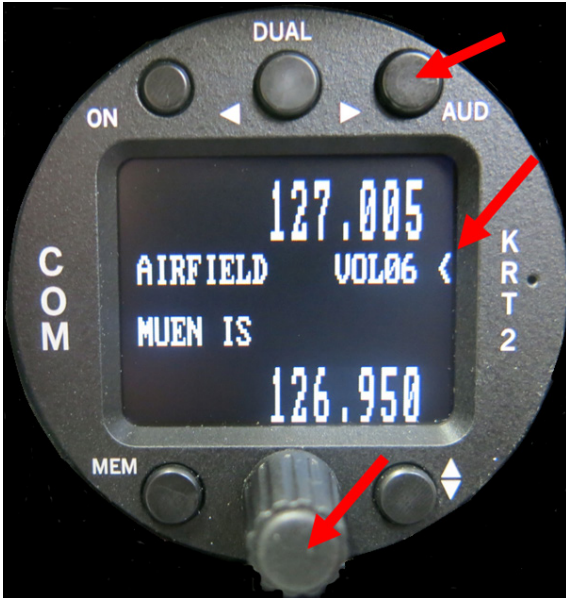

Any action in the Audio Menu requires the pointer (<) to be next to the Audio menu window (see picture). When the pointer is next to the Standby frequency window, the pointer can be repositioned by pressing the AUD button once.

VOLnn is the Audio menu default display. No action on any control for more than 10 seconds will result in the VOLnn being displayed.

Audio Menu items can be accessed in the following order by repeatedly pressing the AUD button.

VOL (default), SQ, VOX, TXm**, INT, EXT, DIM, BATtst, SIT, MIC

4.4.1 VOL – Volume

Turning the turning knob changes the receiver volume.

VOLnn Range: 01 – 20



The VOL setting only concerns the receiver and not the intercom system. Intercom volume values are set in the INT audio menu.

4.4.2 SQ – Squelch

Pressing the AUD button once enables the turning knob to change the squelch level values.

SQnn Value range: 01 – 10

The Squelch setting is depending on several factors.

For engine driven airplanes an initial setting of 3-5 is recommended. For gliders a setting of 2 is recommended. The lower the Squelch level value the higher is the input sensitivity. A high sensitivity setting is susceptible to noise from other sources like ignition strobe-lights etc.



Standard SQ-level is 3..5. Higher setting will suppress weaker input signals. 01 = Squelch off, 02 = for long range. Squelch does not influence the intercom system.



4.4.3 VOX – Intercom voice trigger level setting

Pressing the AUD button twice enables the turning knob to change the voice level which triggers the intercom.

The intercom voice trigger level must be set to a value which prevents normal cockpit noise from being heard in the earphones. The intercom system should only be activated when talking at a normal voice level into the microphone.

The higher the trigger level the louder the voice must be in order to trigger the intercom system. VOX on condition is indicated by flag “v”.

VOXnn Range: 01 – 10



The larger the value, the louder one must speak in order to activate the Intercom connection.
VOX on condition is indicated by flag “v”.
For installation with loudspeakers set VOX to 10 to switch it off.

4.4.4 Manual Intercom

With cockpit loud background noise or with uncompensated microphones the Intercom can be controlled manually by using an external switch. Therefore the VOX system must be activated permanently by selecting VOX: 01.

To turn off the Intercom the talk switch (default closed) must be opened, which will be indicated by “e”.

Deactivation of the intercom is done with an opened external microphone button (Ground connection to pin 12), this is indicated with an “e” on the display.

This mode only works with a deactivated external audio input (see “4.4.7 EXT – External Audio Input Volume”).

In gliders the VOX has to be set to 10 in order to disable the speaker control.

4.4.5 TXm – PTT switch selection

Pressing the AUD button three times enables the turning knob to enable certain PTT switches.

On transmission the microphone which is related to the PTT-L/R will be enabled. The equivalent indication is TX (TXm**), TX1 (TXm*-) TX2 (TXm-*).

On transmission the PTT-L/R related microphone will be the only one activated.

TXm** *- Left / -* Right / ** Both

4.4.6 INT – Intercom volume

Pressing the AUD button four times enables the turning knob to set the intercom volume.

INTnn Range: 1 – 9

4.4.7 EXT – External audio input volume

Pressing the AUD button five times enables the turning knob to set the external audio input volume. External audio inputs can be audio alarms, voice alarms, Vario, etc. The required level is 200mVpp (6Vpp max).

Activation occurs for settings >00 and will be indicated by “a”.

- 00 = turning off,
- 01 = lowest gain without threshold
- 09 = highest gain with interference suppression threshold.

EXTnn Range: 0 - 9

4.4.8 DIM – Display brightness

Pressing the AUD button six times enables the turning knob to set the display brightness.

DIMnn Range: 01 – 16

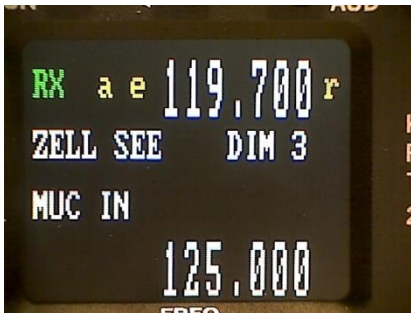

The display consumption at 12V is between 10mA und 70mA. In addition the battery voltage in Volts is indicated.

4.4.9 BAT – Battery test

Pressing the AUD button seven times enables the turning knob to display the battery voltage.



4.4.10 SIT – Side tone

Pressing the AUD button eight times enables the turning knob to set the side tone volume (for gliders has to be set to 01).

SITnn Range: 1 – 9

4.4.11 MIC – Setup

This mode is for microphone setup and test only without using the PTT. It is a service mode and it is not designed for normal operation.

Each of the two microphone input channels can be configured individually, which enables different microphone types to be used.

A maximum of two microphones of same type may be connected to each microphone input channel (see chapter 6.6.1 Microphone-Connection).

The MIC – Setup is the last item of the Audio menu and can be accessed by pressing the AUD button nine times.



By pressing the DUAL button repeatedly L, R and AUTO can be selected (Left "L" in the example).

L: Left = Left microphone.

R: Right = Right microphone.

AUT: Auto mode.



Menus L and R:

By means of the turning knob the displayed microphone input channel amplifier gain (MIC-level 01 = low gain, 09 = high gain) can be selected individually. The microphone signal level is dynamically displayed with a bar and a numeric value.

The initial MIC-level should be 0,5; the engine should be running, use a headset or earphone and speak at a normal voice level to fine-tune the MIC-level. Whenever a new MIC level is selected, the dynamic bar indicator should then be at about 50%.

Special hint:

During MIC-Setup activation, the speaker state will be taken into account (SQU on/off), if the state is active an acoustic feet-back may be heard.

The range of the MIC-level for standard microphones is 1 to 9.

MIC levels 10 and 11 are special settings for low microphone levels like dynamic micro-phones often used in gliders.

- Level 10 is used for non-amplified Electret microphones with an 8 volt supply voltage.
- Level 11 is for dynamic microphones only.

For high gain selection (> 9) the use of side tone can lead to a feedback at transmission. In that case the side tone should be set to SIT=01.

The new values will be stored upon exiting the microphone setup menu. AUTO must be selected in order to activate the AUTO menu, else use L or R to activate the Left and & Right microphone menu.

Menu Auto

In the AUTO mode only the left microphone impedance is measured. When a dynamic microphone is recognized, the left channel is switch to 11, the right channel is unaffected. When returning to the standard configuration, the original L and R values are restored.



A simultaneous operation on Electret and Dynamic microphones is not possible (there is just one DC source for both ports). For dynamic mode this source must be turned off automatically.



The display of microphone type (lower right side) is done upon activation of the microphone menu. When an Electret microphone is recognized, the values used are the one that were saved upon leaving the menu.



The MIC submenu is terminated by pressing the AUD button.

Additional indications

Additional indications for test purposes:

- RxS : RF receiver input level (from Automatic Gain Control)
- Ext : External audio input voltage
- Mic : d (dynamic) or s (standard)

The microphone type is displayed when the microphone menu is entered.

This Symbol  appears on right side of STBY Frequency in AUTO-mode if the dynamic microphone has been recognized and activated after transmission. In that case the intercom voice triggering level VOX is set to 10 (switched off).

To reactivate the intercom after a microphone change, a short press of the PTT is required.

4.4.12 Menu lock

For school operation the menus area TXm to MIC-setup can be locked.

To lock or unlock the button combination AUD & FREQ has to be pressed simultaneously for > 2 seconds.

In lock condition there will be displayed an “L” at the right end of the third line.

To store those condition the setting of SQnn should be changed before turning off.

VOL	SQ	VOX	TXm	INT	EXT	DIM	CON	SIT	MIC
Available			Locked and not available						

Table 8: KRT2 Menu Lock

4.5 DUAL watch

Because the communication transceiver KRT2 contains only one receiver, DUAL watch is achieved by alternating between the Active and Standby frequencies.

The DUAL button activates and deactivates the dual watch function. Deactivation also can take place by pressing either the **FREQ** or **MEMORY** buttons.

The frequencies to be watched should be selected prior to the DUAL watch selection.

The frequencies to be used must be selected before using dual watch and the squelch level **SQ** must be set to 02 or more in order to eliminate noise. Scanning Frequencies is only possible when differentiating between radio noise and radio transmissions.

	<p>There must be radio noise suppression in order to recognize reception. The squelch level SQ must be set to 02 or higher.</p>
---	--

When DUAL watch is activated, "DUAL" is displayed on the lowest line. The pointer next to the DUAL display indicates the frequency on which there is reception.

The Active frequency always has priority and the receiver remains on the active frequency as long as there is reception on this frequency.

When there is no reception on both the Active frequency and the Standby frequency the receiver scans both frequencies 5 times per second.

When reception is detected on the Active frequency the reception on the standby frequency is interrupted until the end of the reception.

When a reception is detected on the Standby frequency the receiver stays on the Standby frequency, however it switches to the Active frequency every 2 seconds for a duration of 0.3 seconds. If a signal is detected on the active frequency the reception will be switch to that frequency.

The pointer next to the DUAL display indicates on which frequency there is reception.



Figure 4: KRT2 active & standby frequencies

Standby and Active frequencies can be exchanged when in the DUAL mode. The transmitter operates on the Active frequency only.

Summary:

- Select the Standby frequency to be monitored in addition to the active frequency.
- With the AUD button and turning knob set SQnn to 2 or higher.
- With the DUAL button activate the DUAL watch function.
- When there is no reception on both the Active frequency and the Standby frequency the receiver scans both frequencies.
- When scanning the Active frequency always has priority.
- Deactivate the DUAL watch function with the DUAL, FREQ or MEMORY buttons.

4.6 Transmitter Operation

The unit transmits on the active frequency (upper line) as long as a PTT (press to talk) switch is pressed.

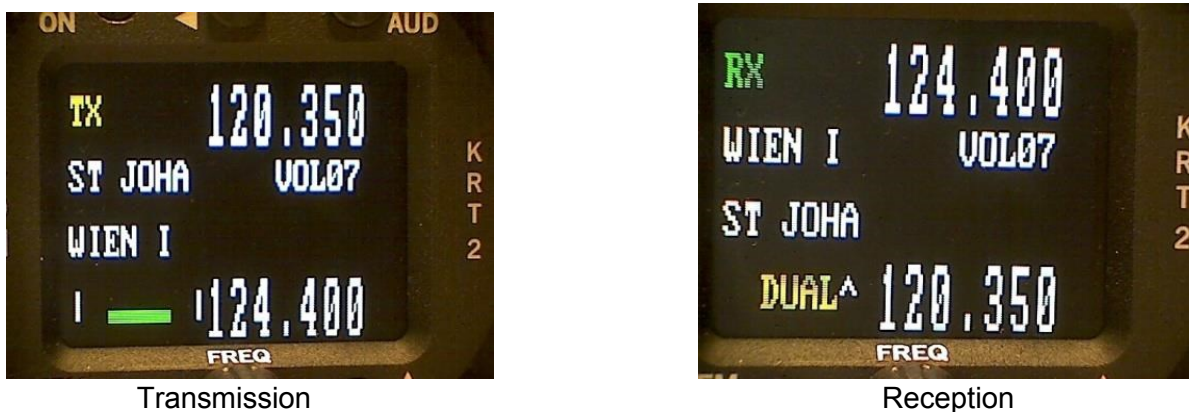

Figure 5: KRT2 TX & RX operations

“TX” indicates normal transmitter operation.
 “RX” indicates a receiver operation.

In the lower left corner of the display the carrier modulation is dynamically displayed. It corresponds to the side tone which is not available on gliders when no earphones are in use.

In order to avoid the blocking off of the frequency by unintentional long transmissions (stuck microphone) the transmitter is switched off after two minutes and the display changes from „TX“ to „Te“. To resume transmission the PPT switch first must be released and then be pressed again.

While transmitting the external audio input will be turned off automatically and the microphone input, selected during the pre-setting in the TXm-menu, will be selected.

The differential speaker output will be turned off to prevent an audio feedback to the microphone. For the same reason; the speaker is turned off when the intercom (VOX) is active.

The output for the headset will carry the side tone.



4.6.1 Two PTT configuration

There are two different PTT assigned for each of the left and right side microphones. This enables the deactivation of the unused one preventing additional noise and unintentional talking on transmission.

In case there is just one PTT and multiple headsets in use both the PTT-L and PTT-R must be tied together, see chapter "4.4.5 TXm – PTT Switch Selection".

4.6.2 Self-Test monitor

Software diagnostics operate continuously in the background in order to test the system.

The field for battery status & error (see Control Elements Overview) is used to display warnings and in case of hardware failure, different error reports will be displayed here.

The warnings are:

BAT Low battery voltage (becomes active < 10,5V)

At transmission

A-match Bad antenna match or defective antenna.

Also while transmitting the TX-flag (left top) will change to:

Te if transmission time has exceeded (> 2 minutes).

All other reports starting with Er_.... Indicating a major hardware failure and consequently the radio has to be returned to the factory.

4.6.3 Optical side tone

Especially when used in gliders, where headsets are generally not worn and thus no side tone is heard, it is very helpful to see if the microphone is operating properly.

At left lower side, there is a modulation indicator that depicts the voice level. When there is no modulation it becomes a small dot approximately in the centre.

Also if it lays far off centre, it indicates that there is bad antenna matching.



4.7 Resetting to factory settings

Returning to the factory settings can only be initiated during power-up.

To do this, during power-up the MEM and DUAL buttons must be pressed simultaneously and the display will show "SET DEFAULTS". When the buttons are released the resetting to the factory settings takes place. When resetting is completed "DONE" is displayed.

4.8 SET UP - Menu

During power-up the MEM button must be pressed.

The message "protect mode" is displayed, just wait until it changes.

There are two functions available within the Set-up menu:

- ERASE – Erasing of the favorites (frequency and identifier)
- Channel Spacing – 25kHz / 8,33kHz

Programming of the Set-up is done with the lower 3 buttons next to the symbols (Exit, S, E). Their function is described on the display.

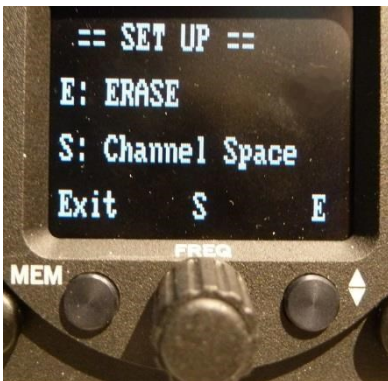

To exit the SET-UP menu, use the MEM button. The unit remains powered and the normal operating mode is resumed.

4.8.1 ERASE – erasing of favourites list

When in the SET UP – Menu select the “ERASE” sub-menu with the buttons next to the symbols (Exit, Y).

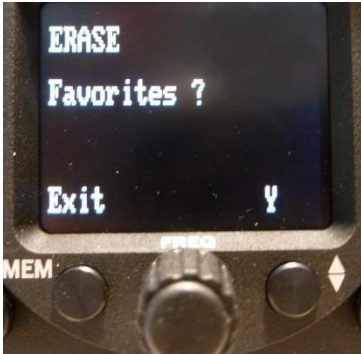

Erasing the favourites (frequency and identifier) starts after the  button has been pressed again. This procedure may last a few minutes during which time the message “ERASING” is displayed. All INFO frequencies and identifiers that were stored on delivery are lost and all favourite index positions (01 to 99) are available to the user.

4.8.2 Channel spacing

When in the SET UP – Menu pressing the FREQ (S) button will change the KRT2 into the Channel Space submenu.



The desired channel spacing then can be selected and the (X) then indicates the actual channel spacing.



5. Remote Control

Tandem-seat airplanes can be equipped with the KRT2RC Remote Control Unit. The remote control unit is connected to RS232 serial interface and enables selection of the most common settings like frequency, volume, squelch, VOX, display contrast and brightness. In addition the unit has an independent memory for the favourites (frequency and identifier).

Transmission error messages are displayed in the error window in the third line:

- R_Time = Time-out transmission error
- R_ChkS = Checksum error
- R_Cmd = Unknown command
- R_Char = Data error
- R_Freq = Wrong Frequency

The error message disappears when a valid command or a new frequency has been input, or after 5 seconds.

Remote control unit errors do not interfere with the KRT2 transceiver operation.

Data transmission between the transceiver KRT2 and the remote control unit (KRT2-RC) is checked once a minute. An “r” in the upper right corner is displayed when there is no malfunction.

The KRT2-RC can also operate the KRT2 in a fully stand-alone mode such and allow the KRT2 to be installed anywhere in the aircraft, and be operated remotely by the KRT2C. This feature will be useful in tandem aircraft, or aircrafts with very little space behind the instrument panel.

ACL

K-DUO

Operation :

Switch ON = flash active

Switch OFF = flash not active

Emergency operation :

In the event of a malfunction or failure, the system must be switched off immediately and must stay off for the remaining flight time. Never switch on the system again inflight, after or while persisting errors.



Caution, high intensity optical radiation!



Handling on ground: do not look directly into the light!



Avoid direct contact with water!



OPERATING MANUAL FLARM COLLISION WARNING UNIT

Status

Software Version 5.00 (March 01, 2011)

This is a translation of the German manual.

© 2003-2011 FLARM Technology GmbH
Baar-Switzerland
www.flarm.com
info@flarm.com

1. Welcome to the FLARM user community

Thank you for purchasing FLARM, a modern low-cost collision-warning unit for sailplanes and light aircraft. The main task for FLARM is to support the pilot, while he scans the airspace ahead with his own eyes. FLARM is simple to use and does not distract the pilot from the main business in hand.

 Sport flying is an activity that is associated with considerable risks for crew, passengers, third parties and other objects. **In order to make full and safe use of FLARM, it is absolutely essential to be fully aware of the risks, operating conditions, restrictions and limitations associated with the use of FLARM, ensure a proper installation and do regular software updates. This includes familiarity with and observance of this Operating Manual and the Installation Manual.** Additional configuration information can be found in the 'Data Port Specifications' document, e.g. how to suppress additional data at the serial port what might be required in international championships.

We welcome user feedback and reports, suggestions for improvements, and pictures that will help us make further improvements to FLARM. Feedback reports should give a detailed description of the situation, quoting the Hardware and Software versions used, plus the flight data records in IGC format with short time recording intervals.

The latest version of this handbook and other related documents can be found at the Website www.flarm.com. This Website also has answers to Frequently Asked Questions.

This Website also carries announcements when new software versions or functions become available. If you enter your name on the mailing list, you will automatically receive notification of changes as and when they happen: https://lists.flarm.com/mailman/listinfo/user-list_flarm.com

To use existing devices in March 2011 or later, it is required to update the software to version 4.00 or higher. Use the free PC installation software available at www.flarm.com. You need a PC with Windows 98 / ME / 2000 / XP with a serial port or a suited USB-serial converter plus a data-power cable like the one used for most IGC flight recorders. This cable connects the PC to FLARM and supplies FLARM with power. Ensure you have configured the correct PC COM-port, only use the Power/Data-port on FLARM (not the Extension-port) and know the printed device serial number. After completion of the software update, use the same PC software to load the most recent obstacle file to FLARM; this file is available on www.flarm.com as well. Then use the PC software to configure the flight recording functionality accordingly. In case of questions, contact your FLARM dealer.

 Software-Versions 5.x must not be used after **March 01, 2015**. Before this date, you must update the device in order to use it in the air.

2. How it works

FLARM receives position and movement information from an internal 16 channel GPS receiver with an external antenna. A pressure sensor¹ further enhances the accuracy of position measurements. The predicted flight path is calculated by FLARM and the information - including a unique identifier - transmitted by radio as low-power digital burst signals at one-second intervals. Provided they are within receiving range, the signals are almost at the same time received by further aircraft also equipped with FLARM. The incoming signal is compared with the flight path predicted by calculation for the second aircraft. At the same time, FLARM compares the predicted flight path with known data on obstacles, including electric power lines, radio masts and cable cars.

If FLARM determines the risk of dangerous proximity to one or more aircraft or obstacles, the unit gives the pilot warning of the greatest danger at that moment. The warning is given by a whistle sound (beep) and bright light emitting diodes (LED). The display also gives indication of the threat level, plus the horizontal and vertical¹ bearing to the threat. During circling flight different methods of calculation are employed to those used during straight flight.

The GPS and collision information received from other aircraft can also be made available for third party equipment (e.g. external display, speech synthesizer, PDA) via a serial data output. Such equipment is available from a number of manufacturers.

¹ Requires Hardware Version 2 or higher. However, the vertical bearing on the serial data output is also available to third-party equipment on Hardware Version 1.

The operating range is very dependent upon the antenna installation in the aircraft. The normal range is about 2 km. In individual cases the range may be up to 5 km, which can be valuable for fast sailplanes with a speed of up to 250 kt, providing the pilots in both aircraft with a warning enabling visual identification and reaction to the potential hazard. The effective range can easily be verified with an online tool². Warnings are given in order of the time remaining before a potential collision, not the geometrical distance. The first warning level for another aircraft or an obstacle is delivered when less than 18 seconds remain to the possible collision; the second warning level is delivered when less than 13 seconds remains; the third level when less than 8 seconds remains.

The warnings continue as long as FLARM calculates a threat of collision. The warning level may decline or be cancelled, depending upon the prediction. The warnings are selective; they are only issued if the calculation reveals a high probability of collision in the near future. The alarm sensitivity can be configured with the PC.

In addition, FLARM operates as an IGC-file compatible flight recorder including the G-record. Flight logs can be read out either via the SD-card or via the data port and a suitable cable. The SD card does not need to be carried on during the flight. FLARM is optionally also available as diamond-level IGC-*approved* Flight Recorder, optionally with Engine Noise Level sensor (ENL).

With the standard April 2008 obstacle databank there is memory for more than 50 hrs of flight recording at a 4s interval. Use the free PC-software to download flights to your PC and to properly configure your device for flight recording. Flight recording automatically starts when the aircraft is moving and ends when the unit is switched off. Switching off the device during the flight for a longer period results in separate flight record files. Allow at least 2 minutes (if the interval is 4s, our recommended value) after landing before you switch off the device else you lose the last part of the flight. Allow more time after landing if the interval is higher. When the memory is full, the oldest data is overwritten. Always download your flight data before you update the obstacle databank or the software.

FLARM applies for the radio communication between the units a proprietary patent- and copyright-protected protocol. It is not public, but FLARM Technology offers a license contract where it is accessible in the form of a compatible core design ready for integration into 3rd party systems. These systems are officially declared as FLARM-compatible. Any non-licensed use, dissemination, copying, implementation or reverse engineering of the FLARM radio communication protocol, the FLARM hardware and software or parts of it is forbidden by law and will be prosecuted. FLARM is a registered trademark and can not be used without license.



3. General Advice on Operation

This Manual must be carried on board the aircraft. When permanently installed in an aircraft, the 'AFM Supplement' must also be carried in the aircraft.

In flight the pilot must have direct sight of and immediate access to a switch or circuit breaker that disconnects FLARM from the aircraft electrical power supply, without affecting other essential aircraft systems. This might be necessary if the pilot suspects that FLARM may be interfering with another on-board system, the suspected presence of smoke, the smell of smoke, or flying in a country where the use of FLARM is not permitted.

FLARM must not be operated at night or with night vision systems.

FLARM will not operate without adequate GPS signal strength. Correct antenna installation has a great effect on the transmission/receiving range.

FLARM is not able to measure its own RF-receiver sensitivity. When the pilot detects that other aircraft are received only when very close or not at all and when the RF-antenna's positioning is clearly not the cause of it, the device must be checked by the manufacturer.

² www.flarm.com/support/analyze

Installation and operation must be on the basis of non-interference with and no hazard to the existing suite of other certified equipment necessary for safe flying operation, or installed to comply with official requirements. Installation and operation must comply with official regulations and requirements. It is recommended that the FLARM, GPS and radio antennae are all installed as far away as practicable - but at least 25 cm from - susceptible aircraft systems such as GPS antennae and the magnetic compass.



The unit must be protected from solid particles or liquids, should not be exposed in use to temperatures below -10°C or above +60 °C , or stored at temperatures -20°C or above +70 °C, because this may cause irreparable damage. On the ground, the unit should be protected from exposure to long periods of direct sunlight, because it is likely to be overheated. Also avoid static discharges to the radio antenna.



Details on correct installation will be found in the Installation Manual.

4. Operating Modes

FLARM operates in two modes, *Nearest* and *Collision*. The change from one mode to the other is effected by a two-second push on a button followed by a brief visual confirmation from the unit. After the change has been signalled, the current mode selected is not displayed. When switched on, the unit is in *Nearest* mode.

 The warnings given are identical in both modes, and generally relate to an immediate threat to which the pilot should make an immediate and appropriate reaction. The assumption has been made that following a warning it will take up to 12.5 seconds from the time that the other aircraft is seen, until a change in flight path has removed the threat³.

When operating in the *Nearest* mode, the unit also reports the presence of other aircraft operating in the vicinity, even though calculations indicate that they do not represent a threat. The information displayed is limited to a configurable radius (default is three kilometres) and a vertical separation of 500 m. When no aircraft was displayed so far but one is received now, this is signalled with a click-sound. Only one single aircraft is indicated, with Hardware Version 3 or later in green. The optical signal is static (no flashing); the threat intensity is not indicated and there is no sound warning. As soon as FLARM detects the risk of a collision it automatically switches to *Collision* mode, followed by automatic reversion to *Nearest*. The choice of mode is presented, such that immediately after pressing the key, the display presents a diverging pattern (Hardware Version 1 and 2:  ; version 3: ).

When operating in the *Warning* mode a red LED lights up only if the calculation predicts a threat. Warnings are always shown by flashing LEDs, the threat level being shown by the number of LEDs illuminated, by the frequency of flashes, and the simultaneous sound signal (beep). Selection of this mode is indicated by a upwards converging pattern (Hardware Version 1 and 2:  ; Version 3: ) immediately after pressing the selector key.

In both modes the pilot can **suppress the display and the acoustic warning**: after a double push FLARM will suppress all visual and acoustic signals relating to traffic, obstacles or other threats. The act of selecting suppression is followed by a descending tone. A further double-push reinstates the *Collision* mode at once and is followed by a rising tone. While warnings are suppressed, FLARM nevertheless continues to transmit signals for reception by other aircraft.

³ These times were published in 1983 FAA Advisory Circular 90-48-C and were based on military data. They relate to fast jet pilots with no on-board warning systems for other traffic and hazards. The assumption was made that only one aircraft takes avoiding action. Of the 12.5 seconds, five seconds were to recognise the threat of collision and four seconds were required to decide upon avoiding action. No information is available as to whether these times are applicable to light aircraft, sailplanes or helicopters, when using a warning system.

5. Front Panel

The dark grey front panel of Hardware Versions 1 and 2 has a push-button, four green Status-LEDs, ten red collision warning LEDs and four red LEDs for vertical¹ position indication.

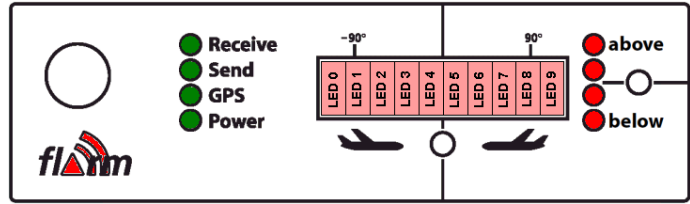

Push-button 4 green LED (Status) 10 red LED (horizontal) 4 red LED (vertical¹)

The front panel of Hardware Version 3 has a push-button, four green Status-LED, twelve bicolour LED for horizontal and four bicolour LED for vertical position indication. Depending on the threat caused by other aircraft or obstacles the LED show up red or green. Also included is a microSD-reader which can be used for updates, downloads and configurations. microSD cards are not included, but widely available in electronic and mobile phone shops.

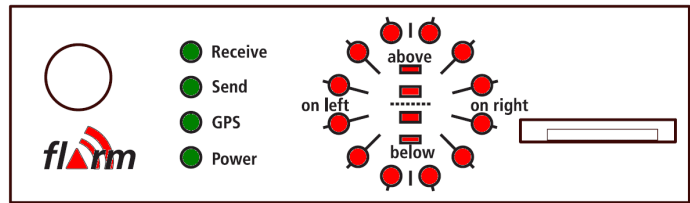

Push-button 4 green LED (Status) 12 LED (horizontal) 4 LED (vertical) all bicolour microSD reader

6. Start-Up

FLARM is always switched on if the unit is connected to an adequate power supply.

Immediately after it has been switched on there follows a one-second long beep while a start-up pattern might be shown on the LED, followed by a binary presentation of the Hardware-Version installed during the system self-test. The self-test mode lasts around 8 seconds, depending upon the size of the obstacle data bank.

0x01 Hardware Version 1 (only red)



0x02 Hardware Version 2 (only red)



This is followed by another one-second beep, followed by a binary presentation of the Software-Version:

- Hardware Versions 1 and 2: LED0 to LED3 represent the major versions, LED4 to LED9 the minor versions. Everything is shown in red.

If the Software Version is not indicated and the beep sound is not emitted, the unit is not ready for operation.

Software Version 1.xx (operational only to April 2005)

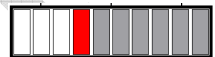

Software Version 2.xx (operational only to Feb 2006)



Software Version 3.xx (operational only to March 2008)

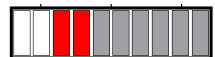

Software Version 4.xx (operational only to Feb 2011)



Software Version 5.xx (till March 01, 2015)



Then FLARM shifts to normal operation and waits until it has acquired an adequate GPS position fix. When switching on, this procedure can take *several minutes*. Without a proper GPS position fix, the unit is not ready for operation. Before departure the pilot must ensure that at least the Power-, GPS- and Send-LED are all continuously on. This state must be preserved during the whole flight to ensure correct operation.

7. Fault Finding

If a fault should occur during start-up self-test or subsequent operation, then all four green status LEDs will flash in unison for 30 seconds, while the red collision LEDs will give a binary indication of the most serious fault. The fault display can be stopped before 30 seconds has elapsed by pushing the button.

For safety reasons FLARM will not start up if there is a fault. FLARM may not be used if a fault has been reported or indicated. Limited operation is possible if there is an indication of a problem with the obstacle data bank or data recorder.



0x11	Fault: Software out of date (needs GPS reception)	No operation	
0x12	Fault: Software integrity violation (only IGC-units on F5)	No operation	
0x21	Fault: Low Voltage	No operation	
0x31	Fault: Internal GPS communication	No operation	
0x32	Fault: Faulty GPS configuration	No operation	
0x41	Fault: Internal radio communication	No operation	
0x51	Fault: General internal communication	No operation	
0x61	Fault: Flash memory	No operation	
0x71	Fault: Pressure sensor	No operation	
0xF1	Fault: Other fault	No operation	
0x81	Indication: No obstacle data bank	Operation possible	
0x91	Indication: Flight recording not possible	Operation possible	
0x93	Indication: ENL recording not possible (only IGC-units on F5)	Operation possible	
0xA1	Indication: Error with SD-card configuration file	Operation possible	

The communications faults itemised above indicate if internal modules within FLARM are not communicating correctly with each other. For reasons associated with the system, reduced radio range cannot be detected by a single unit alone.



Software-Versions 5.x must not be used after March 01, 2015. Before this date, you must update the device in order to use it in the air. An update with the same functionality can be downloaded free of charge. Users will be able to load the software with the aid of a suitable power supply/data cable (not supplied). This operation requires the user to have the unit Serial Number to hand. Software validity has to be time-limited to ensure that all FLARM units are mutually compatible and that updates include the latest obstacle data.

8. Status-Display

The green Status Display LEDs operate as follows; normal operating mode is underlined:

- **Receive:** Lights up when a signal is detected from another aircraft less than the configured range (default is 3 km) away, with a height separation of less than 500 m; otherwise the LED is dark. If the warning is temporarily suppressed (see below) but signals are still received from other aircraft, then the LED flashes.
- **Send:** Lights constantly during operation and indicates that the on-board FLARM is transmitting. Transmission requires GPS reception.
- **GPS:** Lights constantly during operation (with very brief interruptions once per second). If the LED is constantly dark and flashes briefly once per second, then there is no GPS reception. When switching on this condition can take several minutes.
- **Power:** Lights constantly during operation. If the LED flashes, then the power supply has dropped below 8 V. FLARM will not operate below 8 V DC.

The 'Receive' and 'Send' LEDs give no indication of FLARM's transceiver range.

9. Push Button⁴

The push button can be used to select the following functions:

- **Brief Push** (<0.8 s) changes the volume from *<loud>* to *<medium>* to *<quiet>* to *<silent>* (and *<loud>* again). A short sound is emitted at the new volume selected. The default setting is *<loud>*.
- **Longer Push** (2 s) changes mode between *<Nearest>* and *<Collision>* when airborne. Visual confirmation. Default setting *<Nearest>*.
- **Longer Push (5 - 8 s, only on the ground)** activates the receiver self-test: Two seconds after the button is released, FLARM will show how many other FLARM are received with reduced sensitivity (50% of the normal range). It will then emit a long beep and light one vertical LED for every 10 and a short beep and one horizontal LED for every single received aircraft (e.g. 14 received FLARM is: "beeeeep bep bep bep bep", with one vertical and 4 horizontal LED's). After the self-test, FLARM switches back to normal operations. Note that for other units to be displayed these must be running.
- **Double Push** suppresses optical and acoustic warnings for five minutes. Suppression is followed by declining melody, normal setting followed by a rising melody. A double push terminates the suppressed operation at once.
- **Long Push** (>8 s): Re-boot. This procedure is recommended if a fault is apparent. No confirmatory sound signal.
- **Very long push** (>20 s) brings FLARM back to the factory settings. The very long push deletes all configurations that have been loaded by the user. No confirmatory sound signal.

⁴ Activate the external display update by pushing the button four times in rapid succession. For details see the Installation Manual.

10. Aircraft Anti-Collision Warnings

An illuminated red LED indicates the approximate bearing to an aircraft currently posing the biggest threat of collision. The bearing is *relative to the track*. This indication is inaccurate if there is a strong wind, if the aircraft is in a sideways yaw, or if ground speed is very low (e.g. when a helicopter is in the hover). The display is refreshed every second.

The unit emits an audio warning (beep) tone at the same time as the flashing red optical warning. The time between the warning and possible collision is brief, just a few seconds. Warnings of fixed obstacles are given slightly earlier.

Horizontal bearing indicated on Hardware Versions 1 and 2

Each red LED is allocated to a sector of sky around the aircraft horizontal plane in a side view. The aircraft centreline is indicated by a white line above and below the mid point (between LED4 and LED5). A short white line is located above LED1 and LED8, marking 90° left and right.

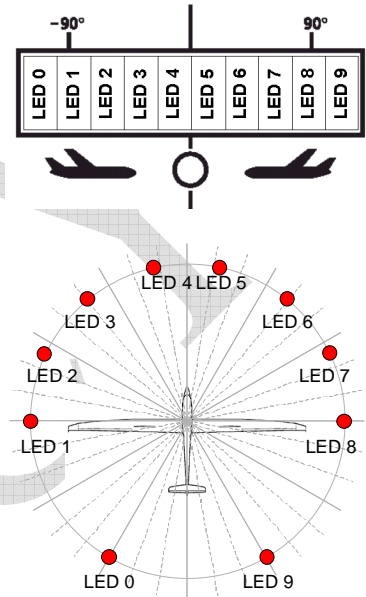

- LED 0 ~210° quadrant rear left
- LED 1 270° hard left 9 o'clock
- LED 2 296° left 10 o'clock
- LED 3 321° left 10-11 o'clock
- LED 4 347° front left 11-12 o'clock
- LED 5 13° front right 12-1 o'clock
- LED 6 39° right 1-2 o'clock
- LED 7 64° right 2 o'clock
- LED 8 90° hard right 3 o'clock
- LED 9 ~150° quadrant rear right

Horizontal bearing indicated on Hardware Version 3 and later

The twelve bicolour LED show a compass rose, i.e. the birds view on the traffic situation. 'Top' is track-up according the own aircraft. Each LED covers an equal-sized horizontal sector of 30°.

Danger from the front or side

If the threat of collision with another aircraft is from the front or side, but not from the rear, then the threat level will be flagged up by the display. If the threat is moderate (less than 18 seconds to possible collision), a single LED lights up; in the case of a medium threat (less than 13 seconds) then two diodes light up; if the threat is imminent (less than 8 seconds) three LEDs. The threat is at the centre of the illuminated block. The flash and beep frequency increases with the threat.

Moderate threat from ca. 3 o'clock
(less than 18 seconds to calculated collision)

Slow flash at 2Hz



Moderate threat from 1 to 2 o'clock
(less than 18 seconds)

Slow flash at 2Hz

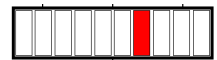
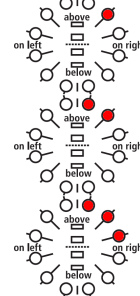

Medium threat from 1 o'clock
(less than 13 seconds)

Medium flash at 4Hz

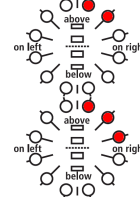

Immediate threat from 1 to 2 o'clock
(less than 8 seconds)

Rapid flash at 6Hz

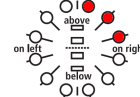

Danger from the rear

If the threat is from behind, then the threat level on Hardware Version 1 and 2 is given only by the frequency of LED flashes, not the number of LEDs activated.

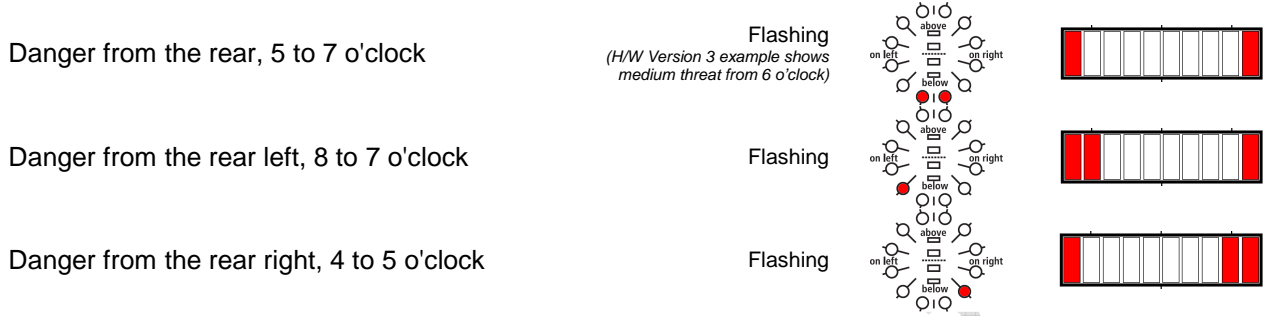

Vertical indication

The vertical bearing is indicated by a vertical¹ line of four red LEDs and show the bearing relative to a horizontal plane. This is independent of the aircraft's climb angle. The uppermost or lowest LEDs illuminate when the bearing exceeds 14°. The LED flash frequency is identical and synchronous with that of the horizontal display.

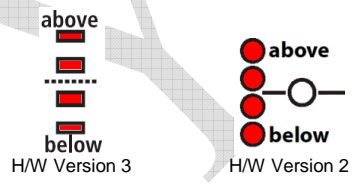

Traffic indication (only in Nearest-mode)

In Nearest-mode the closest aircraft is shown as long as no warning is necessary. Traffic indications don't flash, there is no sound and the distance is not shown. Hardware Version 3 and higher show traffic indications in green.

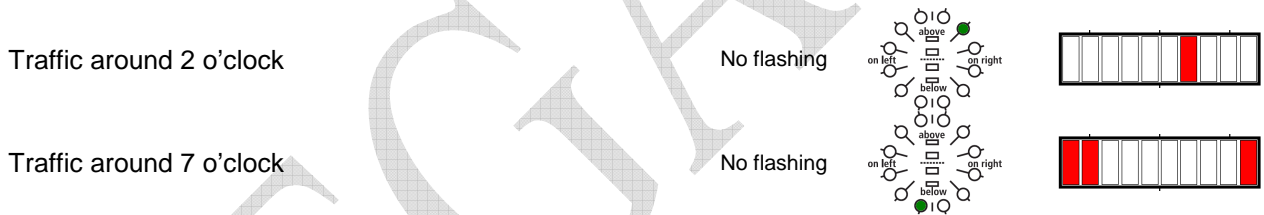

11. Obstacle Warnings

The standard obstacle data bank (as of Feb 2011) has about 35,000 coordinates locating about 11,000 Alpine obstacles⁵. This data bank is loaded by FLARM at manufacture; subsequently the user may upload but not alter up-dated information via a PC. Special data banks, corrections and amendments can be reported to us.

The FLARM display flashes when there is warning of obstacles. The warning always relates to obstacles straight in-line with the current flight heading. In other words there is no horizontal or vertical bearing given to the obstacle. The threat level depends upon the time remaining to impact; the flash and beep frequency increases with reducing distance from the obstacle. The display is refreshed every second.

A warning is given if an aircraft flies under a cable or power line.

An acoustic warning (beep) is given at the same time as the flashing fixed obstacle warning. The time between warning and possible collision is brief, just a few seconds. However, warnings are given of fixed obstacles earlier than those for other aircraft.

Hardware Versions 1 and 2 show obstacles as follows:

- Moderate threat
(less than 18 seconds to calculated collision)
- Medium threat
(less than 13 seconds)
- Immediate threat
(less than 8 seconds)

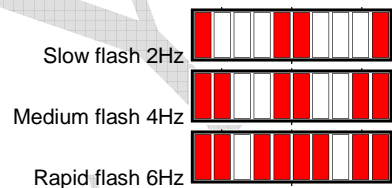

Hardware Versions 3 and later show obstacles as follows:

A toggling pair of two LED's is shown, with the toggle frequency depending on the threat.

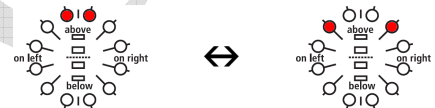

⁵ For details on the data sources and status, consult the 'Obstacle Data Format Specifications' manual.

Neither FLARM Technology nor these organisations accept any responsibility for the accuracy, completeness or up-to-date status of the data or any direct or indirect damage resulting from using such data. Official data sources only collect data which have been reported by those who own, construct or operate constructions which represent an obstacle, and do not check these reports.

12. Operating Limitations



FLARM is designed and built as a non-essential 'situation awareness only' unit to only support the pilot, and cannot always provide reliable warnings. In particular, FLARM does not give any guidance on avoiding action. Under no circumstances should a pilot or crewmember adopt different tactics or deviate from the normal principles of safe airmanship. Even with FLARM installed, you remain responsible for flying the aircraft and ensure the safety of passengers and other traffic. The use of FLARM is solely at the discretion of the commander and his delegated crew member. Operation must be preceded by thorough familiarisation by the commander or his delegated crew member with the Operating Manual.

FLARM will only give warnings of other aircraft that are likewise equipped with a compatible unit. FLARM does *not* communicate with Mode A/C/S transponders and is not detected by ACAS/TCAS/TPAS or Air Traffic Control. Likewise FLARM does not communicate with FIS-B, TIS-B or ADS-B.

Compatible FLARM units must be within range in order to provide a warning. The range is very much determined by the type, installation and position of the radio antennae, plus the relative positions of the two aircraft. Under *optimum* conditions the internal antennae can give a head-on range of up to 5 km; normally, range is about 2 km, which is adequate for light aircraft and sailplanes. The radio signals can only be received by *line of sight*. There is no FLARM signal between two aircraft on opposite sides of the same mountain.

FLARM has to know its *current* position in order to operate. For this reason, FLARM will only operate in the presence of good quality three-dimensional GPS reception. GPS reception is greatly influenced by the installation and position of the antenna, and aircraft attitude; furthermore, it requires that the US-american GPS-system is fully operational. This is particularly true during turns, when flying close to mountain slopes and in areas known for poor reception. If the installation is poor the GPS signal quality may be reduced. In particular, there can be rapid degradation of height calculations. FLARM resumes operation as soon as the GPS reception quality is adequate.

Movements calculated by the GPS relate to a fixed system of *terrestrial* coordinates. In strong wind there may be a substantial difference between aircraft heading and track, leading to a distortion of the threat bearing. If the wind speed is one third of True Airspeed (TAS) and the yaw-free aircraft Heading is 90° out of wind, then the threat indication displayed has an error of about 18°. If the wind is very strong, the Track can deviate up to 180° from Heading. Under such circumstances and when circling, the calculation and warnings given are unusable.

When close up, when two aircraft are at the same or similar height, or GPS reception is poor, the vertical bearing indication is imprecise and fluctuates.

FLARM calculates the predicted flight path of the aircraft to which it is fitted for less than the next 20 seconds. This prediction is based on immediate past data, current position- and movement data, plus a movement prediction model that is *optimised for the respective user*. This forecast is associated with a number of uncertainties that increase with an extension of the forecast time. There is no guarantee that an aircraft will actually follow the predicted flight path. For this reason, the warning issued will not be accurate in all cases. In sport flying flight path predictions of more than 30 seconds are *unusable*. This is particularly true for sailplanes and hang gliders. For this reason, the radio range is generally adequate.

Warnings are given at very short notice, i.e. the warning is given within a time frame of from a few seconds to 18 seconds, depending upon the closest predicted proximity, as calculated. The threat intensity (pitch of the warning tone, LED block width, flash interval) flags up the threat (collision time point), but not the geometric distance. FLARM only issues a warning if the calculation forecasts a *considerable* threat. For this reason, it is usual - depending upon the mode selected - that no warning is given about the presence of other aircraft, in spite of the fact that signals have been correctly received.

When a number of moving threats or fixed objects are within range, then FLARM gives warning only of the most dangerous in accordance with the threat calculation algorithm. The pilot is unable to confirm receipt of this warning, nor is he able to call for presentation of further threats. In spite of the warning issued for one other aircraft or fixed objects, it is quite possible that there are several further aircraft or fixed objects that represent a greater threat than that which has been signalled. When the unit simultaneously detects a threat from moving and fixed obstacles, then the warning issued relates to the earliest likely collision.

FLARM indicates the rough position of the aircraft or obstacle that currently represents the biggest threat, in accordance with the algorithmic calculation; FLARM Hardware Version 2 (and onwards) also displays a vertical bearing. In the case of fixed obstacles, the unit does not signal a bearing. FLARM does not indicate where the closest proximity may occur, nor does it signal avoiding action. Whether and how avoiding action is taken is solely a matter for the pilot, who must base his decision on his own observation of the airspace. In taking his decision, he must comply with the Rules of The Air and ensure that no additional hazard is caused by his action. Depending upon the phase of the flight, FLARM uses different forecasting methods, movement models and warning calculations, to provide the pilot with the best possible support without causing a distraction. For example, when a sailplane is circling, the system sensitivity is reduced. These models and processes are optimised, but are nevertheless a compromise. As seen by the pilot these models are the source of 'false alarms'; i.e. FLARM would give warnings of 'threats' that would not subjectively be regarded as a real danger. It is quite possible that FLARM will not give warning of the highest threat, or will give any warning at all.

Obstacle warnings (e.g. cables, antenna masts, cable cars, avalanche dynamite wires, power lines) are dependent on the information having been stored *correctly* in the internal data bank. The unit cannot give warning of any fixed object that has either been incorrectly stored, or not stored at all. No data bank is complete, up-to-date and correct. Obstacle information stored has usually been simplified; for example, FLARM assumes that a power wire is slung absolutely straight between two fixed points with no sag. Likewise, data for power lines and cable cars does not include all intermediate masts. In addition, FLARM data does not include terrain data and no such warnings are possible.

FLARM radio communications take place in a license-free band in which there is general freedom to transmit and receive. This means that the band is also available to a number of other uncoordinated users. FLARM has no exclusive right to the use of this band and there is no guarantee that FLARM will not be subject to interference by third parties.

There are national differences in frequency allocation and operating conditions between countries. The aircraft commander and user are solely responsible for ensuring that their use of FLARM conforms with local regulations. No radio licence is required for FLARM in Switzerland, Germany and France.

The radio transmission protocol employed places *no limit* on the number of units that may be operated within a given range. However, an increasing number of units within range is associated with a reduction in the probability that a single coded signal will be received ('graceful degradation'). The probability is small that subsequent signals will not be received from the same transmitter. FLARM is designed to receive and process signals from up to 50 aircraft within range. A high number of FLARM units within range has no effect on range.

The transmitter has ***no effect*** on what the receiver in the other aircraft does with the data. It is possible that this data may be captured and stored by other aircraft, or by ground stations, or used for other purposes. This opens up a range of possibilities, some of which may be in the pilot's own interest, (e.g. automated generation of an sailplane launch logging system, aircraft tracking, last position recovery), while others may not be (e.g. detecting tailing of other aircraft, airspace infringements, failure to take avoiding action prior to a collision). When FLARM makes a transmission, the signal also bears a unique identification code that can trace to the pilot or aircraft registration. The user can - even though this is not recommended - configure the unit so that identification is generated randomly and alters at one-minute intervals, making a back-trace difficult.

Operation of FLARM is limited to non-commercial day VFR flights. FLARM may not be used for navigational purposes or aerobatics.

At present FLARM has not been certified or tested in line with the usual aviation procedures (e.g. DO-160E). The FLARM software development is *roughly* in-line with Level E of DO-178B; i.e. a partial or total failure of FLARM will have no effect upon the safe operation of the aircraft, nor does it increase crew workload.

Operation of FLARM is forbidden in the USA or Canada or in aircraft registered in the USA or Canada.

The association FLARM Technology, FLARM Technology GmbH, its associates, owners, staff, management, development team, suppliers, manufacturers and data suppliers accept no responsibility for any damage or claims that may arise from use of FLARM.

USER MANUAL



S8x S10x

Digital speed-to-fly variometer, final glide calculator and navigational system with simple moving map

Version 9.0



1	Important Notices	8
1.1	Limited Warranty	8
2	Packing Lists	9
2.1	S80 (80mm) Variometer Unit	10
2.2	S8 (57mm) Variometer Unit	11
2.3	S10 (57mm) Variometer Unit	12
2.4	S100 (80mm) Variometer Unit	13
2.5	S10D and S8D Repeater Unit	14
2.6	S100D and 80D Repeater Unit	15
3	Basics	16
3.1	LXNAV S8x/S10x at a Glance	16
3.2	LXNAV S8x/S10x Features	17
3.2.1	Interfaces	17
3.2.2	Options	17
3.2.3	S8/S80 Club	17
3.2.4	Technical Data	18
3.2.4.1	Power Consumption	18
3.2.4.2	Size and Weight	18
3.2.4.3	Audio output power	18
3.2.4.4	Environmental limitations	18
4	System Description	19
4.1	Push Button – Rotary Switches	19
4.1.1	Power Button	19
4.2	Rotary Switches	19
4.3	Buttons (Three)	20
4.4	Switching on the Unit	20
4.5	User Input	21
4.5.1	Text Edit Control	21
4.5.2	“Spin” Control	22
4.5.3	Selection Control	22
4.5.4	Checkbox and Checkbox List	22
4.5.5	Slider Selector	23
4.6	Switching Off	23
5	Operating Modes	24
5.1	Quick Access Menus	25
5.1.1	MC/BAL	25
5.1.2	Reset G	25
5.1.3	Layout	25
5.1.3.1	Layout in the Numerical Page	26
5.1.3.2	Layout in the Graphical Page	27
5.1.4	Select / Select Near (Only in WPT mode)	29
5.1.5	WPT Elevation	29
5.1.6	Edit Target	29
5.1.7	FLARM Traffic	29
5.1.8	Event	29
5.1.9	Night	29
5.1.10	Edit Task (Only in Task Mode)	30
5.1.11	Start Task (only in Task Mode)	31
5.1.12	Restart Task (only in Task Mode)	31
5.1.13	Next Waypoint (only in Task Mode)	31
5.1.14	Send WPT	31
5.1.15	Load/Save	32

5.1.16	Export	32
5.1.17	Wind	32
5.2	Info Mode	33
5.2.1	Quick Access Menu	33
5.3	FLARM Mode	34
5.3.1	Quick Access Menu	35
5.3.1.1	Edit Target	35
5.3.1.2	FLARM Traffic	35
5.3.2	FLARM Warnings	35
5.4	Thermal Assistant Mode	36
5.4.1	Quick Access Menu	36
5.5	Waypoint Mode	37
5.5.1	Quick Access Menu	37
5.5.2	Numerical page	38
5.5.3	Wind Page	39
5.5.4	AHRS Page	40
5.5.5	Quick Access Menu	40
5.6	Task Mode	41
5.6.1	Numerical Page	41
5.6.2	Wind Page	41
5.6.3	AHRS Page	42
5.6.4	Quick Access Menu	42
5.6.4.1	Editing navboxes	43
5.7	Setup Mode	44
5.7.1	QNH & RES	45
5.7.1.1	QNH	45
5.7.1.2	Safety Altitude	45
5.7.2	Flight Recorder 	45
5.7.2.1	Recording Interval	45
5.7.2.2	Auto Finish	46
5.7.2.3	Finish Before OFF	46
5.7.2.4	Logger Always ON	46
5.7.2.5	Pilot	46
5.7.2.6	Co-Pilot	46
5.7.2.7	Competition Number	46
5.7.2.8	Registration Number	46
5.7.3	Vario Parameters	47
5.7.3.1	Vario Needle Filter	47
5.7.3.2	Vario Sound Filter	47
5.7.3.3	Netto Filter	47
5.7.3.4	Relative Filter	47
5.7.3.5	SC Filter	47
5.7.3.6	Smart Filter	47
5.7.3.7	Needle Range	48
5.7.3.8	Auto SC (Speed Command)	48
5.7.3.9	TE Compensation	48
5.7.3.10	Vario Average Time	49
5.7.3.11	Integrator Reset	49
5.7.3.12	Temperature Offset	49
5.7.3.13	Airspeed Offset	49
5.7.3.14	HAWK enable/disable 	50

5.7.3.15	HAWK wind variance	50
5.7.3.16	HAWK Horizontal wind average	50
5.7.3.17	HAWK Vertical wind average	50
5.7.4	Display	50
5.7.4.1	Automatic Brightness	50
5.7.4.2	Minimum Brightness	50
5.7.4.3	Maximum Brightness	50
5.7.4.4	Get Brighter In	50
5.7.4.5	Get Darker In	50
5.7.4.6	Brightness	50
5.7.4.7	Night Mode Darkness	51
5.7.5	Files	52
5.7.5.1	Profiles	52
5.7.5.2	Waypoints and Tasks	52
5.7.5.3	Airspace File	53
5.7.5.4	Logbook	54
5.7.5.5	FlarmNet file	54
5.7.6	Logbook	55
5.7.8	Graphics	56
5.7.8.1	Indicator Setup	56
5.7.8.2	Map	57
5.7.8.3	Airspace	58
5.7.8.4	Waypoints	59
5.7.8.5	Glider and Track	59
5.7.8.6	Thermal Assistant	60
5.7.8.7	Task	61
5.7.8.8	FLARM	63
5.7.8.9	Modes	64
5.7.9	Sounds	64
5.7.9.1	Equalizer Option	64
5.7.9.2	Vario Sounds	65
5.7.9.3	FLARM Sounds	66
5.7.10	Obs. Zones	67
5.7.11	Warnings	68
5.7.11.1	FLARM Warnings	68
5.7.11.2	Altitude Warnings	68
5.7.11.3	Airspace Warnings	69
5.7.11.4	Visual Messages/Warnings	70
5.7.11.5	Voice Warnings	71
5.7.12	Units	71
5.7.13	Hardware	72
5.7.13.1	Digital Inputs	72
5.7.13.2	Communication Setup	73
5.7.13.3	Battery Setup	75
5.7.13.4	Remote Stick (NEW)	77
5.7.13.5	Flaps	78
5.7.13.6	AHRS	78
5.7.13.7	CAN Bridge	79
5.7.13.8	FLARM	81
5.7.14	Polar and Glider	83
5.7.14.1	Polar	83

5.7.14.2	Speeds	84
5.7.14.3	Flaps	84
5.7.15	Profiles	85
5.7.16	Password	86
5.7.16.1	List of Password Functions	86
5.7.17	Admin Mode	87
5.7.18	About	87
6	Variometer and Altimeter	88
6.1	Altimeter	88
6.2	Speed Command	88
7	HAWK	89
7.1	Introduction	89
7.2	Wind Model	89
7.3	The potential climb rate	92
7.4	The Aerodynamic Model	92
7.5	Dynamic behaviour	96
7.6	HAWK system activation	96
7.7	Setup parameters	96
7.7.1	Netto Vario	96
7.7.2	Vario	96
7.7.3	Relative Vario (Super netto)	96
7.7.4	Levelling AHRS	97
7.7.5	HAWK Parameters	97
7.7.6	Graphical display	97
7.7.7	Audio source	97
8	Flying with the LXNAV S8x/S10x	98
8.1	On the Ground	98
8.1.1	Power on Procedure	98
8.1.2	Set Elevation and QNH	98
8.1.3	Pre-Flight Check	99
8.2	Airborne	99
8.2.1	Final Glide Calculation	99
9	Installation	100
9.1	Installing the LXNAV S8x/S10x	101
9.2	Connecting the LXNAV S8x/S10x	101
9.3	Cut-outs	102
9.3.1	Cut-Out for S8 and S10	102
9.3.2	Cut-Out for S80 and S100	102
9.4	Available Cables for GPS/FLARM and PDA Ports	103
9.5	Installation of Options	104
9.5.1	S8xD Option (Repeater)	104
9.5.1.1	Data Exchange	104
9.5.2	Flap Sensor (Flap – CAN)	105
9.5.3	Universal Flap Sensor (Flap – CAN, Flap - 485)	105
9.5.4	MOP2-CAN	105
9.5.5	MOP2-UNI	105
9.5.6	Remote Stick (Remote-CAN)	105
9.5.7	AHRS Option and HAWK option	106
9.5.7.1	Activation using a license file	106
9.5.7.2	Activation using a license key	107
9.6	Ports and Wiring	108
9.6.1	LXNAV S8x/S10x Ports	108

9.6.1.1	LXNAV S8x Ports	108
		108
9.6.1.2	LXNAV S10x Ports	108
9.6.1.3	PDA Port (RJ45)	108
9.6.1.4	GPS Port (RJ12)	109
9.6.1.5	Main Port	109
9.6.1.6	Audio Port	109
9.6.1.7	LXNAV S8X Wiring	110
9.6.1.8	LXNAV S10x Wiring	111
9.6.1.9	LXNAV S8xD/S10xD Wiring	111
9.7	S8x/S10x Configurations	112
9.7.1	Symbols	112
9.7.2	Using external BT module	112
9.7.3	Nano/Nano3 – Sxxx - MiniMap	112
9.7.4	Nano3 - Sxxx - Oudie	113
9.7.5	Colibri II – Sxxx - Oudie	113
9.7.6	Colibri/Volkslogger - Sxxx - Oudie	114
9.7.7	Colibri/Volkslogger - Sxxx - Oudie	114
9.7.8	FLARM – Sxxx - FlarmViewX - Oudie	115
9.7.9	FlarmMouse - ADSB – Sxxx - FlarmView - Oudie	115
9.7.10	FlarmMouse – Sxxx - Oudie	116
9.7.11	FlarmMouse – Sxxx – Oudie – Flaps Sensor	116
9.7.12	FlarmMouse - Nano3 - Sxxx - Oudie	117
	PowerMouse + (Nano3) - Sxxx - Oudie	117
9.7.13	S8x/S10x– S8xD/S10xD	118
9.7.14	S8x/S10x– Flarm UNI/MOP UNI –(LX80xx/90xx)	118
	Sxxx Vario Connection to a LXxxxx	119
9.8	Data Transfer	121
9.8.1	S8x/S10x	121
9.8.2	Other Data Transfers	121
10	Firmware Update	122
10.1	Updating LXNAV S10x and S8x Firmware Using a Micro SD Card	122
10.2	Updating LXNAV S8x Firmware Using a Micro SD Card (up to fw. 5.43)	122
10.3	Updating LXNAV S8x Firmware Using a Micro SD Card (OLD Method)	122
10.4	Incomplete Update Message	123
11	FAQ	124
12	Revision History	125

1 Important Notices

The LXNAV S8x/S10x system is designed for VFR use only as an aid to prudent navigation. All information is presented for reference only. Terrain, airports and airspace data are provided only as an aid to situation awareness.

Information in this document is subject to change without notice. LXNAV reserves the right to change or improve their products and to make changes in the content of this material without obligation to notify any person or organization of such changes or improvements.



A Yellow triangle is shown for parts of the manual which should be read carefully and are important for operating the LXNAV S8x/S10xsystem.



Notes with a red triangle describe procedures that are critical and may result in loss of data or any other critical situation.



A bulb icon is shown when a useful hint is provided to the reader.



A cloud icon is shown when this functionality is supported only on S10x-systems.

1.1 Limited Warranty



This LXNAV S8x/S10x product is warranted to be free from defects in materials or workmanship for two years from the date of purchase. Within this period, LXNAV will, at its sole discretion, repair or replace any components that fail in normal use. Such repairs or replacement will be made at no charge to the customer for parts and labour, the customer shall be responsible for any transportation cost. This warranty does not cover failures due to abuse, misuse, accident, or unauthorized alterations or repairs.

THE WARRANTIES AND REMEDIES CONTAINED HEREIN ARE EXCLUSIVE AND IN LIEU OF ALL OTHER WARRANTIES EXPRESSED OR IMPLIED OR STATUTORY, INCLUDING ANY LIABILITY ARISING UNDER ANY WARRANTY OF MERCHANTABILITY OR FITNESS FOR A PARTICULAR PURPOSE, STATUTORY OR OTHERWISE. THIS WARRANTY GIVES YOU SPECIFIC LEGAL RIGHTS, WHICH MAY VARY FROM STATE TO STATE.

IN NO EVENT SHALL LXNAV BE LIABLE FOR ANY INCIDENTAL, SPECIAL, INDIRECT OR CONSEQUENTIAL DAMAGES, WHETHER RESULTING FROM THE USE, MISUSE, OR INABILITY TO USE THIS PRODUCT OR FROM DEFECTS IN THE PRODUCT. Some states do not allow the exclusion of incidental or consequential damages, so the above limitations may not apply to you. LXNAV retains the exclusive right to repair or replace the unit or software, or to offer a full refund of the purchase price, at its sole discretion. SUCH REMEDY SHALL BE YOUR SOLE AND EXCLUSIVE REMEDY FOR ANY BREACH OF WARRANTY.

To obtain warranty service, contact your local LXNAV dealer or contact LXNAV directly.

2 Packing Lists

- LXNAV S8x or S10x main unit
- Main power cable for S8x/S10x + CAN terminator
- Speaker
- GPS cable (S7-GPS-IGC included, other types optional, this cable is included only with the S8x device)
- PDA cable (optional)
- 2x6 mm screw
- Bluetooth antenna 
- GPS antenna 
- Barogram calibration chart 



Second Seat:

- Main S8xD unit
- Y cable splitter (optional, only with remote stick)
- Main 3m CAN cable

2.1 S80 (80mm) Variometer Unit

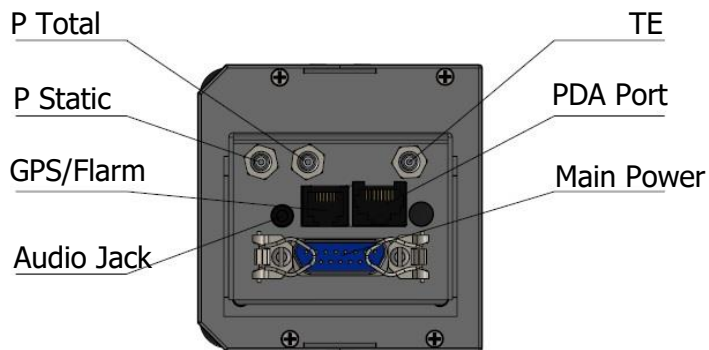
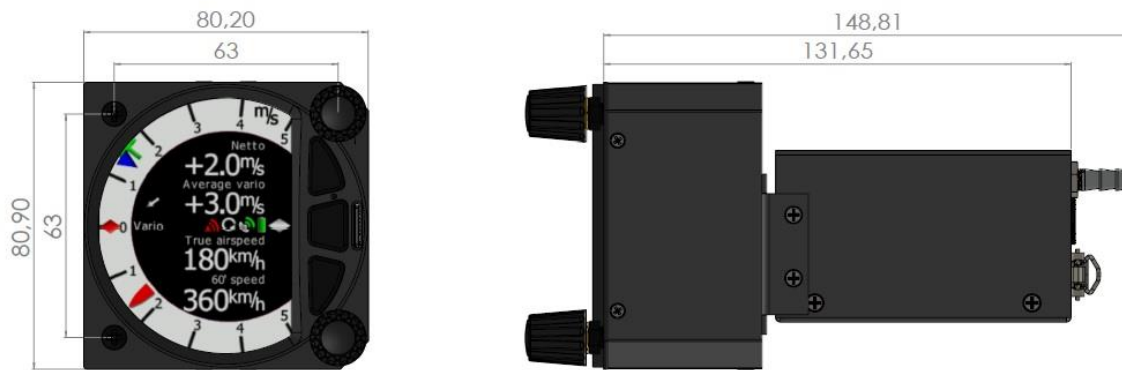

2.2 S8 (57mm) Variometer Unit

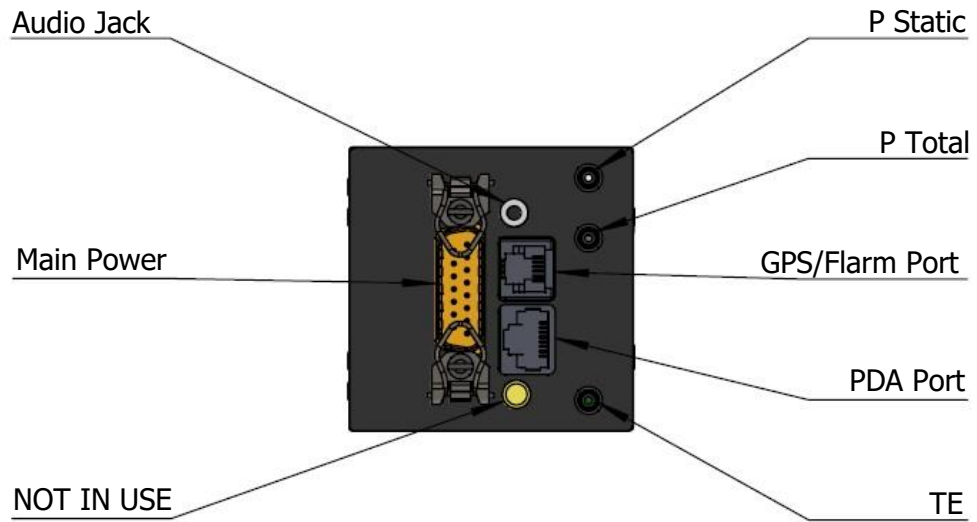
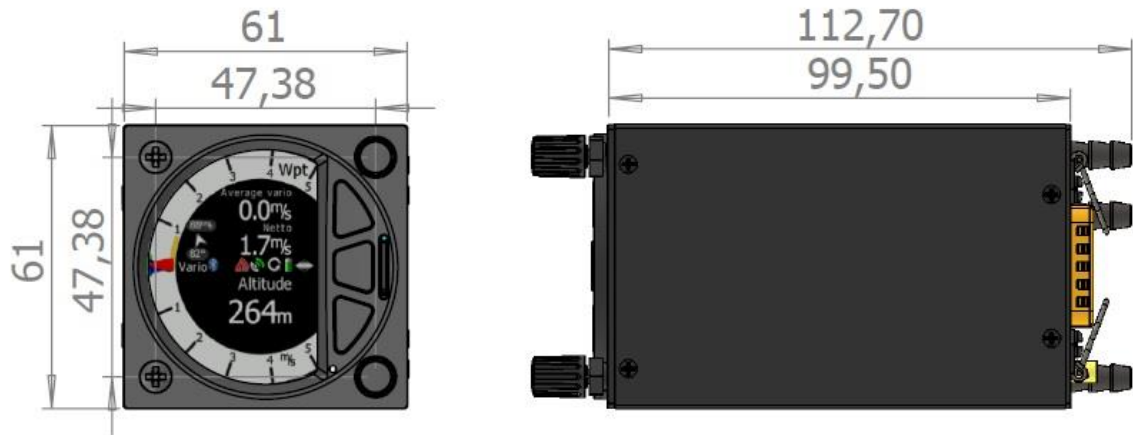

2.3 S10 (57mm) Variometer Unit

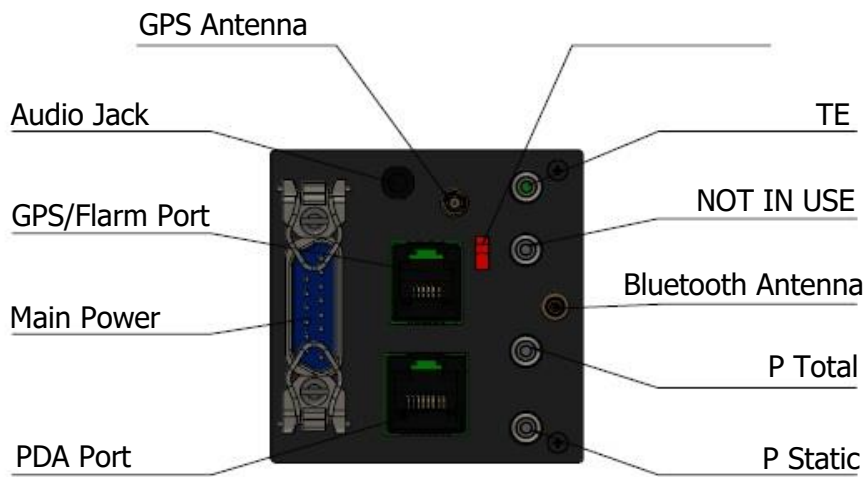
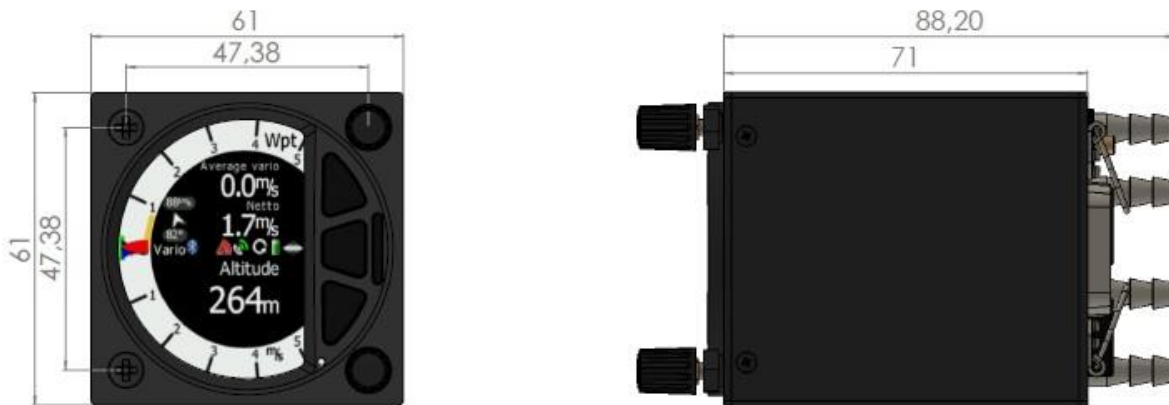

2.4 S100 (80mm) Variometer Unit

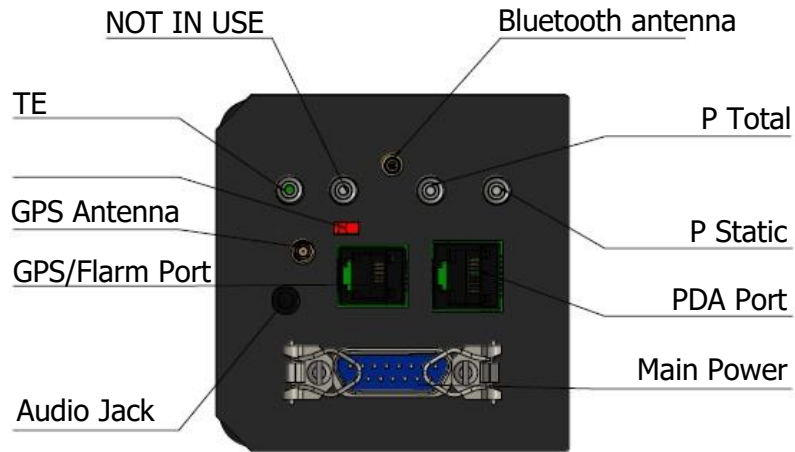
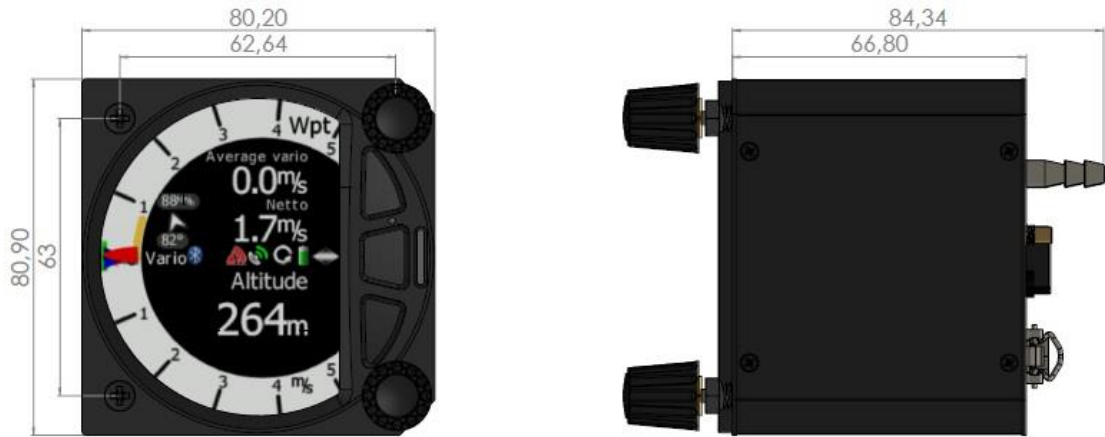

2.5 S10D and S8D Repeater Unit

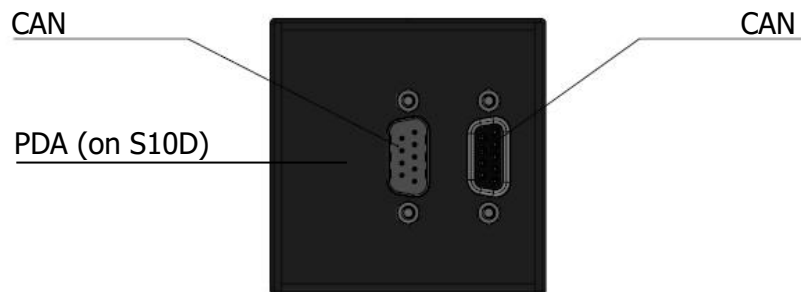
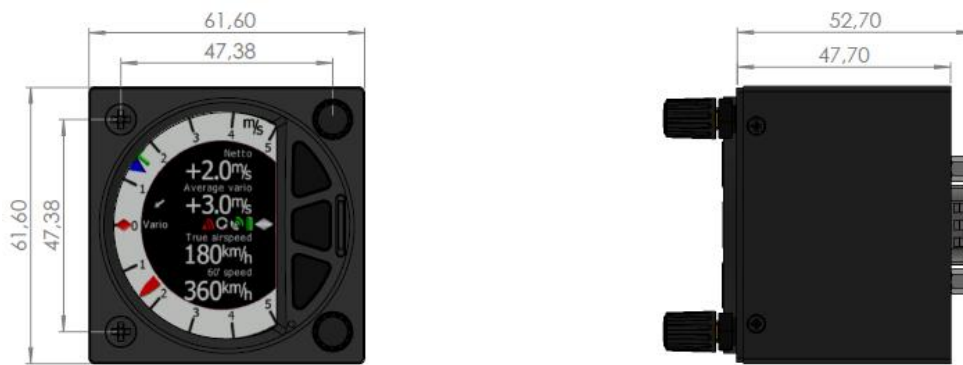

The S10D has also a PDA port, however the S8D does not.

2.6 S100D and 80D Repeater Unit

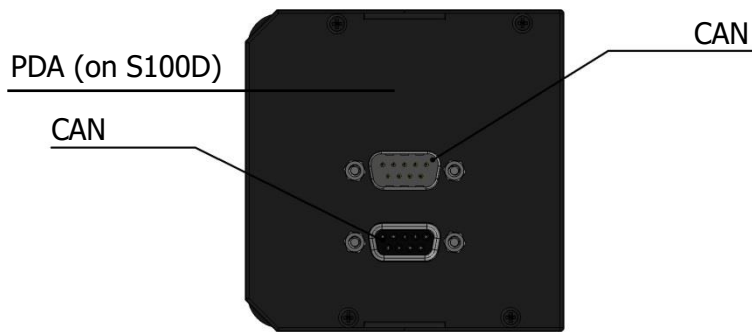
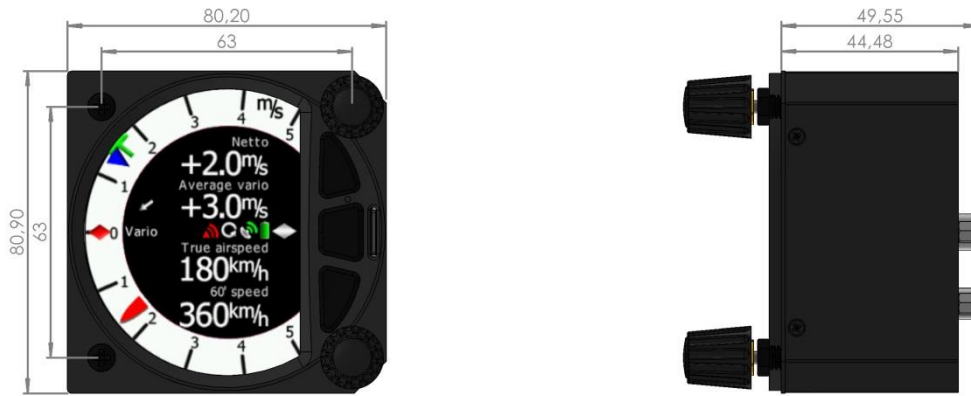

The S100D has also a PDA port, however the S80D does not.

3 Basics

3.1 LXNAV S8x/S10x at a Glance

The LXNAV S8x/S10X is a standalone digital variometer, final glide calculator and navigation system with a simple moving map. The LXNAV S8x/S10x has both GPS/FLARM and PDA/PNA input/output. The unit has standard dimensions that will fit into a glider panel with an opening of 80 mm diameter (3.15") or 57 mm diameter. It is also able to supply a PDA/PNA with power (5VDC/1A). The unit has an integrated high precision digital pressure sensor and inertial system. The sensors are sampled more than 100 times per second. Real Time Data is displayed via a vario needle, an airspace map and up to 4 variable numeric fields displayed on a QVGA 320x240 pixel, 3.5-inch (S80/S100) or 2.5-inch (S8/S10), high brightness (1200 nits) colour display. To adjust values and settings the LXNAV S8x/S10x has two rotary push button knobs and three additional push buttons.





The LXNAV S8x/S10x can be expanded with one or more repeaters (LXNAV S8x/S10x) via the CAN bus. This allows both pilots in a two-seat glider to have independent control of all functions of each unit in the front or the rear seat.



The S10x unit includes a built-in IGC-approved flight recorder, a Bluetooth module and its own backup battery which provides from 3 to 4.5 hours of independent operation.

The S10x is also capable of running [HAWK](#) system, which provides pilot a real-time three-dimensional wind. You can learn more about [HAWK](#) in chapter 7.

3.2 LXNAV S8x/S10x Features

- An extremely bright 3.5" (S80/S100) or 2.5" (S8/S10) QVGA colour display readable in all sunlight conditions with the ability to adjust the backlight.
- Two rotary switches (knobs) with push button function and three push buttons are used for input.
- Pre-loaded polar database for nearly all gliders.
- GPS/FLARM and PDA/PNA input/output.
- FLARM Indication if a FLARM is connected to the GPS/FLARM port.
- Programmable "needles" for selectable data such as netto vertical speed, relative (super netto) and vertical speed (vario).
- 320x240 pixels colour screen for additional information such as average, thermal vario, time, speed etc...
- Many custom audio settings.
- 100Hz sampling rate for very fast response.
- Speed to fly indication.
- TE compensation can be selected to be either pneumatic TE probe or electronic TE.
- Audio equalizer, for custom vario sound performance.
- Audio thermal assistant.
- Built-in high level, IGC-approved flight recorder. 
- Built-in Bluetooth module. 
- Backup battery. 
- Engine noise level sensor (ENL). 
- Built-in GPS module. 

3.2.1 Interfaces

- GPS/FLARM port input/output on RS232 level (RJ12 connector, none-Standard IGC) (12V/2A)
- PDA port input/output on RS232 or TTL level for PDA/PNA devices with 5V power supply (8 pin RJ 45, 5V / 1A).
- Audio port (Standard 3mm phone jack).
- 1Mbit CAN bus for extension to S8xD repeater or Remote stick (CAN remote).

3.2.2 Options

By using a CAN bus system, a second seat device can be connected. The unit installed in the rear seat of the glider is independently powered and receives all the necessary data from the main unit. The communication between both units is exclusively via the CAN bus system (Remote stick, Second seat device).

3.2.3 S8/S80 Club

The S8 Club and S80 Club are special price performance editions of the basic S8 and S80 units. The following features are optional on this device: **Task mode** (see Chapter 5.6), **Digital inputs** (see Chapter 5.7.13.1), **Pilot profiles** (see Chapter 5.7.15) and **Airspaces** (see Chapter 5.7.8.3). Every option can be upgraded separately at any time. To purchase additional options please contact LXNAV.

Device:	S8	S8 Club	S80	S80 Club
TASK mode	Yes	Optional	Yes	Optional
Airspace	Yes	Optional	Yes	Optional
Digital inputs	Yes	Optional	Yes	Optional
Pilot profiles	yes	Optional	Yes	Optional

3.2.4 Technical Data

Power input 10-28 V DC.

3.2.4.1 Power Consumption

Device	Min. Brightness (mA)	Max. Brightness (mA)	Max charge current (mA)
S8	140 at (12V)	190 at (12V)	-
S8D / S10D	90 at (12V)	140 at (12V)	-
S80	140 at (12V)	190 at (12V)	-
S80D / S100D	90 at (12V)	140 at (12V)	-
S10	170 at (12V)	200 at (12V)	Additionally, up to 220mA
S100	190 at (12V)	250 at (12V)	Additionally, up to 220mA



Newer models using brighter displays and consumption might be higher up to 3W.

3.2.4.2 Size and Weight

Device	Size	Weight (g)
S8	57 mm cut-out 61x61x95mm	339
S8D / S10D	57 mm cut-out 61x61x48	210
S80	80 mm (3.15") standard aircraft cut-out 81x81x132mm	460
S80D / S100D	80 mm (3.15") standard aircraft cut-out 81x81x45mm	290
S10	57 mm cut-out 61x61x70mm	348
S100	80 mm (3.15") standard aircraft cut-out 81x81x64mm	515

3.2.4.3 Audio output power

The unit has class D amplifier. The output power depends on speaker impedance.

- 2.6W with 4Ω speaker
- 1.65W with 8Ω speaker.

3.2.4.4 Environmental limitations

- Operating temperature: -20°C to +70°C
- Storage temperature: -30°C to +85°C
- Relative humidity: 0%-95%

4 System Description

4.1 Push Button – Rotary Switches

The two Rotary switches also have a push button function. The LXNAV S8x/S10x detects short or long presses of the push button. A short press means just a click, a long press means pushing the button for more than one second.

4.1.1 Power Button

The system is powered up by pressing any of the push buttons or a press of either of the rotary knobs. A long press of the upper rotary knob will turn the S8x/S10x off. Use this instead of the avionics master switch.

4.2 Rotary Switches

The upper rotary knob is designed for direct volume control. A short-press on the upper rotary knob will produce an option to select between options and adjust volumes for the Vario, Speech and FLARM beep.

A long-press on the upper rotary knob will shut down the system cleanly.



The lower rotary knob is used to adjust settings within the current mode or within menus. With the lower rotary push button, it is possible to toggle between the MC and the Ballast and Bugs settings. In all other menus this knob is used for setting values and editing texts.

4.3 Buttons (Three)

The three buttons between the two rotary knobs have fixed functions. The top button is ESC (CANCEL), the middle is to switch between modes and the lower button is the ENTER (OK) button. The upper and lower buttons are also to rotate between subpages in the WPT and TSK modes.

Push button used for:

- Mode selection
- Confirm option in some menus

Push button used for:

- Switch between modes
- Exit from the menu

Push button used for:

- Mode selection
- Confirm option in some menus

Rotary switch with push button

Enter and operate only in the volume menu

Rotary switch with push button used for:

Adjusting the level of the zoom
Enter/confirm the selection/function

4.4 Switching on the Unit

Pressing any of the buttons or rotary knobs will turn on the S8x/S10x. The first LXNAV welcome screen will appear with the system information (Device name, Version, Serial number...)



The S8xD rear seat unit cannot be powered up before the S8x/S10x has been powered up.

When the boot procedure is completed the setup elevation dialogue will be displayed.



The user must set either the Elevation or the QNH with the lower rotary button. After pressing the lower rotary button, the user can switch between the Elevation and QNH dialogues. As soon as the settings are set the middle button must be pressed to proceed.



The upper push button also has the power OFF function.

4.5 User Input

The LXNAV S8x/S10x user interface consists of dialogues which have various input controls. They are designed to make the input of names, parameters, etc., as easy as possible. Input controls can be summarized as:

- Text editor
- Spin controls (Selection control)
- Checkboxes
- Slider control

To move the function from one control to another, rotate the lower rotary knob as follows:

- Clockwise rotation will select the next control.
- Counter clockwise rotation will select the previous control. The lower PUSH button enters the selected feature.
- Faster rotation of the rotary knob will increase the rate at which the value changes i.e. bigger steps in value.

4.5.1 Text Edit Control

The Text Editor is used to input an alphanumeric string; the picture below shows typical options when editing text/numbers. Use the lower rotary knob to change the value at the current cursor position.

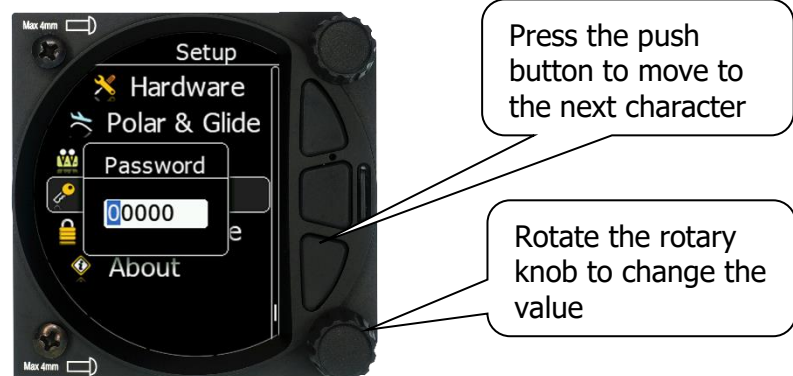

Once the required value is selected, press the lower push button to move to the next character selection. To move back to the previous character, press the upper push button. When you have finished editing, press the Enter key – the lower rotary button. A short press of the middle push button exits from the edited field ("control").

4.5.2 "Spin" Control

"Spin" controls are designed for numeric parameters. Rotate the knob to increase/decrease the selected value. To increase a value in larger steps, spin the lower rotary knob faster.



4.5.3 Selection Control

Selection boxes, also known as combo boxes, are used to select a value from a list of predefined values. Use the lower rotary knob to scroll through the list.



4.5.4 Checkbox and Checkbox List

A checkbox enables or disables a parameter. Press the lower rotary knob to toggle the value. If an option is enabled a check mark will be displayed, otherwise an empty rectangle will be displayed.



4.5.5 Slider Selector

Some values, such as volume and brightness, are displayed as a slider icon.



With a push of the lower rotary button you can activate the slide control and then by rotating the knob you can select the preferred value and confirm it via the push button.

4.6 Switching Off

You will lose your settings if you power down the S8x via the panel master-power switch. The S10x will shut down properly when switching off via the master-power switch.

To archive your settings, you should shutdown device with a long-press of the volume (top) knob.



All settings are saved during the power off procedure. We strongly recommend switching off the unit by using a long-press of the (top) knob.



If the system is powered off via the master switch, changed data will not be saved. Flight parameters at take-off such as target altitude and position will remain in the stored memory so that your final glide calculations are not affected.

5 Operating Modes

The LXNAV S8x/S10x has five operating modes. The middle (Menu) push button toggles through the 5 display modes in a circular way. The diagram below shows the mode structure of the LXNAV S8x. With the upper and lower buttons, it is also possible to move between subpages.

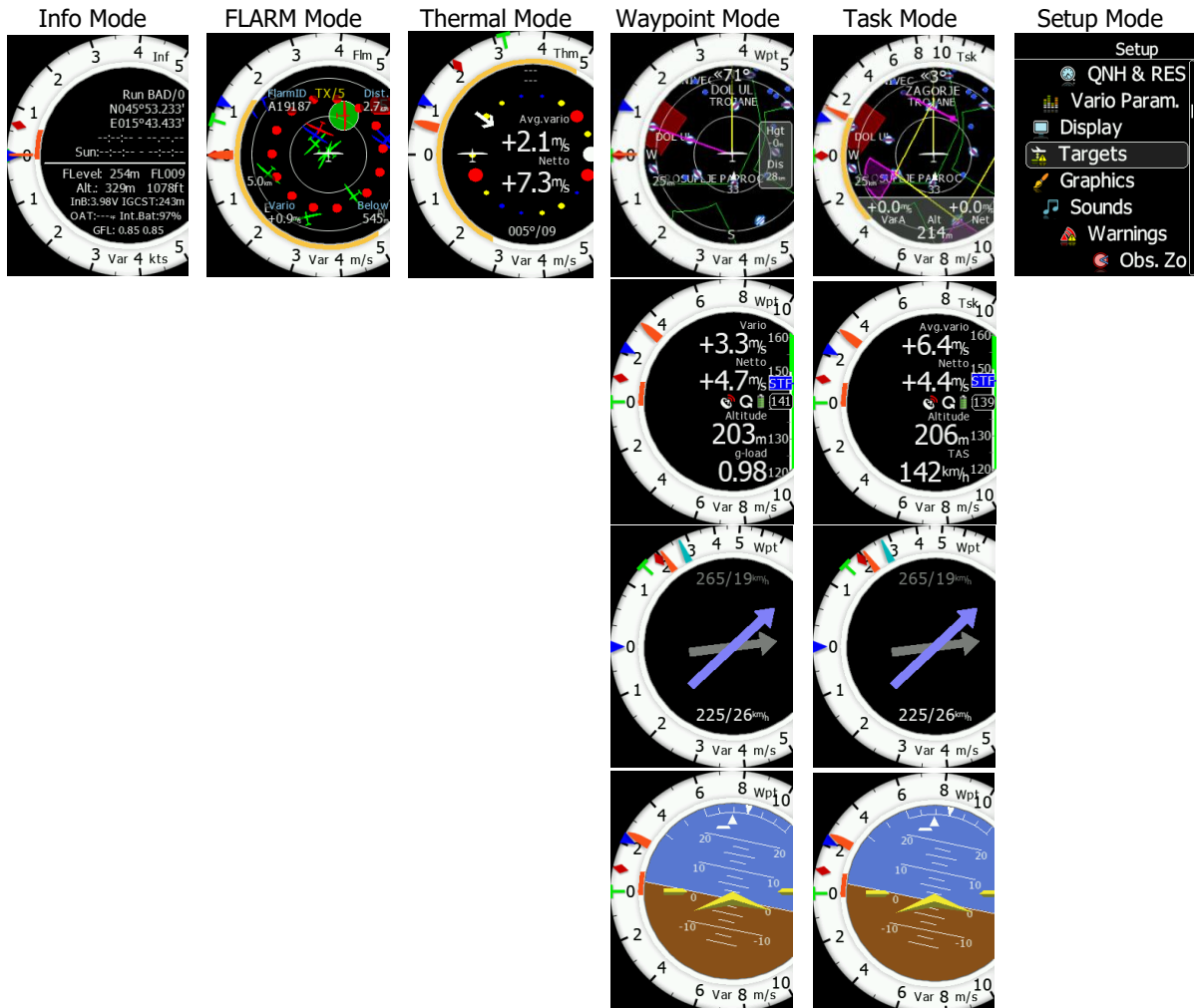

- **Info Mode:** Contains the GPS data, Altitude, Battery and Sunset time, OAT.
- **FLARM Mode:** Showing FLARM targets in range (if a FLARM device is connected to the GPS port).
- **Thermal Mode:** Showing a thermal assistant during circling (S8x only if a GPS source is present).
- **Waypoint Mode:** Simple navigation screen to a waypoint plus subpages (S8x only if a GPS source is present).
- **Task Mode:** Task screen showing the task and airspace plus subpages (S8x only if a GPS source is present).
- **Setup Mode:** For all aspects of the setup of the S8x/S10x.

5.1 Quick Access Menus

For each mode a quick access menu is available, which varies from mode to mode. Items available in quick access menu are:

- MC/BAL
- Reset G
- Layout
- Edit target (only FLARM page)
- FLARM traffic (only FLARM page)
- Select (Only in WPT mode)
- Select Near (Only in WPT mode)
- Send WPT
- WPT elevation (Only in WPT mode)
- Event
- Night
- Edit Task (only in task mode)
- Start (only in task mode)
- Next (only in task mode, visible only after pressing Start)
- Restart (only in task mode, visible only after pressing Start)
- Load (only in TSK mode)
- Save (only in TSK mode)
- Wind (only in WPT and TSK mode)

5.1.1 MC/BAL



To change the McCready value, press the bottom rotary knob and press on MC/BAL. A short press of the lower rotary knob moves from McCready to the Ballast box and pressing the lower rotary knob again will open the Bugs box. If no action is performed within 3 seconds, the box will close, or you can also press CLOSE anytime (lower push button).

5.1.2 Reset G

"Reset G" is a method of re-setting the "G" meter if configured as the yellow bar on the vario scale.

5.1.3 Layout

The sidebar, number and position of navboxes can be defined in this menu. The position (vertical or horizontal) is set by rotating the lower rotary knob. After confirming you can set number of navboxes and also define which navbox you would like to have. The layout setting is different for the numerical or graphical page.

5.1.3.1 Layout in the Numerical Page

In the numerical page the number of navboxes and sidebar can be set. Every navbox can be defined separately.



5.1.3.1.1 Sidebar

The user can select between the different sidebar options that can be displayed on the page (classic Speed to Fly-push/pull bar, Flaps tape, Speed tape and combined Speed & Flap tape). The Speed to Fly bar is dynamic.



5.1.3.2 Layout in the Graphical Page

In the graphical page navboxes can be vertical or horizontal (2 types). The sidebar cannot be set in this page. Every navbox can be defined separately.



5.1.3.2.1 Editing Navboxes

You can select the required data for the highlighted navbox. A short press of the lower rotary knob selects the desired setting and returns you to the navbox selection. Selecting the EXIT (middle) button at any time saves the setting and moves to the main mode.



List of available navboxes:

Type	Navbox title	Description
Altitude (m)	Alt	Altitude in Meters
Altitude (ft)	Alt	Altitude in Feet
Flight level	FL	Flight level
Hgt.above tkoff.	Hgt	Height is the vertical distance above takeoff.
Total Altitude	Alt T	Altitude which considers also the kinetic energy
Standard altitude	AltS	Altitude above 1013.24hPa
Gained altitude	AltG	Gained altitude in last thermal
Current vario	Var	Current vertical speed
Netto vario	Net	Vertical speed of air mass
Vario average	Var A	Average vario (average vario time can be set)
Netto average	Net A	Average vertical movement of air mass
Thermal avg.	Thrm	Average vario from beginning of circling (Green T)
HAWK Avg.Net	hNetA	HAWK netto average
HAWK Avg.Var	hVarA	HAWK vario average
HAWK sideslip	hSlip	HAWK sideslip angle
HAWK AOA	hAOA	HAWK angle of attack

True airspeed	TAS	True airspeed
Indicated airspeed	IAS	Indicated airspeed
Last 60' speed	Sp60'	Average speed for last hour
Ground speed	GS	Speed over ground, taken from GPS
Speed to fly	STF	Calculated speed to fly from MC setting (McSpeed)
Ground Track	Trk	Track over ground taken from GPS
Magnetic Heading	Hdg	Heading (from compass)
Current glide ratio	E	Glider current glide ratio in last three minutes
Theor.glide ratio	theE	Theoretical glide ratio including wind into account
Gliding efficiency	glE	Ratio between current E and theoretical E
Local Time	Time	Local time
Flight time	Flt T	Airborne time
G-load	g	G load – current
G-load min.flight	gmin	Minimum g-load during flight
G-load max.flight	gmax	Maximum g-load during flight
MacCready L/D	Emc	Calculated glide ratio at selected McCready value
MacCready	Mc	McCready setting
Active freq.	COM	Active frequency
Standby freq.	STBY	Standby frequency
XPDR Transp.	XPDR	Transponder frequency
Outside temp.	OAT	OAT – Outside air temperature
Battery voltage	Battery	Battery voltage
Average wind	Wind	Wind direction and speed
Wind comp.	cWnd	Wind component (first number is component calculated from GS-TAS / second number is a component from a Wind vector)
Flap Current		Current flap position
Flap Requested		Requested flap position
Distance	Dis	Distance to the target in meters
Distance (nm)	Dis	Distance to the target in nautical miles
Bearing to target	Brg	Bearing to the target if GPS is present
Steering course	To	Steering course to the target
Radial	Rdl	On radial of selected target
Arrival altitude	Arr	Arrival altitude on target
Arrival for Mc0	Arr0	Arrival altitude on target with Mc=0
Required alt.	ReqA	Required altitude to real target elevation (without safety altitude taken in account)
Required L/D	reqE	Required glide ratio to the target
Frequency	Freq	Target frequency
Task remain distance	tDis	Task remaining distance
Task req. L/D	tskE	Required glide ratio to task finish
Task arrival Mc0	tAr0	Arrival altitude on task with Mc=0
Leg cross distance	xTrk	Off distance from the task leg
Task Remain.time	tRemain	Task remaining time



The safety altitude has no influence on the required alt calculation!



To configure navboxes in SC mode on the ground you must first turn Auto SC off, configure your navboxes and then set Auto SC back to your preferred setting.

The unit will automatically switch between SC to VARIO navboxes, when switching from SC to VARIO mode or vice versa

5.1.4 Select / Select Near (Only in WPT mode)

To select a waypoint, rotate the lower rotary knob to highlight the select option and then press once. This will open the Waypoint list.



A waypoint can be selected from the alphabetical list of waypoints (see uploading files in Chapter 5.7.5.1). Rotating the lower rotary knob moves you through the waypoint list in alphabetical order, clockwise increases the value, counter-clockwise decreases the value. To select the first letter of the desired waypoint, rotate the lower rotary knob, then press the lower push button to move to the next selection of the letter. Rotate the lower rotary knob until the second letter of the required waypoint is highlighted and then repeat the process until the required waypoint is the only selection available. Press enter (lower rotary button) to select the waypoint. The screen will then change back to the navigation mode and show a line to the waypoint, waypoint name and the relative bearing.

Select **Near** to select a WPT from the list which is sorted by distance from the current location. You can sort waypoints by Name/Distance and Bearing by pushing the upper or lower push button. Selection of a WPT is as described above.

5.1.5 WPT Elevation

WPT elevation can be modified in this menu (can be raised or lowered).

Changing elevation will have consequences on most of the navboxes, so please pay attention before changing its parameters!

5.1.6 Edit Target

The user can edit the FLARM target details.

5.1.7 FLARM Traffic

This mode shows all available FLARM traffic around the glider with their FLARM ID codes; the user can also edit all FLARM object data.

5.1.8 Event

Event is used to log an event. The recording rate will be increased to 1 second for one minute.

A message "Event marked" will be displayed on the screen. 

5.1.9 Night

Selecting night will cause the unit's brightness to be decreased to its minimum. Pressing again on "night" will reset the brightness to the value defined under **settings**.

5.1.10 Edit Task (Only in Task Mode)

Selecting the **edit** task via a short press of the lower rotary knob will enter the task editing screen. The first time you edit a task it will be blank. A short press of the lower rotary knob will open another menu with the option to:

- Edit,
- Insert,
- Delete,
- Zone,
- Delete All
- Options

Selecting Insert will allow you to enter a waypoint from the list as a start point. Rotating the lower rotary knob moves you through the waypoint list in alphabetical order, clockwise increases the value, counter-clockwise decreases the value. To select the first letter of the desired waypoint, rotate the lower rotary knob, then press the lower push button to move to the selection of the next letter. Rotate the lower rotary knob until the second letter of the required Waypoint is highlighted and then repeat the process until the required waypoint is the only selection available. Press ENTER to select the waypoint. Once the start point is selected, rotate the lower rotary knob clockwise and click to select the second turn point. Edit the second turn point as above. Repeat for all the points in the task. When you have completed editing the task, press the (middle) button to save the task and return to the Task navigation mode.

You can also change the Observation zone from the defaults for each Waypoint. To do this select EDIT TASK->select waypoint in the task and then press the lower rotary knob. The quick access menu allows you to **insert, edit, delete, delete all** task, change the **zone** for the Waypoint, or edit **task options**. If you select **Zone** you can modify the zone for that specific waypoint only.

Finish zone has an option to enter its elevation and check to navigate to the nearest point of the zone.

Final glide will be calculated to the **elevation of the finish zone** including polar, MC, BUGS and safety altitude.

If **navigate to the nearest point** is checked, the final glide will be calculated to the **edge of the zone** and not to the centre.



Navigate to near point is possible

5.1.10.1.1 Task options

Under task options are available setting for **Event procedure** start of the task.

When **event start procedure (PEV Start)** is in use, pilot must record an event before crossing the start line or exiting start zone. After pressing the event button, a wait time period starts (**wait before**). When this period finishes, start interval (**start period**) will open in which a penalty-free start may be made.

Press EVENT button to trigger event start procedure. An **Event Marked! (x)** message with number of events will appear. If you have enabled nav box for **Event Proc.**, you will see time counting down. For **waiting period**, the title of the nav box will show **WAIT!**. Once count down is finished a message "Start window is open." will be shown and start interval countdown start count down, the title will show **GO!** message. When pilot sees this countdown, a penalty free start can be done.

When time of the start window is over, the title of the nav box will show **CLOSED** message. Event button may be pressed at any time, up to a total of **Max.events** times. Each press of PEV cancels the previous start window and restarts the wait time timer.



Multiple events recorded within 30 seconds will be treated as a single event at the time of the first event of the cluster.

On the next timeline a scenario with **Event Proc.** Nav box is shown. It is assumed that wait time interval is 20 minutes, start window is 8 minutes and maximum number of events is three.

The PEV has been triggered at **11:55**. Now we are waiting for **20 minutes**, until **12:15**.

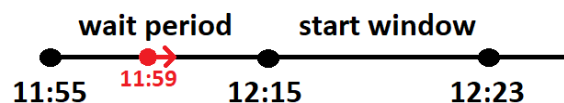

At **12:15**, you will get a message, »**Start window is open**«. Now we have 8 minutes of the time to cross the start line without penalties.

At **12:23** you will get a message »**Start window is closed**«

We can repeat start procedure for »**Max Events**« times. When the number of events exceeded the number of **Max.Events**, there will be a title in the Nav box "**MAX.PEV**".

5.1.11 Start Task (only in Task Mode)

Selecting **start** followed by a short press of the lower rotary knob will start a task.

5.1.12 Restart Task (only in Task Mode)

Selecting **restart** followed by a short press of the lower rotary knob will restart the task.

5.1.13 Next Waypoint (only in Task Mode)

Selecting **next** followed by a short press of the lower rotary knob will advance the task to the next waypoint in the task.

5.1.14 Send WPT

With pressing that option, selected waypoint will be sent to SxxxD unit.

5.1.15 Load/Save

In the Load menu you can create files to load into the instrument or you can upload them to the instrument via the SD card. To save the currently active task select Save in the quick access menu. The task will be saved in the internal memory.



Be aware to insert the SD card facing the right way to avoid damage to instrument or the card itself. Micro SD card must be inserted with pins facing away from the screen (top of the card facing towards the screen).

5.1.16 Export

Every task can be exported to the external sd -> to a .cup file on the SD card.

5.1.17 Wind

Here you can switch between automatic wind calculation by the instrument or setting the wind parameters yourself. When Wind calculation is disabled you can manually set the wind speed and direction.



5.2 Info Mode

The Info Mode gives you a snapshot of the GPS position, date and time along with the Flight level, altitude, Battery status and FLARM status. The Flight Level equivalent is also available in meters or feet as is the Altitude navbox.



Description:

- The logger status is displayed as Stop or Run. You can also set logger to be always turned on (see Chapter 5.7.2.4).
- The GPS status is displayed as OK, BAD, NODATA together with the number of satellites.
- Latitude and longitude
- Local time and date
- Sunrise and sunset time.
- Flight level also in meters
- Altitude in meters and ft
- Battery status
- IGCAIt – IGC altitude (altitude read from the IGC sensor)
- FLARM status (TX – transmits data / and a number of received FLARM devices)
- OAT – outside air temperature
- GFL – G-force levels. Minimum and maximum recorded G-force level

5.2.1 Quick Access Menu

A short press of the (lower) rotary button activates the Quick Access menu.

5.3 FLARM Mode

If the S8x/S10x is connected to a FLARM source via the GPS port (in the S10x called the FLARM port) then the FLARM Mode will display a map of the relative positions of FLARM targets that are within range. By rotating the lower rotary knob you can change the range of the display from 0.5 km to 150 km. Switching between FLARM targets is possible via the up/down button. Data from a selected FLARM object can be seen in 4 corners: FLARM ID, Distance, Vario and Relative altitude (Above / Below). There is also an indication of how many FLARM objects are present displayed as: TX/number.



This mode can be disabled via Setup>graphics>modes>FLARM mode.



Distance, relative altitude and vario indications are related to the selected target.

5.3.1 Quick Access Menu

A short press of the lower rotary button activates the Quick Access menu.

5.3.1.1 Edit Target

The user can edit the following FLARM objects data:

- FLARM ID
- Competition sign
- Pilot
- Aircraft type
- Registration
- Airfield
- Communication frequency (object's communication frequency)

These settings can be accessed by pressing the lower rotary button, selecting EDIT target and then modifying the data of interest.

5.3.1.2 FLARM Traffic

All FLARM objects in range are displayed in this mode. The following details are shown:

- FLARM target ID
- Relative distance
- Vertical speed (vario data from the object)
- Relative altitude

If you press on the selected FLARM target you can enter the edit target menu where you can insert a target's data.

5.3.2 FLARM Warnings

Regardless of which Mode you are in, if a FLARM target triggers an urgent (third warning level) or important (second warning level) warning then the screen will change to the FLARM warning mode automatically.

Extract from the FLARM Operating Manual:

Warnings are given in order of the time remaining before a potential collision, not the geometrical distance. The first warning level for another aircraft or an obstacle is delivered at less than 19 - 25 seconds before the possible collision; the second warning level is delivered at less than 14 - 18 seconds before; the third level at less than 6 - 8 seconds before.



The warnings continue as long as FLARM calculates a threat of collision. The warning level may decline or be cancelled, depending upon the prediction. The warnings are selective; they are only issued if the calculation reveals a high probability of collision in the near future.

5.4 Thermal Assistant Mode



The Thermal Assistant mode displays a graphical representation of your location within the thermal. If you are thermaling to the left, there will be an aircraft symbol on the right of the ring of bubbles and the bubbles will appear to rotate clockwise (towards the symbol of the glider). If you are in a right-hand thermal there will be an aircraft symbol on the left and the ring of bubbles will appear to rotate anticlockwise (towards the symbol of the glider). Large red bubbles indicate the strongest lift within the thermal and small blue dots indicate the weakest lift or sink within the thermal. Yellow bubbles indicate lift equal to your MacCready setting, average thermal or average climb rate depending on your preferred setting (refer to Chapter 5.7.8.6.1). The point of strongest lift is indicated by a white large bubble.

You can use the thermal assistant to visually determine which part of the thermal has the strongest lift and adjust your turn accordingly to manoeuvre the glider in the direction of the strongest lift and away from the weakest lift or sink.

The thermaling assistant can be set to automatically change to the Thermal assistant mode or it can be manually selected. See Chapter 5.7.8.6.2 for settings.

The two navboxes within the Thermal Assistant Mode can be configured using the quick access menu. If **HAWK** option is activated, the **HAWK** parameters can be used for these two navboxes as well.



This page can be configured via: Setup->graphics->modes->thermal mode.



Look out of the cockpit!

Looking into thermal assistant might be life-threatening for you and other pilots in the thermal.

5.4.1 Quick Access Menu

A short press of the (lower) rotary button activates the Quick Access menu.

5.5 Waypoint Mode

The Waypoint Mode is a quick access screen to provide simple navigation to a Waypoint or Airport. By rotating the bottom rotary knob, you can vary the range of the display from 0.5 km to 100 km.



The first page shows a line to a selected waypoint, the name of the selected waypoint at the top of the screen and the relative bearing with chevrons indicating the direction to turn towards the selected waypoint.

5.5.1 Quick Access Menu

A short press of the (lower) rotary button activates the Quick Access menu.

5.5.2 Numerical page

The Waypoint mode has a second page which contains numerical data. Default are 4 navboxes: Average Vario, Netto, Altitude and True Airspeed. In addition, the central line shows the status of the FLARM, GPS, Cruise/Climb and battery status. This second page can be selected by pressing the lower push button once. You can return to the Waypoint navigation mode by pressing the upper push button (top button of the three).

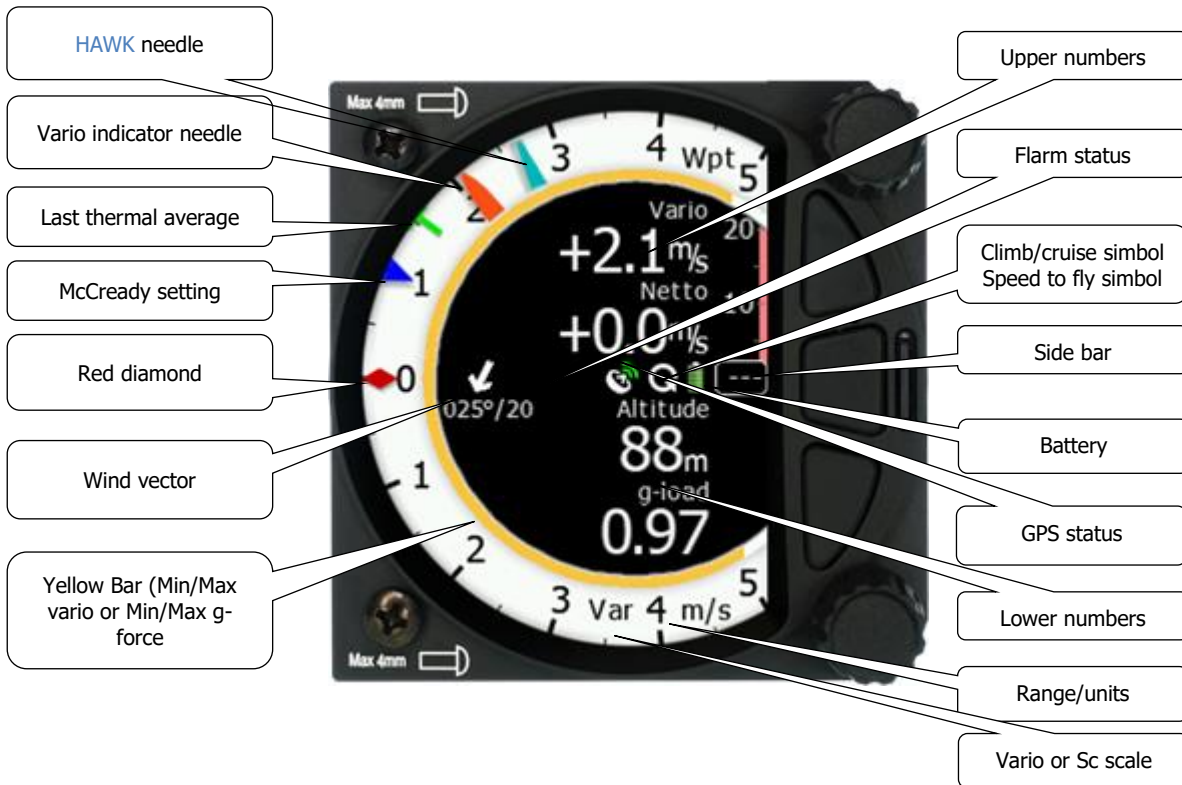

The Vario **Needle** can display: the Vario, Netto, Relative or Speed to fly value (Setup->Hardware->Indicator). The scale can be chosen in the range of +/-5 +/-10 or +/-20. The cursor style can be thin, medium or thick. It can be linear or non-linear (setup->graphics->indicator). Within the software the range can be set to m/s, kts, km/h, mph or fpm (in Setup, Units, Vertical speed).

The **HAWK** needle will show same parameter as Vario needle but calculated with **HAWK** system. To learn more about **HAWK** setup see chapter 7.7.1 and 7.7.2.

- **SideBar** can be configured to display a Speed to fly bar, Speed tape or flap tape. The **Speed to fly bar symbol** indicates which speed you must fly relative to the current MacCready setting, sink rate and speed. One arrow means 10 units of speed faster or slower. **Speed Tape** represents the Indicated Air Speed (IAS) in speed tape form depending on the speed settings (see Polar & Glider - Speeds). The speed tape will change colour from green, yellow to red depending on the settings and the IAS. **Flap Tape** can display the recommended flap position. If a Flap sensor is present on the CAN bus, the flap tape will also display the actual flap position. **Speed and Flap tape** is a mix of both, speed and flap tape.
- The **Red diamond** symbol can show Netto, Average Netto, Average vertical speed or G-force.
- The **Blue arrow** symbol shows the current MacCready value.
- The **Green T** symbol represents last thermal average value.

- The **Yellow Bar** can show Max and Min values of vario over defined time (average vario) or G meter (over whole flight).
- The **FLARM Status** symbol indicates the presence of a FLARM unit (grey), if the FLARM receives any data from other FLARM units, the symbol becomes red.
- The **GPS** symbol is green when the GPS status ID is OK, and red when GPS status is bad. If GPS data is not detected, the symbol will disappear.

The numerical navboxes can be changed using the Quick Access menu with a short press of the lower rotary knob followed by selecting navbox from the menu and a further short press of the lower rotary knob. With the first navbox highlighted with a yellow border you can scroll through the four navboxes using the lower rotary knob. Select the navbox you wish to change with a short press of the lower rotary knob. This will open a list of available navboxes.



Select the required navbox and then save this with a short press of the lower rotary knob. Repeat the process for any other navbox that needs to be changed.

5.5.3 Wind Page

On this page live wind vector and averaged wind vector are shown. Live wind is presented in blue colour when **HAWK** option is active otherwise it is in white colour. Second grey coloured arrow in the background is used for averaged wind. Average wind is calculated from all checked wind methods.

Wind arrows are always drawn relative to glider orientation. E.g.: If arrows are pointing downward, it indicates head wind. If arrows are pointing left or right, it means side wind.



When using **HAWK** option, default average time for wind is set to 30 seconds. User can modify it in Vario parameters. If **HAWK** option is not used, averaging time is fixed to three minutes. To learn more about **HAWK** see chapter 7.

5.5.4 AHRS Page

The Waypoint mode has a fourth page which displays the AHRS (To enable this feature refer to chapter 9.5.7).



The Pitch offset can be adjusted via the lower rotary knob.



For competitions the artificial horizon can be disabled via the Setup>Hardware>Ahrs menu. See chapter (5.7.13.6) for more details. When the artificial horizon page is active a BFION event is written to recorded flight for verification purposes.

5.5.5 Quick Access Menu

A short press of the (lower) rotary button activates the Quick Access menu.

5.6 Task Mode

The task mode can display a navigation page including airspace and a task. By rotating the lower rotary knob, you can change the range of the display from 0.2 km to 100 km.



Task mode is not enabled on the S8/S80 Club version. To purchase this option please refer to Chapter 3.2.3.

5.6.1 Numerical Page

The Task mode has a second page which contains numerical data. Defaults are Average Vario, Netto, Altitude and True Airspeed. The central line also displays the status of the FLARM, GPS, Cruise/Climb and battery. This second page can be selected by pressing the lower push button once. You can return to the task navigation page by pressing the upper push button.



The navigation boxes in this second task page can be changed using the Quick Access menu and selecting **navbox**.

5.6.2 Wind Page

On this page live wind vector and averaged wind vector are shown. Live wind is presented in blue colour when **HAWK** option is active otherwise it is in white colour. Second grey coloured arrow in the background is used for averaged wind.

Wind arrows are always drawn relative to glider orientation. E.g.: If arrows are pointing downward it indicates head wind. If arrows are pointing left or right it means side wind.



When using **HAWK** option, default average time for wind is set to 30 seconds. User can modify it in Vario parameters. If **HAWK** option is not used, averaging time is fixed to three minutes. To learn more about **HAWK** see chapter 7.

5.6.3 AHRS Page

The Task mode has a fourth page which displays the AHRS (To enable this feature refer to chapter 9.5.7).



The Pitch offset can be adjusted via the lower rotary knob.



For competitions the artificial horizon can be disabled via the Setup>Hardware>AHRS menu. See chapter (5.7.13.6) for more details. When the artificial horizon page is active a BFION event is written to recorded flight for verification purposes.

5.6.4 Quick Access Menu

A short press of the lower rotary knob activates the Quick Access menu. The following menus are available:

- MC/BAL
- Start
- Edit task
- Load
- Save
- Delete
- Wind
- Layout
- Reset G
- Event

- Night



Changing the Start, Edit task, MC/BAL is the same as Page 1 of the Task mode.



5.6.4.1 Editing navboxes

Selecting the navboxes option and then pressing the bottom rotary knob will allow you to select one of the three boxes by rotating the lower rotary knob followed by a short press. You can then select the required data for the highlighted navbox. A short press of the lower rotary knob selects the desired setting and returns you to the navbox selection.

Pressing the EXIT (middle) button at any time saves the setting and moves to the main page.

5.7 Setup Mode

The setup mode allows you to change the configuration and base settings for the S8x/S10x vario.



Following items are listed in the setup menu:

- QNH &RES
- Flight recorder
- Vario parameters
- Display
- Files
- Logbook
- Graphics
- Sounds
- Observation Zones
- Warnings
- Units
- Hardware
- Polar & Glider
- Profile
- Password
- Admin mode
- About

You can scroll up and down the list of settings by rotating the lower rotary knob and selecting a setting to change with a short press of the lower rotary knob.



All menus have the EXIT button which will exit to the previous menu. You can also exit from the menu if you press the middle push button.

Some of the options have sub menus and these are selected in the same way.

5.7.1 QNH & RES

Turn the lower rotary knob to select the required entry field. Press the lower rotary knob to select it and start editing the value. A further short press will enter the value.



5.7.1.1 QNH

This feature may be used to offset the altitude datum as the result of pressure changes during the flight. Since changing the QNH influences the indicated altitude, care should be taken when changing the value as an incorrect setting could upset the final glide calculation.

5.7.1.2 Safety Altitude

This setting is the altitude reserve or safety altitude and is the height that the instrument adds to the final glide altitude required so the glider arrives over the final glide destination at the selected safety altitude. Once the safety altitude has been specified, the pilot must keep the final glide indicator on 0 to arrive at the safety altitude (setup one of the navboxes in the primary or secondary pages of waypoint or task modes to be Arrival Altitude).



5.7.2 Flight Recorder

The S10x vario system has a built-in IGC-approved flight recorder. In this menu the user can set flight recorder parameters and the pilot's data.



The S8x version 6 or higher also has a flight recorder which does not have a digital signature and therefore is not approved for badge flights according IGC standards.

5.7.2.1 Recording Interval

Set the recording interval from 1 – 20 seconds.

5.7.2.2 Auto Finish

If this functionality is enabled, the flight recorder will automatically finish the flight under the following conditions:

- GPS status OK
- Groundspeed lower than 20 km/h
- True airspeed lower than 40km/h
- Absolute vario lower than 1m/s for 300 seconds

5.7.2.3 Finish Before OFF

If this setting is enabled the flight will be finished if the user powers down the unit.

5.7.2.4 Logger Always ON

This setting will enable logging of flight immediately after power on and will log the flight until the unit is powered down. The only condition to start logging is the presence of a valid time (GPS status BAD or OK). Logging will not start if the GPS status is Very Bad (no valid time present).



Please use this function if you really understand its function. Enabling this function the flight will never finish any you will not see it in the logbook.



This function can create multiple IGC files, depending how many times you have turned OFF and ON the unit.

5.7.2.5 Pilot

Insert the pilot's name which will be stored in the declaration.

5.7.2.6 Co-Pilot

If the system is used in a two-seater the name of the co-pilot may also be entered.

5.7.2.7 Competition Number

Insert the competition number of the glider which is also stored in the flight file.

5.7.2.8 Registration Number

Insert the registration number of the glider which is also stored in the flight file.

5.7.3 Vario Parameters



5.7.3.1 Vario Needle Filter

Vario needle filter sets a time constant of the **Vario** needle. The value can be adjusted between 0.1 and 5 s with step 1.0s or 0.1s. Default value is 2.0 s.

A lower number (0.1s compared to 5.0 s) means very sensitive (fast vario).

5.7.3.2 Vario Sound Filter

Sets a time constant of the **Vario** sound. The value can be adjusted between 0.1 and 5 s in steps of 1.0 s or 0.1 s. Default value is 2.0 s.

5.7.3.3 Netto Filter

Sets a time constant of the **Vario Netto** needle. The value can be adjusted between 0.1 and 5 s in steps of 1.0 s or 0.1 s. Default value is 4.0 s.

5.7.3.4 Relative Filter

Sets a time constant of the **Vario Relative** needle. The value can be adjusted between 0.1 and 5 s in steps of 1.0 s or 0.1 s. Default value is 4.0 s.

5.7.3.5 SC Filter

SC filter sets a time constant of the **Speed-To-Fly** needle. The value can be adjusted between 0.1 and 5 s in steps of 1.0 s or 0.1 s. Default value is 4.0 s.

5.7.3.6 Smart Filter

Using the **Smart vario filter** the vertical speed can be further filtered. The Smart vario filter defines the maximum speed of the vario needle. "1" is the highest damping, "8" the lowest. "Off" means no additional filtering.

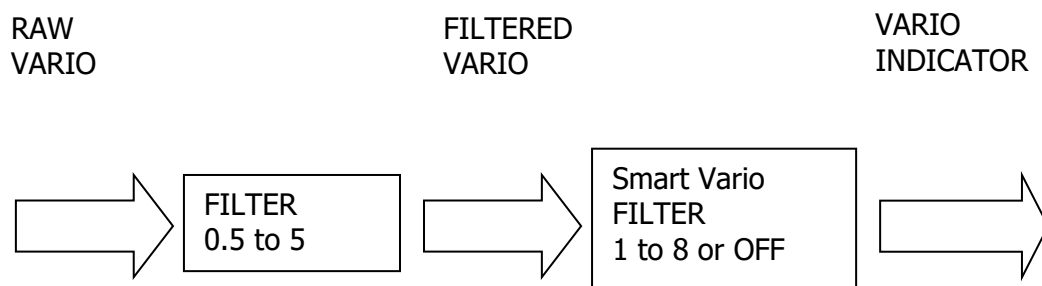

5.7.3.7 Needle Range

Needle range sets the full-scale range of the vario (2.5 m/s, 5 m/s or 10 m/s). Default value is 5 m/s (10 kts).

5.7.3.8 Auto SC (Speed Command)

Auto SC defines the conditions when the instrument (needle) will switch automatically between vario and speed to fly mode. It is just a needle mode.

- **OFF:** Switching exclusively by means of an external switch connected to the S8x/S10x. With new versions of Remote sticks there is no longer a "physical" switch connection between the Remote stick and the Vario unit – it is a switch on the Remote stick which is connected through the RS485 bus.
- **GPS:** When the GPS detects that the glider is circling an automatic change over to vario will happen after approximately 10 seconds. Detection of straight flight will cause a change to speed command.
- **IAS:** When the IAS exceeds a pre-set value. The IAS at which switching occurs can be selected in 5 km/h steps from 100 up to 160 km/h (or the equivalent in knots or mph).
- **G-meter** – for switching between cruise and climb mode based on the G measured by the inertial system. When glider starts circling the S8x/S10x will automatically switch from cruise to climb mode.



The external switch wired to the LXNAV S8x/S10x has absolute priority and will override all other switching methods. VP (Vario priority) input can also override a hard-wired SC switch.



To configure navboxes in SC mode on the ground you must first turn Auto SC off, configure your navboxes and then set Auto SC back to your preferred setting.

5.7.3.8.1 External SC switch not installed

If you do not have an external SC switch or Flap switch, you must do this manually.

The procedure is as follows:

- Go below the hardware input settings
- Assign one of the inputs as a "SC switch"

You have two SC switch states, red and green. One of them will switch the unit to cruise mode and you can change the values on each page.

When done, change the input back to the default and enable SC switch to GPS mode.

5.7.3.9 TE Compensation

The LXNAV S8x/S10x offers two methods of vario Total Energy Compensation:

- Pneumatic TE Pitot tube
- Electronic TE compensation



It is important to note that the method of TE compensation is defined when the instrument is installed by virtue of the pneumatic connections made to the TE and static ports. Changing the compensation type in the setup mode below **WILL NOT** change the method of compensation – the pneumatic plumbing must be changed first.



If the TE pitot tube has been connected, TE compensation should be set to 0%. No further adjustment of the TE compensation is possible. Quality of the TE tube is the one and **only** factor.



For **electronic** TE compensation, connect the TE port to *static*. Set the Vario Param TE compensation **initially** to 100% and then adjust this with flight testing as described below.

5.7.3.9.1 TE Fine-Tuning

The electronic TE compensation can be fine-tuned during flight using the following procedure: It is essential that this is only performed in smooth air; it is not possible to tune the TE accurately in turbulent air.

- Set TE compensation to 100%.
- Accelerate up to approximately 160 km/h (75 kts) and keep the speed stable for a few seconds.
- Gently reduce the speed to 80 km/h (45 kts).
- Observe the vario indicator during the manoeuvre. At 160 km/h the vario will indicate about -2 m/s (-4 kts). During the speed reduction the vario should move towards zero and should never exceed zero.
- If the vario shows a climb the compensation is too low; increase the TE% and vice versa.
- Try another "zoom" to assess the change and make further adjustments if necessary.

Electronic TE compensation is only effective when the Pitot tube and static sources are co-located and the pneumatic lines to the instrument are approximately the same length. The best sensor to use is the combined pitot/static Prandtl tube. If problems are experienced with the electronic TE compensation the most likely cause is the glider's static source.

The static source can be checked by plumbing the pneumatic tubes for electronic compensation and then setting the TE: to 0%. In still air accelerate to approximately 160 km/h (75kts) and slowly reduce the speed to 80km/h (45kts). Observe the vario indicator. If the static source is good the vario should immediately start to move to show a climb. If the needle initially shows increased sink and then moves to a climb, the static source of the glider is unsuitable and there is no way to provide successful TE compensation electronically. The use of a dedicated and accurate fin-mounted pitot/static source such as a Prandtl tube might help.

5.7.3.10 Vario Average Time

Vario average time defines the integration period for the average netto vario in seconds. The default is 20 seconds.

5.7.3.11 Integrator Reset

If this item is enabled the average vario (integrator) will be reset to 0 when switching from SC to Vario mode.

5.7.3.12 Temperature Offset

The LXNAV S8x/S10x is supplied with an external outside air temperature (OAT) sensor. With the offset setting it will correct static errors of temperature measurement.

5.7.3.13 Airspeed Offset

The user has the possibility to make an airspeed offset if the measurement is not correct.

5.7.3.14 **HAWK enable/disable**

Using this checkbox, pilot can switch on/off HAWK system.

5.7.3.15 **HAWK wind variance**

Wind variance smooths the horizontal and vertical wind (netto vario) readings. The larger the value of wind variance is, the more nervous the readings. Recommended value for wind variance is 0.11. To learn more about HAWK system, read chapter 7.

5.7.3.16 **HAWK Horizontal wind average**

Horizontal wind average defines period, which is used for average horizontal wind calculation, which is displayed as grey arrow on wind page.

5.7.3.17 **HAWK Vertical wind average**

Vertical wind average defines period, which is used for average relative and average netto calculation. Both values can be shown as navbox on numeric or graphic page.

5.7.4 Display



5.7.4.1 **Automatic Brightness**

If the Automatic Brightness is checked the brightness will be automatically adjusted between the minimum and maximum parameters set. If the Automatic Brightness is unchecked the brightness is controlled by the brightness setting.

5.7.4.2 **Minimum Brightness**

Use this slider to adjust the minimum brightness for the Automatic Brightness option.

5.7.4.3 **Maximum Brightness**

Use this slider to adjust the maximum brightness for the Automatic Brightness option.

5.7.4.4 **Get Brighter In**

The user can specify in which time period the brightness can reach the required brightness.

5.7.4.5 **Get Darker In**

The user can specify in which time period the brightness can reach the required brightness.

5.7.4.6 **Brightness**

With the Automatic Brightness unchecked you can set the brightness manually with this slider.

5.7.4.7 Night Mode Darkness

Set the percentage of the brightness to be used after a press on the NIGHT mode button.

5.7.5 Files

The Files menu allows you to upload or select Waypoint, Airspace and FlarmNet files.



5.7.5.1 Profiles

Saved profiles on the SD card can be loaded into the device via this menu.

5.7.5.2 Waypoints and Tasks

Selecting the Waypoints and Tasks menu opens a list of .cup files available in the internal memory. Pressing **add new** lists the files present on the SD card. Selected files are automatically loaded into internal memory.



Selected files can be also removed from the internal memory after using **remove** function.



The file size of a waypoint file is limited to 1MB. The supported format is **CUP** as generated with the **SeeYou** program. Some versions of CUP may not be compatible if they are not created according to the **CUP** standard, which is a proprietary format from the Naviter company.



The number of CUP files that can be viewed or selected is 20.

5.7.5.3 Airspace File

Selecting the Airspace menu opens a list of .cub and .lxa (files from ASAPT database) files available in the internal memory. Pressing **add new** lists the files present on the SD card. Selected files are automatically loaded into internal memory.



Selecting a file loads this file for use.



The LXNAV ASAPT database file format is also supported and can be loaded into the system.

5.7.5.4 Logbook

The logbook page lists all the flights sorted by date.



If GPS data is present the logbook will show the date and time of departure. Manual navigation (without GPS) will show the duration and will be marked with "-" marks.



The user can download a flight by a short press on the lower rotary button.

5.7.5.5 FlarmNet file

Selecting the FlarmNet option opens a list of .fln files available on the SD card or in the internal memory. Selecting a file loads it.



Please note that only one FlarmNet file can be active at any one time.

5.7.6 Logbook

The logbook page lists all the flights sorted by date.



If GPS data is present the logbook will show the date and time of departure. Manual navigation (without GPS) will show the duration and will be marked with "—" marks.



The user can download a flight by a short press on the lower rotary button.

5.7.8 Graphics

The Graphics option has sub menus for Map, Airspace, Waypoints, Glider and Track, Tasks, FLARM, Theme setup and Modes.



5.7.8.1 Indicator Setup

Vario indicator graphics and preferences can be adjusted in this menu.



5.7.8.1.1 Needles

When [HAWK](#) option is installed, user can define, if he wants to see only [HAWK](#) (blue) needle, TEK vario (red) needle or both needles.

5.7.8.1.2 Vario Needle

Vario needle means, when your vario is in vario mode. A needle can be set to Vario, Netto, Relative or G-meter. When using [HAWK](#) option it is recommended to set Vario needle to Relative.

5.7.8.1.3 SC needle

SC needle means, when your vario is in SC mode. A needle can be set to Vario, Netto Relative or G-meter. When using [HAWK](#) option it is recommended to set SC needle to Netto.

5.7.8.1.4 Yellow Bar

Yellow bar can be set to G-meter, Min/Max vario or no bar.

5.7.8.1.5 Red Diamond

Red diamond symbol can be set to No diamond, Average, Netto, Average Netto, G-meter or SC.

5.7.8.1.6 MacCready

The blue triangle can be enabled or disabled.

5.7.8.1.7 Thermal

The green T can be enabled or disabled.

5.7.8.1.8 Red Cursor Style

It is possible to pick between thin / middle or thick cursor style.

5.7.8.1.9 Needle Range Type

Non-linear needle means that positive climb numbers are not in the linear scale, but they are wider at weak climb and narrower at very strong climb rate. If you wish to always have the same space between numbers, use the linear scale.

5.7.8.1.10 Colour style – Gauge: Inner

With this dialogue you can change the background colour for the vario gauge (Outer ring) and the background of the information circle within the gauge. You have the following choices:

Gauge	Inner
White	Black (default)
White	White
Black	White
Black	Black

5.7.8.1.11 User msg. Transp.

With this dialogue you can change the transparency of the user messages when they are displayed overlaid on each screen from 0 to 100%. Default is 50%.

5.7.8.1.12 Navbox Transparency

With this dialogue you can change the transparency of the navboxes which are overlaid on each screen from 0 to 100%. Default is 44%.

5.7.8.2 Map

The map orientation can be Track Up or North Up.

Graphic settings of Navboxes from the graphical page can be adjusted in this menu. It is possible to adjust following settings:

- Navboxes background transparency
- Navboxes background colour
- Navboxes border transparency
- Navboxes border colour
- Navboxes title colour
- Navboxes value colour

5.7.8.3 Airspace



Airspaces are not enabled on S8/S80 Club version. To purchase this option please refer to Chapter 3.2.3.

In this dialogue you can define the airspace map presentation. Check the **Show airspace** item to enable airspace displays in navigational modes. If this item is unchecked no airspace will be displayed.

Use **Show only airspace below** to eliminate airspace which is going to be too high for the day. For example, if the forecasted cloud base is to be 1500 m, set this value to 1600 m and your screen will be much more readable.

In the airspace type list, you can specify how each airspace type is displayed. You should define each type of airspace zone separately. First choose an airspace type from the list. You can modify the **Transparency** of the selected type. The **Zoom** value defines to which zoom level this type is going to be visible. The **Colour** and **Width** items specify how the selected airspace zone will be drawn.

All settings listed above can be changed for airspace classes A, B, C, D, E, F and for the following types of airspace:

- Control zone
- Restricted zone
- Prohibited zone
- Danger zone
- Glider sector
- Airway sector
- Transponder Mandatory Zone (TMZ)
- Military zone
- Other zone

5.7.8.4 Waypoints

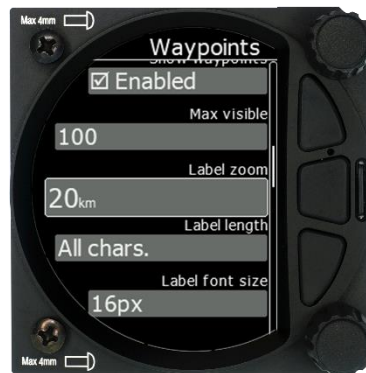

In this dialogue you can define whether waypoints are displayed or not, how many characters are displayed and the size and colour of the label.

5.7.8.4.1 Show Waypoint

Check the dialogue box to enable waypoint labels for the Waypoint and Task Modes.

5.7.8.4.2 Max Visible

This defines for how long waypoints and detailed symbols are displayed. If the maximum number of waypoints on the current screen is more than the defined value only small blue dots will be shown for waypoints and no labels will be drawn.

5.7.8.4.3 Label Zoom

The Label zoom value defines up to which scale of zoom waypoints are visible. 20km means the whole width of the screen represents 20 km.

5.7.8.4.4 Label Length

You can choose to display all the characters in the waypoint name or a maximum of 8, 7, 6, 5, 4, 3, 2, 1 or none.

5.7.8.4.5 Label Font Size

You can choose between 24, 18 or 16 points.

5.7.8.4.6 Label Font Colour

You can choose a font colour from the pallet of 12 colours.

5.7.8.5 Glider and Track



In this dialogue you can choose to show a line to the target and your track line together with the colour from the pallet of 15 colours.

5.7.8.5.1 Show line to target

Check the dialogue box to display a line to the target.

5.7.8.5.2 Line to target

You can choose the colour of the target line from the pallet of 15 colours.

5.7.8.5.3 Show track line

Check the dialogue box to enable a line to the target.

5.7.8.5.4 Track line

You can choose the colour of the track line from the pallet of 15 colours.

5.7.8.6 Thermal Assistant



5.7.8.6.1 Colour Circles By

There are three options for the thermal assistant: Auto Span, MacCready and Average Vario.



The colours in the thermal assistant indicate below average (blue), average (yellow), above average (red) and the strongest point of thermal (white).

- If **Auto Span** is selected then the Thermal Assistant will use the average performance of the last circle to calculate below, average and above average climb and indicate accordingly i.e. red bubbles for strongest lift and blue dots for weakest lift or sink.
- If **MacCready** is selected then the Thermal Assistant will use the current MacCready setting to show rate of climb below, MacCready and above the MacCready setting
- If **Average Vario** is selected then the Thermal Assistant will use the average vario for the flight to show the rate of climb below average vario, average vario and above average vario.

5.7.8.6.2 Switch to Thermal Assistant Mode

When **in circling is selected** the S8x/S10x will change to the Thermal Assistant mode when the glider starts turning in a climb. It can change to the Thermal mode also if SC mode is switched to Vario mode, if setting **SC-VAR. switch** is selected. If the box is disabled the thermal assistant mode can be accessed manually.



The S8x will only detect turning if a GPS or FLARM device is attached. The S8x uses a combination of change of speed, angle of bank and direction change to indicate circling.



The S10x has an internal GPS module.

5.7.8.6.3 Use Active Navigation Data

If this item is checked, all the data relating to navigation will be calculated to either Wpt or Task, depending on which page the thermal mode was switched from.

5.7.8.6.4 For Manual Switching

If you manually switch to thermal mode, all navigation data will be related to the setting you have selected here (**waypoint or task data**)

5.7.8.6.5 Thermal Assistant Ping Method

If the Thermal assistant ping method is enabled the user will hear a PING during circling. When the PING is heard the pilot must expand the circle to centre the thermal. In the settings there are two methods available to trigger the PING: time before thermal maximum and angle before thermal maximum. The ping volume is related to **speech** volume setting.

5.7.8.6.6 Time before Ping

Using this method, the user will hear a PING (different audible signal) the selected number of seconds before maximum of thermal.

5.7.8.6.7 Angle before Ping

Using this method, the user will hear a PING (different audible signal) the selected number of degrees before maximum of thermal.

5.7.8.7 Task



With this dialogue you can change the colour of the task line and turn point zone and modify the zone transparency and Zone line width.

5.7.8.7.1 Show Only Current Zone

It shows only the current active zone on the task.

5.7.8.7.2 Task Colour

You can choose the colour of the task line from a pallet of 15 colours.

5.7.8.7.3 Zone Colour

You can choose the colour of the task line from a pallet of 15 colours.

5.7.8.7.4 Zone Transparency

With this dialogue you can choose the level of the zone transparency from 0 to 100%.

5.7.8.7.5 Zone width

This dialogue defines the line width of the zone with a choice of 10-line widths.

5.7.8.8 FLARM



In this menu you can choose to show FLARM traffic on the map, select target on map only, change glider colours and adjust the FLARM object timeout and graphical settings.

5.7.8.8.1 Traffic on Map

Check the dialogue box to display FLARM objects on the screen.

5.7.8.8.2 Select Target on Map Only

There will be only the selected target on the map.

5.7.8.8.3 Colours

Colours can be set for the following:

- Glider Above Colour
- Glider Below Colour
- Glider Near Colour
- Selected target Colour

5.7.8.8.4 Label Text

On the map it is possible to show additional, related text next to the FLARM object. This option can be set to None, Competition sign, Climb rate and Relative vertical.

5.7.8.8.5 Active Timeout

Adjusts the time a glider symbol remains on the map after it has last been seen by the FLARM.

5.7.8.8.6 Inactive Timeout

Inactive timeout setting sets the time for inactive gliders on the FLARM target list. Inactive gliders are gliders where the FLARM signal has been lost for a period longer than the Active timeout. The targets become inactive and remain only in the FLARM target list for this time.

5.7.8.8.7 Draw Line to Selected Target

Check this option to enable or disable a line drawn to a selected FLARM target.

5.7.8.8.8 Draw History

Select if a trail is to be drawn behind FLARM targets to show where the targets have been.

5.7.8.8.9 Plane Icon size

Use this item to adjust the pixel size of FLARM targets.

5.7.8.9 Modes

Task, Thermal and FLARM modes can be disabled via this menu. Additionally the AHRS page can be disabled here.



For competitions the artificial horizon can be disabled in this menu. When the artificial horizon page is active a BFION event is written to the recorded flight for verification purposes.

5.7.9 Sounds

The sounds option has a sub menu for Equalizer, Vario and FLARM.



5.7.9.1 Equalizer Option

With the lower rotary knob, you can adjust the volume for each frequency. The settings are stored when you exit the screen (via the middle button).



5.7.9.2 Vario Sounds



In this menu the user can change all the parameters for vario sounds.



The volume for Vario, FLARM and Speech can also be adjusted directly via the upper rotary knob whilst in the FLARM, Waypoint and Task Modes.

5.7.9.2.1 Vario Volume

The user can set the default vario volume.

5.7.9.2.2 Sound shape

In this menu, you can choose between following shapes: Sinus, Triangular and Harmonic.

5.7.9.2.3 Vario audio mode:

- **Linear positive:** the sound is interrupted with silence every few milliseconds when the needle is positive; on negative side sound is linear (not interrupted).
- **Linear negative:** inverse function to **Linear positive**.
- **Linear:** the sound is linear and non-interrupted in full scale range.
- **Digital positive:** similar to **Linear positive**, except the way of beeping is sl
- **Digital negative:** inverse function to **Digital positive**.
- **Linear positive only:** the sound is present only at positive values, for negative values there is silence.
- **Digital positive only:** similar function to **Linear positive only**, except the sound is similar to the digital tone.
- **Digital:** similar function to **Linear**, except the sound is similar to the digital tone. The frequency is not changing linearly, but by steps. Sounds like playing a flute.

5.7.9.2.4 SC Audio Mode

SC audio mode has five modes:

- **SC positive:** the sound is interrupted with silence every few milliseconds when the needle is positive; on negative side sound is linear (not interrupted).
- **SC negative:** inverse function to SC positive.
- **SC:** the sound is linear and non-interrupted in full scale range.
- **SC Mixed:** for positive relative values the sound represents relative; for negative relative values the sound represents SC (for that setting it is recommended to set SC needle to relative).
- **Relativ:** the variometer will produce the same sound as defined in Vario audio, except it will follow relative speed values.

5.7.9.2.5 Vario Audio source

Vario audio source is shown when **HAWK** option is activated. You can choose between **HAWK** or TE vario audio source for variometer sound.

5.7.9.2.6 SC Audio source

SC audio source is shown when **HAWK** option is activated. You can choose between **HAWK** or TE vario SC audio source for speed to fly sound.

5.7.9.2.7 Dead band

Dead band setting defines the width of the audio dead band in speed to fly mode. Default value is ± 1 m/s.

5.7.9.2.8 Audio Frequencies

- **Freq at 0%** defines the tone frequency at 0 m/s.
- **Freq at +100%** defines the tone frequency at full + deflection.
- **Freq at -100%** defines the tone frequency at full – deflection.

5.7.9.2.9 Equalization Pre-Sets

We have three options: default LXNAV speaker, flat setting or user defined.



The volume for Vario, FLARM and Speech can also be adjusted directly via the upper rotary knob whilst in the FLARM, Waypoint and Task Modes.

5.7.9.2.10 Voice test

Press this button in order to test quality of voice messages.

5.7.9.3 FLARM Sounds



5.7.9.3.1 FLARM Volume

Adjust the default FLARM volume with the slider.

5.7.9.3.2 FLARM Low Alarm

For distant FLARM targets the S8x/S10x gives a short or long message, just a beep or be turned off (19-25 seconds before possible collision).

5.7.9.3.3 FLARM Important Alarm

For close FLARM targets the S8X can give a short or long message, just a beep or be turned off (14-18 seconds before possible collision).

5.7.9.3.4 FLARM Urgent Alarm:

For very close FLARM targets the S8x/S10x gives a short or long message, just a beep or be turned off (6-8 seconds before possible collision).



The volume for Vario, FLARM and Speech can also be adjusted directly via the upper rotary knob whilst in the FLARM, Waypoint and Task Modes.

For the alarm sound the user has the possibility to select between beep, short message and long message sounds.

Short message is of the form: "Traffic two o'clock"

Long message sounds like: "Traffic two o'clock, two kilometres, two hundred meters above".

5.7.10 Obs. Zones

The default Observation Zones can be configured in this section for all tasks.



The Start, Waypoint and Finish zone can be configured separately although the setup is very similar.



- **Direction:** Options include Start, Previous, Next, Symmetrical or Fixed angle.
- **Angle 12:** is greyed out unless fixed angle is specified in Direction.
- **Line Check Box;** typically used for Start and Finish. If line is checked then Angle 1, Angle 2 and Radius 2 are greyed out.
- **Angle 1:** Sets the angle of the Turn Point Zone.
- **Radius 1:** Sets the radius of the Turn Point Zone.
- **Angle 2:** Sets angle 2 for complex Turn Points and Assigned Area Tasks.
- **Radius 2:** Sets the radius for complex Turn Points and Assigned Area Tasks.
- **Auto Next:** Typically used in racing tasks, this will change the navigation of the S8x/S10x to the next turn point when a single fix is made within the Turn Point Zone.

- **To Near:** if this is checked it will navigate to nearest point of the zone.

5.7.11 Warnings



There are FLARM, Altitude and Airspace warnings.

5.7.11.1 FLARM Warnings

5.7.11.1.1 Enable FLARM Warnings

Warnings can be enabled or disabled in this section.
The warning dismiss time can be set from 0 to 120 seconds.

5.7.11.1.2 Display PCAS Alarms

Check this item to see non-directional traffic on the FLARM screen. Non-directional traffic will be drawn with a dotted circle at the received distance from the aircraft position. The PCAS timeout is setup separately in the next time spin control.

5.7.11.1.3 Display Urgent Alarms

Third level approximately **8 seconds** before predicted collision.

5.7.11.1.4 Display Important Alarms

Second level approximately **13 seconds** before predicted collision.

5.7.11.1.5 Display Low Alarms

First level approximately **18 seconds** before predicted collision.

5.7.11.1.6 Dismiss While Circling

This dismisses FLARM alarms for FLARM targets in the same thermal. FLARM warnings for urgent alerts override this.

5.7.11.1.7 Dismiss Time

If a FLARM warning is dismissed, there will be no FLARM warnings for the number of seconds set in that menu. Once a certain FLARM alarm is set off you can dismiss it for that set amount of second by pressing the lower knob.

5.7.11.2 Altitude Warnings

5.7.11.2.1 Altitude Alarm

This can be set in meters or feet. The S8x/S10x will display a warning before reaching the selected altitude.

5.7.11.2.2 Warn me before

This is related to the Altitude alarm; it can be set from 10 to 500 seconds. The predicted time to reach alarm altitude is calculated from the average vario.

5.7.11.3 Airspace Warnings**5.7.11.3.1 Minutes Off**

Once a warning appears, you can disable it for a specific time in minutes. This time can be set here.

5.7.11.3.2 Seconds before Entry

You can set how many seconds before entering the airspace you would like to get the warning.

5.7.11.3.3 Minimum Altitude Difference

This defines the minimum altitude difference to the zone.

5.7.11.3.4 Minimum Distance

The minimum distance to the airspace before the warning appears can be set here.



5.7.11.3.5 Alert On

Alerts can be defined for specific zones (Class A, B, C, D, E, F, Other, Control, Restricted, Prohibited, Danger, Airway, Glider sector, Transponder and Military).

5.7.11.4 Visual Messages/Warnings



The S8x/S10x will provide the following visual messages/warnings:

- Digital signature failed (it will appear immediately after initial setup)
- Freezing temperature (it is related to the OAT measurement)
- Task started
- Inside zone
- Next zone
- Outside zone
- Airbrakes not locked
- Check landing gear
- Low external battery
- Running on internal battery (if flight recorder is running) 
- Shutting down (if flight recorder is not running and there is no external power) 
- Freezing temperature (if the outside temperature is 1 degrees)
- Altitude warning
- Airspace warning

5.7.11.4.1 Airspace warning visual message

There are 2 different Airspace visual warnings. When you are approaching an airspace an **orange** warning will appear. Once you enter the airspace a **red** warning will appear.



The first row is a name of the airspace. You can terminate a warning for 5 minutes by pressing an upper button or lower button, which will cancel it for today.

H: horizontal distance from the airspace

V: vertical distance from the airspace

INS: means inside

UNK: unknown (data not available)

5.7.11.5 Voice Warnings

The S8x/S10x will trigger the following voice warnings:

Gear Warnings

CHECK GEAR: this warning is triggered 5 minutes after take-off if the landing gear is not wired to any of the inputs of the S8x/S10x.

CHECK LANDING GEAR: during the flight, gear up*, airbrakes opened*.

Airbrakes Warnings

CHECK AIRBRAKES: if you are on the ground, speed 0, gear down*, airbrakes opened*. This warning is repeated every 30 seconds.

WARNING AIRBRAKES, WARNING AIRBRAKES...: during the acceleration, gear down*, airbrakes opened*.

CHECK AIRBRAKES: speed, airbrakes opened*.

Low battery (if the battery is low – see battery chemistry setting).

Stall speed (warning is related to the stall speed set in the menu).

FLARM voice message long: Traffic at: position, distance, vertical distance.

FLARM voice message short: Traffic at: position.

*airbrakes and/or landing gear should be wired to digital inputs!

5.7.12 Units

Use this menu to specify units, UTC time offset and type of ballast input.



- **UTC Offset:** in half or whole hours plus or minus Zulu.
- **System of units:** Metric, English, US.
- **Distance:** Units available; statute miles, nautical miles, kilometres.
- **Altitude:** Units available feet, meters.
- **Temperature:** Units available; degrees centigrade or degrees Fahrenheit.
- **Pressure:** Units available; inches of mercury (inHg), mm of mercury (mmHg), mbar.
- **Speed:** Units available; fpm, m/s, mph, kts, km/h.
- **XC Speed:** Units available; fpm, m/s, mph, kts, km/h.
- **Vertical Speed:** Units available; fpm, m/s, mph, kts, km/h.
- **Wind:** Units available; fpm, m/s, mph, kts, km/h.
- **Weight:** lbs or kg
- **Load:** lb/ft² or kg/m²
- **Longitude/Latitude:** DD.ddddd, DDMM.mmmmm', DDMM'SS.ss'', DD.dddd, DDMM.mmm', DDMM'SS''
- **Ballast:** weight (insert ballast in kg), load (ballast kg/m²), overload (factor of overload).

5.7.13 Hardware

The Hardware setup has a sub menu for Digital inputs, Indicator, Communications, Battery, Remote Stick, Flaps, Bridge.



5.7.13.1 Digital Inputs

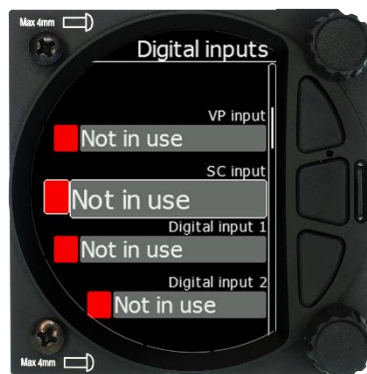

Digital inputs are not enabled on S8/S80 Club version. To purchase this option please refer to Chapter 3.2.3.

5.7.13.1.1 VP Input (Vario Priority)

When this input is activated by grounding the appropriate wire, the unit will change over to Vario immediately. This input wire is set open (not grounded) as a factory default on delivery. This switch has priority over all SC switching methods. This means it will override all other signals for SC and switch unit to vario mode. This input is not wired in standard wiring – it must be wired by the customer.

5.7.13.1.2 SC Switch

The LXNAV S8x/S10x has an input for an external **speed command switch**. Using the external switch, it is possible to manually switch between SC and Vario. Setting the **SC switch** to **ON** mean that closing the switch will cause the instrument to enter SC mode. Setting the SC switch to **OFF** means that closing the switch will select Vario mode. There is a third option by setting SC INPUT to **TASTER** and connecting a push button to the input; each key press will toggle between SC and Vario (mandatory setting for LX Remote, which provides a push button for SC).

5.7.13.1.3 Digital Inputs 1,2,3,4

The LXNAV S8x/S10x has 4 external digital inputs which can be set to indicate the state of the landing gear, airbrakes, canopy switch, tail dolly switch and event input. The wiring is described in Chapter 9.6.1.8.

5.7.13.1.4 Example of Warnings Triggered by the Input:

1. Gear Warnings

CHECK GEAR: this warning is triggered 5 minutes after take-off if the landing gear is not wired to any of the inputs on the S8x/S10x.

CHECK LANDING GEAR: during the flight, gear up, airbrakes opened.

2. Airbrakes Warnings

CHECK AIRBRAKES: if you are on the ground, speed 0, gear down, airbrakes opened. This warning is repeated every 30 seconds.

WARNING AIRBRAKES, WARNING AIRBRAKES...: during the acceleration, gear down*, airbrakes opened.

CHECK AIRBRAKES: speed, airbrakes opened.



Input pins are available on the rear DB15 connector, but they are not wired.



Input is active when it is shortened to ground.

5.7.13.2 Communication Setup

This is used to configure the two ports on the back of the S8x/S10x for connecting to a GPS/FLARM source and to a PDA. Each port can be configured separately.



5.7.13.2.1 Direct link: PDA-GPS link

If your PDA device does not support an automatic switch to DIRECT LINK between the GPS and PDA ports, there is a manual **DIRECT LINK** menu. The user can select between PDA-GPS or BT-GPS.

When **automatic baud rate** is enabled the LXNAV S8x/S10x will automatically search on all speeds to receive valid data on the GPS(FLARM) port. When the S8x/S10x receives a valid NMEA sentence it will lock on that baud rate and stop searching.



PDA-GPS link is normally automatic, but some PDA software requires manual settings.



Connecting the S8x/S10x to the FLARM extension port can lead to insufficient data being sent. Please connect the S8x/S10x to the main FLARM port.

5.7.13.2.2 BT-GPS Link

Allows a PNA device connected via Bluetooth to directly communication with a device which is connected to the GPS/FLARM port (FLARM/Nano).

5.7.13.2.3 PDA Baud Rate

Set the baud rate of the PDA port.

The baud rate on the PDA port must be set to same as it is on the PDA device otherwise S8x/S10x and PDA will not communicate with each other.



The baud rate on PDA must not be lower than the setting on GPS port.

5.7.13.2.4 GPS (S10x-FLARM port) Baud Rate

Set the baud rate of the GPS/FLARM port.



To obtain best performance from the LXNAV S8x/S10x it is recommended that both baud rates are set as high as possible.

5.7.13.2.5 Bluetooth

Toggle this setting to switch ON/OFF the internal Bluetooth module. If the BT module is turned off the power consumption will be lower and the operating time of the internal battery will increase. 



For the Bluetooth operation, the baud rate on GPS must not be lower than 9600bps.

5.7.13.2.6 Send Declaration to GPS Port

This will automatically send a declaration to an external Flarm module.

5.7.13.2.7 NMEA output

NMEA output on PDA port and on BT can be enabled or disabled. If you are not using a PDA port this setting should be disabled to obtain better performance.



Before using Bluetooth, a Bluetooth antenna must be connected to the unit.



The Bluetooth password is 1234 or 0000.
This Bluetooth is compatible with iOS and Android.

5.7.13.2.8 Beeps Controlled by PDA

If a PDA is connected to the S8x/10x, the PDA can send a beep command to the S8x. If this feature is enabled the S8x/10x will beep on request from the PDA.

5.7.13.2.9 External Target

If this item is checked the unit will accept target information received by the PDA, BT or GPS ports. The user will see information on the screen that a new target has been received. The user can accept or ignore the target.

5.7.13.3 Battery Setup

S10x units have 2 options listed:

- External battery
- Internal battery 



5.7.13.3.1 External Battery Chemistry

The user must select the battery from the battery list to obtain the proper voltage measurement.

Batteries used in gliders today are not only the old-style **lead acid battery** but also **Lithium Ion (LiIon)** and **Lithium Iron Phosphate (LiFePo)** are available.

Each battery type has a different power delivery curve and it is now possible to configure the Low and High Battery warnings.



Select battery from list gives you a drop-down list with the suggested battery settings for Full Voltage, Low Battery Voltage and Empty Voltage as pre-sets. Selecting one of these will set the values in the following boxes.



Alternatively, you can manually change the Full Voltage, Low Battery Voltage and Empty Voltage if your battery type is not listed. Those settings will influence the battery level icon and low battery warning.

5.7.13.3.2 Internal Battery

S10x units have also a built-in internal battery where you can check the health and settings of this battery.



5.7.13.3.3 Health of the Battery

This shows the health of the internal battery and its charge level. Charge level while connected to external power will indicate 100% when charging, even if battery is not full. If the battery is full it will display "FULL".



5.7.13.3.4 Settings of the Internal Battery



The following values can be set:

- Preserve battery = charger will not be activated until the battery drains below **75%**.
- Charge to full = if it is not checked, the battery will be charged up to approximately **90%** (when charging current drops below 0.45A).
- Charger mode = can be set to **ON / OFF** or **automatic**.

Automatic mode will stop charging when the charging current drops below 10mA. Then the charge status will indicate **FULL**. If preserve battery is enabled, charging will take place only when the battery is below 75% and will charge to full or 90%, depends on setting.



The internal battery will not supply power to any peripheral devices such as remote stick, FLARM, PDA...



S10x will charge internal battery only when external power is present and the unit is powered on.

5.7.13.3.5 Battery Calibration

Sometimes internal battery needs to be self-calibrated. New calibration of the battery can be done with full discharge cycle.

To start the process, charge the battery to FULL. When you see FULL, remove external power, and leave it running until internal battery is empty.

If battery is not calibrated the indication of the SOC % might be wrong. Value however is always correct at the FULL charge state in every case.

5.7.13.4 Remote Stick (NEW)

The remote stick is also connected to the CAN bus which is the main wiring of the S8x/S10x. The device must be registered in case of a two-seat device as it is possible to have two remote sticks; one registered to the main device and the other one to the second seat device.

Registering the remote stick can be carried out in the following way:

Press any button on the remote stick – the S8x/S10x will detect the presence of the remote stick on the CAN BUS.

Go to Setup->Hardware->Remote stick.

To confirm the remote stick, you must press the OK button on the remote stick.

The process is similar for the second remote for the S8xD repeater unit. Be sure that at the time of registering repeater unit, front unit is not in Register mode, otherwise both units will listen to the same remote stick.



Whilst the remote stick uses a different type of communication than the Sxxx, the user must specify for what purpose remote stick will be used when ordering one. In case of Sxxx instruments, an adapter named Remote CAN will be included. On one side it is connected to the CAN bus via a DB9 connector and on the other side to appropriate wires of the remote stick. Follow the colour marks on the pring contacts.



The Can bus is always under power, consequently the remote stick is also under power. After the flight disconnect the batteries or turn off the master switch to prevent discharging the batteries.



The remote stick is only recognized if the system is under external 12V power. It will not work if the S10/S100 is running on the internal battery only.

5.7.13.5 Flaps

When a flap sensor is installed, use this menu to set the flaps position. **Toggle SC/Vario at** option allows you to select when (depending on flap position) the instrument will switch between SC and vario mode. Use the page selector to select the desired flap position. Press SET to set the position. Repeat this procedure for all flap positions.



When all flap positions are set, a green dot will be displayed with current flap position. If flap labels are not set yet, press **EDIT** to name the labels. Flap labels must be entered with increasing speed range. It is recommended that flaps labels are set together with the speed range in the Polar and Glider setup. It is also possible to toggle between cruise and climb mode using the flap sensor.



5.7.13.6 AHRS

Once AHRS option or **HAWK** option is activated as described in chapter 9.5.7, use this menu to calibrate AHRS for installation errors.

Place your glider in levelled position and select **Level**, it will set system pitch offset and current pitch will be set to 0°.

You can also modify **User pitch offset**.

Reset off. Button will reset system pitch offset and user pitch offset to zero (Factory default).

Align gyros will adjust drift of gyroscopes, which solve the problem of small pitch and roll offset during flight.

Reset gyros will set back to factory defaults all user gyro alignments.



During flight user pitch offset can be adjusted via the lower rotary knob.

In this menu AHRS can also be **Locked by Password**.



The **AHRS locked** option may be used by contest organizers. They can lock or unlock an AHRS with their own password.

If AHRS is Locked by Password and the password has been forgotten, please use the password **23519**.

5.7.13.7 CAN Bridge

The CAN Bridge is an external device which is sold separately and is used to output NMEA data or to connect a radio or transponder to the system.



Refer to the installation manual for details on the wiring of the CAN Bridge.

Once a CAN bridge is plugged in to the CAN BUS, Bridge Sxxxxxx will appear in the Hardware menu.



First, you must define the functionality. The dialogue will change based on what you select and will display relevant items.

5.7.13.7.1 NMEA Output



NMEA output is used to transmit NMEA sentences. You can select desired NMEA sentences and define the baud rate at which they will be transmitted.

5.7.13.7.2 Radio Bridge

The Radio Bridge is used to operate a radio through the main display unit. First the type of connected radio must be selected. For the list of supported devices please refer to CAN Bridge installation manual found on www.lxnav.com.



Due to Becker AR6201 not supporting RS-232 connections it is not yet supported.

Selecting **Config radio** will open the radio setup menu. In this menu you can select **Show target warnings**. This will trigger warnings generated from the device (example: radio is too hot). Here you can also setup **active** and **standby frequency**, **volume**, **squelch volume** and **VOX volume**.

If your airport has a frequency, it will be automatically selected as standby frequency on the radio once the airport is selected. Auto select target frequency must be selected for this to work.

5.7.13.7.3 XPDR Bridge

The XPDR Bridge can operate the transponder via the main unit. You can set the ICAO Identity in the XPDR Setup menu which is opened by clicking **Config XPDR**. It can also show target warnings from the transponder. For the list of supported devices please refer to CAN Bridge installation manual found on www.lxnav.com.

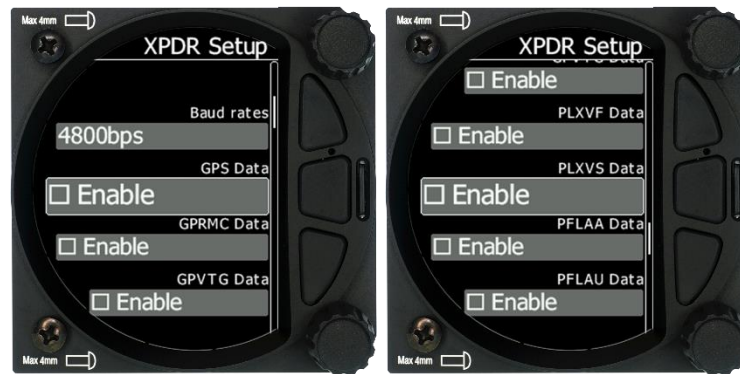

5.7.13.8 FLARM

If a FLARM or PowerFLARM is connected to the system its information, configuration and aircraft configuration can be seen or configured in this menu.



5.7.13.8.1 Info

Here you can see all information about the external FLARM/PowerFLARM device. Available information is:

- Hardware
- Firmware
- Flarm ID
- Serial Number
- Obstacle database
- Obstacle date

5.7.13.8.2 Config

The FLARM configuration such as **FLARM/PCAS** and **ADSB horizontal and vertical** range can be set here. **Mode C/Do not track mode** and **Stealth mode** can be enabled or disabled. **Stealth mode meaning** – if enabled, other FLARM units will not receive altitude and vario information concerning your glider (only a dot will appear on their instruments). For collision warnings this mode has no influence. **Do not track** enabled will not allow an object to be seen on the OGN.

5.7.13.8.3 Aircraft Config

The **Aircraft type** such as glider / Tow plane / Helicopter etc... can be set here. The **ICAO address** is the code which has to be configured in the config file if a transponder is present. If that code is not set, a transponder in the cockpit will be seen as a FLARM object all the time.

5.7.13.8.4 Flight Recorder

The FLARM's flight recorder settings can be modified in this menu.

5.7.13.8.5 Flarm error codes

Error codes are displayed on Sxxx screen, flarm displays or you can read it on flarm generated files on flarm's SD card.

- 11 = Firmware expired (requires valid GPS information, i.e. will not be available in the first minute or so after power-on)
- 12 = Firmware update error
- 21 = Power (e.g. voltage < 8V)
- 22 = UI error
- 23 = Audio error
- 24 = ADC error
- 25 = SD card error
- 26 = USB error
- 27 = LED error
- 28 = EEPROM error
- 29 = General hardware error
- 2A = Transponder receiver Mode-C/S/ADS-B unserviceable
- 2B = EEPROM error
- 2C = GPIO error
- 31 = GPS communication
- 32 = Configuration of GPS module
- 33 = GPS antenna
- 41 = RF communication
- 42 = Another FLARM device with the same Radio ID is being received. Alarms are suppressed for the applicable device.
- 43 = Wrong ICAO 24-bit address or radio ID
- 51 = Communication
- 61 = Flash memory
- 71 = Pressure sensor
- 81 = Obstacle database (e.g. incorrect file type)
- 82 = Obstacle database expired.
- 91 = Flight recorder
- 93 = Engine-noise recording not possible
- A1 = Configuration error, e.g. while reading flarmcfg.txt from SD/USB.
- B1 = Invalid obstacle database license (e.g. wrong serial number)
- B2 = Invalid IGC feature license
- B3 = Invalid AUD feature license
- B4 = Invalid ENL feature license
- B5 = Invalid RFB feature license
- B6 = Invalid TIS feature license
- 100 = Generic error
- 101 = Flash File System error
- 110 = Failure updating firmware of external display
- 120 = Device is operated outside designated region. The device does not work.
- F1 = Other

5.7.14 Polar and Glider

5.7.14.1 Polar

The Polar and Glider section allows you to load and edit a set of parameters for your glider's polar. You can select from a pre-defined list of most common gliders or create your own polar.



Select Glider from List: presents you with an alphabetical list of all the common gliders and associated polar data. All glider data will be copied from the chosen polar. Verify that the best glide ratio and minimum sink rate are displayed. To see whether the polar data matches your glider's performance, review the MacCready Setting Menu where you can verify the values.



You can modify the polar by changing coefficients **a**, **b** and **c**. A polar is defined as a quadratic equation with the parameters a, b, and c.

Use the SeeYou program (Tools->Polar) to calculate coefficients **a**, **b** and **c** for a given glider's polar. The program requires three sink points entered at selected speeds (e.g.: 100 km/h, 130 km/h, and 150 km/h). The program will calculate the values of **a**, **b** and **c**, which should be noted and entered into the LXNAV S8x/S10x.

- **Class:** Options for Touring, Ultralight, World, Twin-seater, Club, 18-meter, 15-meter, Open, Standard and Unknown are available.
- **A, b, c:** Options can be adjusted or entered for a non-listed glider.
- **Reference load** (wing loading) value represents the value at which the polar was measured.
- **Reference weight** corresponds to the weight value at which the polar was measured.
- **Maximum take-off weight** is the maximum take-off weight allowed for the glider. It is not used in the calculation; it is just a reminder to the pilot of the maximum take-off weight. **Empty weight** is weight of the glider without the pilot and ballast.
- **Pilot weight** is the weight of the pilot with parachute and baggage.

- **Co Pilot Weight** is the weight of the co-pilot with parachute and baggage.



$$overload = \frac{Empty.glider.weight + Pilot.weight + Water.ballast}{Reference.glider.weight}$$

In case of a two-seater configuration both users have possibilities to change parameters. The last change performed is synchronized into both instruments.

5.7.14.2 Speeds

The user can set the following speeds:

- Stall speed (VS0)
- Stall speed (VS1)
- Approach speed (Vapp)
- Best climb (Vec)
- Max flaps (Vfe)
- Manoeuvre speed (Va)
- Max speed (Vne)

These speeds will be used as warnings such as stall speed

5.7.14.3 Flaps

For setting up flaps please refer to Chapter 5.7.13.5 for more details.

5.7.15 Profiles

In this menu, the pilot can save his own settings in a profile. Different profiles are useful if more than one pilot is flying the same glider, or if the glider has a variable wing configuration (15m, 18m). All the S8x/S10x settings are saved in each individual profile (glider information, pilot information, user interface...).



With the lower rotary knob, a pilot can scroll between different profiles that are stored within the internal storage of the S vario. Please note that the profiles are not stored on the SD card.

When you select the profile pressing the lower rotary button will cause a sub menu to appear with the following options:

- **Edit** (edit name of the profile)
- **Active** (make that profile active)
- **Lock** (lock that profile. All later changes on the S vario will not be stored to the profile which is useful to protect a profile from changes in a club or syndicate environment)
- **New** (create new profile. You have the option to copy an existing selected profile or create a new factory default profile)
- **Save to SD** (copy the profile from the internal storage to the SD card)
- **Cancel** (do nothing and exit from that menu)
- **Delete** (delete selected profile) At power on the profile selection menu will appear. A user can select between all the available profiles stored within the S vario.



Settings cannot be saved into the DEFAULT profile, therefore you have to create your own profile.



Character (A) means currently active profile.

5.7.16 Password

There are several system passwords which run specific procedures as listed below:



5.7.16.1 List of Password Functions

DELETE WHOLE LOGBOOK	99999
RESET TO FACTORY DEFAULT	00666
AHRS LICENSE ACTIVATION / DEACTIVATION	30000
AHRS REACTIVATE	23519
AUTO ZERO	01043
REPORT TO SD CARD	00111
UPDATE FIRMWARE	89891
DELETE AHRS PASSWORD	23519
START CAN LOGGER	43001
FORMAT INTERNAL FILESYSTEM (All data will be lost)	32233

5.7.17 Admin Mode

In this menu a pilot can lock the unit and protect the settings with a password. If admin mode is selected and a password applied, the settings on the unit will be locked and are not able to be changed. This function is very useful in a club glider where not all the pilots are experienced enough to setup the unit. In this case the designated administrator can lock the unit with a password. The unit can be unlocked anytime with the same password. **Do not** forget the admin password. If it is forgotten the only way to recover is to enter password **00666** which resets the whole instrument to factory default and all settings will be lost.

5.7.18 About

In the about page information about the display platform and the sensor box can be viewed. The user can view the following details:

- IGC serial number 
- Indicator version A and B,
- Sensor box version A and B.



6 Variometer and Altimeter

All signals from the pneumatic sensors (altitude, speed) are derived from high quality pressure sensors, which mean that no flask is necessary. The vario signal is derived from the altitude signal. All signals are temperature and altitude compensated. The colour display shows the vario information as well as many other parameters.

The display is user configurable. The Variometer can be configured to show:

- **Range** 5, 10 and 2.5 m/s or 10, 20 and 5 kts.
- **Time constants** 0.1 s to 5 s, in addition there are 4 settings for electronic processing for the vario signal.
- **Netto** shows the air mass lift and sink.
- **Relative** shows the lift or sink that would be achieved if the glider was circling at thermaling speed.

There are two ways by which the vario indications can be corrected for total energy. Electronic TE compensation is based on speed changes with time and pneumatic compensation with a TE probe. The quality of the TE compensation depends entirely on the location, size and dimension of the TE tube. The installation must be leak-proof.



If an electronic TE compensation is selected the TE (P_{st}) port should be connected to a good static pressure source. If pneumatic compensation is selected the TE (P_{st}) port should be connected to the TE probe.

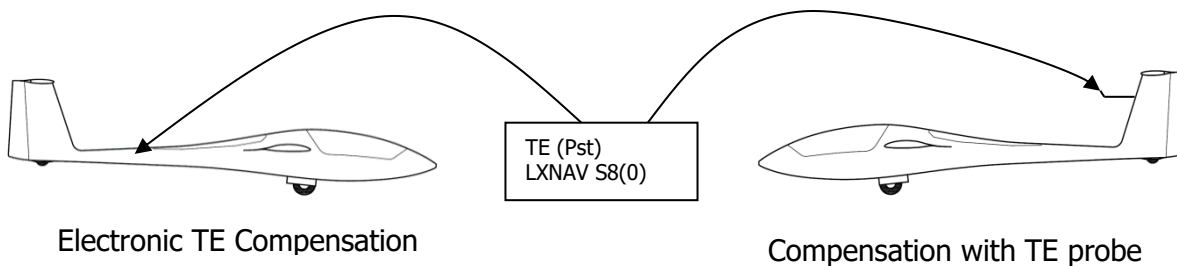

6.1 Altimeter

The altimeter of the LXNAV S8x/S10X is temperature compensated from -20°C up to + 60°C. The altimeter is calibrated up to 20000 m.

6.2 Speed Command

Speed command flying based on the MacCready theory is a very useful tool to optimize cross-country speed. When the instrument changes to speed command mode the audio will change and become a director informing the pilot whether he is flying too fast or too slow. To reduce confusion between vario and speed command audio some special features are incorporated:

- Continuous audio signal and other kinds of signals can be chosen. For details see setup.
- No audio at correct speed (dead band).

7 HAWK

7.1 Introduction

HAWK system was developed by Prof. Heinrich Meyr¹ and Peng Huang² in cooperation with LXNAV. It features a completely new approach towards measuring the three-dimensional wind vector.

A conventional vario measures the vertical movement of the glider (vario) based on an energy conservation principle. This value can be assigned to the red needle of the LX instrument. In perfectly smooth air, the change of the vertical kinetic energy (velocity) is compensated by an equal amount of potential energy (altitude). A total energy compensated (TEK) vario works well under the condition of constant horizontal velocity. However, any change of the horizontal velocity (horizontal wind gust) is interpreted by the TEK vario as a change of the vertical velocity (kinetic energy), thus causing the well-known false reading of the TEK vario.

The HAWK does not measure the vertical movement of the glider. It measures the air mass movement in three dimensions. The climb rate of the glider ("HAWK vario") is derived by subtracting the ideal sink rate given by the circle polar from the vertical climb rate of the air mass. It is, therefore, crucial to understand that the "HAWK vario" shows the potential climb rate of the glider. This is the climb rate of the glider achievable under ideal conditions. "HAWK vario" value is shown by the blue needle of the instrument in thermaling mode.

If the pilot uses the two-needle approach the red and the blue needle are normally close. If they differ substantially, it hints that the pilot flies with a large sideslip angle causing additional drag and sink. Changing the yaw string pointing slightly outside makes the red approach the blue needle: the real climb rate approaches the potential climb rate. This will be discussed in detail in section 7.3 and 7.4.

In cruise mode, the blue HAWK needle should be assigned to "netto" or "relative". At all speed the HAWK needle then shows the climb rate of the air mass ("netto"). If "relative" is assigned to the needle, it shows the minimum sink rate subtracted from the "netto".

The horizontal dimensions of the air mass movement show the wind. The wind is live wind. In mountain flying it is of crucial importance to have the wind indication following the rapid changes of the wind in real time. Today's wind estimation algorithms deliver only mean values with average times in the range of minutes.

The unique differentiator of HAWK is

- It delivers the horizontal wind and the vertical air mass movement (vario) in real time
- No false climb indication due to horizontal gusts in fast cruise mode. If HAWK signals show a thermal there is a thermal with high probability
- A few seconds earlier indication when approaching a thermal than the TEK vario
- No false reading due to horizontal gusts in turbulent thermals
- No compensation required

¹RWTH Aachen University and Barkhausen Institut, Dresden, Germany.

²Vodafone Chair Mobile Communications Systems, Technische Universität Dresden, Germany.

7.2 Wind Model

The HAWK requires a mathematical model of the three-dimensional wind vector. Figure below shows wind field estimated by HAWK. The wind vector $\mathbf{d}(x, y, z; t)$ depends on the three

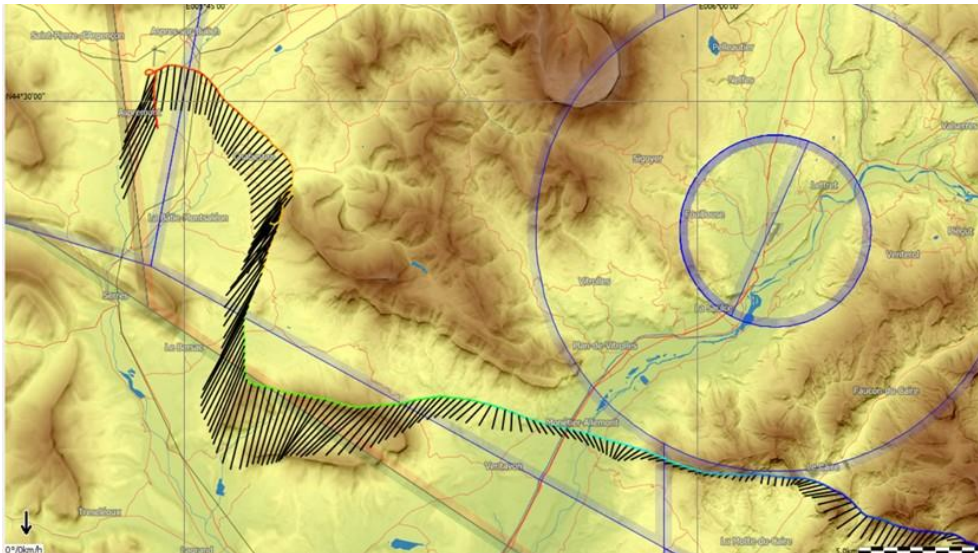

Wind field estimated by HAWK.

spatial coordinates (x, y, z) and the time t . The wind field is described by very complex mathematical equations. For our purposes, it is sufficient to use a greatly simplified model. We assume that the wind vector comprises two elements: a slowly varying component and a rapidly varying random disturbance. Next figure shows that the more turbulent the air mass, the larger the random increment is. The three wind components are assumed to be independent of each other. All three obey the same mathematical law. The perspective representation of a three-dimensional vector on the display does not make sense for gliders. Glider pilots are used to reading the vertical component of the vector on the Vario and interpreting the x-y components as “wind”.

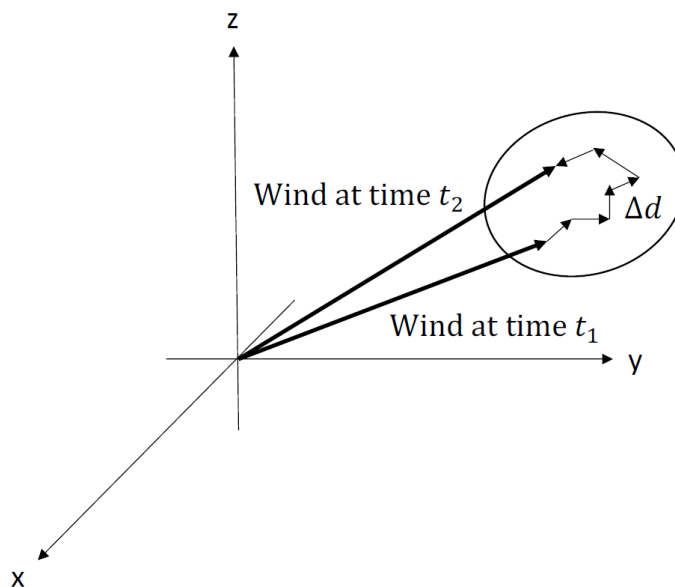

Time behaviour of the wind field $d(x, y, z;t)$.

For an intuitive understanding of the model, we limit ourselves to the vertical component. We are used to interpreting the rate of the variometer by the movements of the pointer. For this reason, we look at the increment over a time interval of 1 second.

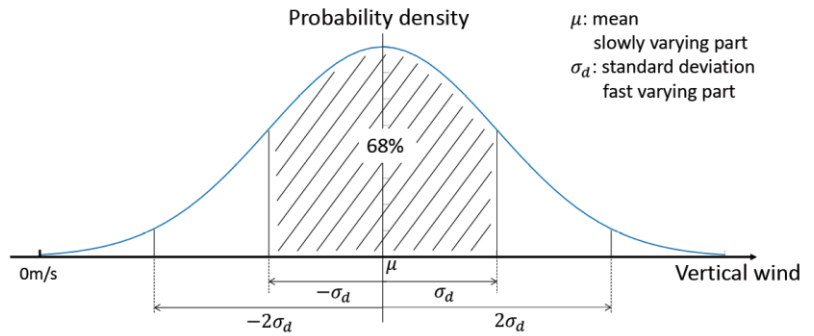
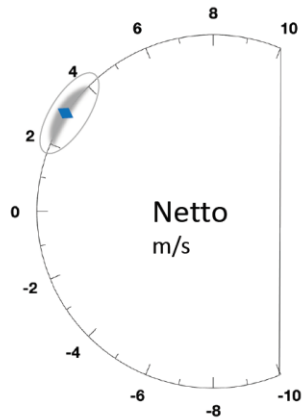

In picture above, the variometer shows a value of 3m/s. This value corresponds to the slowly changing part of the model. The rapidly changing, random part corresponds to the fluctuations of the pointer around the mean. The pointer fluctuations are Gauss- distributed, see right picture above. The Standard Deviation parameter, σ_d determines how likely an increment is around the mean of 3 m/s. For example, $\sigma_d = 1$ m/s states that 68% of all changes are in an interval of 1 m/s. The value $\sigma_d = 0.1$ corresponds to a very quiet air mass. Most changes will be at an interval of 0.1 m/s.

The true model parameter σ_d is of course unknown to the instrument. The key question is, therefore, how do we select the corresponding parameter in the S10/100?

The only way to do this is to use the same data sensor signals for different values of wind variance and study the behaviour of the vario. We can do this because we record all sensor signals at 100Hz using the special logging function in S10/100.

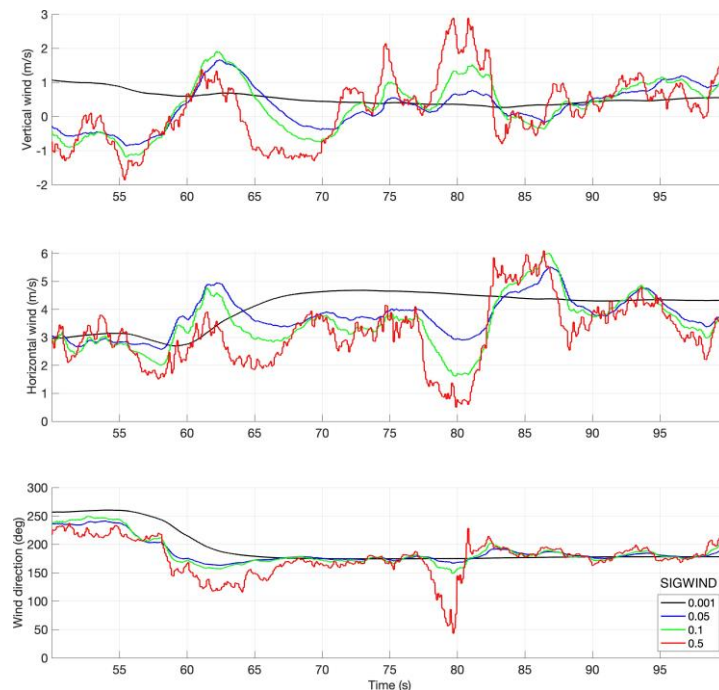

Behaviour of the air mass movement for various values of wind variance = (0.001, 0.05, 0.1, 0.5) in a typical flight.

Let us choose a value wind variance = 0.1, which looks plausible. Qualitatively, if we select a very small value of wind variance = 0.001 the algorithm will average the estimate since it considers large deviations Δd as highly unlikely and suppresses them. We next consider the opposite case and select a much larger value wind variance = 0.5. The algorithm reacts quickly to any disturbance. We will observe a nervous reading of the needle in the instrument. Picture above shows a segment of a typical flight.

We observe that the most likely values are around wind variance = 0.1. For wind variance = 0.5 the random fluctuations are larger. The values smaller than 0.05 are too small since they suppress important details of the time behaviour. It appears that the values in the interval of 0.05-0.2 are the preferred ones. But this is a qualitative and subjective observation not based on a rigorous mathematical optimization.

In summary, the selection of the wind parameter, Wind variance, is not very sensitive. It leaves room for personal preferences of the pilot, as vario needle filter for the TEK vario. During tests most pilots have chosen a value between 0.05-0.2.

7.3 The potential climb rate

The "HAWK vario" is a derived quantity from the primary information of the algorithm. It is computed by subtracting the ideal circular polar sink rate from the estimated vertical air mass movement ("netto"). The "HAWK vario" equals the **potential climb rate** of the glider. By this we understand the maximum achievable climb rate of the glider.



The two-needle approach helps to optimize the thermaling performance by comparing the real climb rate of the red needle ("TEK vario") to the potential climb rate of the blue needle ("Hawk vario"). For example, if the pilot flies with a large sideslip angle, the difference between the two needles can be minimized by flying with a smaller sideslip angle. The red needle will approach the blue needle: the real climb rate has become larger.

7.4 The Aerodynamic Model

The HAWK uses the polar diagram of the glider and a sideslip coefficient to compute error signals. The sideslip coefficient is calculated from the aerodynamic properties of the glider. These parameters are internal variables of the HAWK and cannot be modified by the user.

The sideslip angle has a strong impact on the performance of the glider. The string is a simple but key instrument for the pilot to keep the sideslip small. A sideslip causes an additional drag which is particularly annoying during circling since it largely increases the sink rate. The increase of the sink rate is reinforced when the pilot flies with a large roll angle (circle polar). During circling most pilots fly with the string slightly outside. The HAWK calculates the sideslip angle. The large majority of pilots fly with small sideslip angles of less than 4 degrees.

Before we demonstrate the effect by an example, we recall some properties of the conventional TEK vario. Assuming a smooth thermal, the TEK vario measures the actual climb rate of the

glider, not the air mass movement. If we fly with a large side slip, the glider's climb rate is smaller than flying with zero sideslip in the same thermal. The Netto TEK and the Relative TEK vario are derived quantities by adding fixed constants to Vario TEK. These constants are calculated from the polar diagram in still air.

The HAWK operates entirely differently: it estimates the climb rate of the air mass (Netto HAWK) from the vertical wind triangle. The sum of vertical wind (climb rate of the air mass) and vertical true airspeed (sink rate) equals the vertical "ground" speed (actual climb rate of the glider). The vertical ground speed is the actual climb rate of the glider. More details can be found in the paper of the Segelfliegen Magazin "Wissen, woher der Wind weht" which can be downloaded from our webpage.

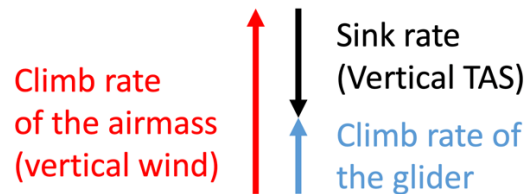
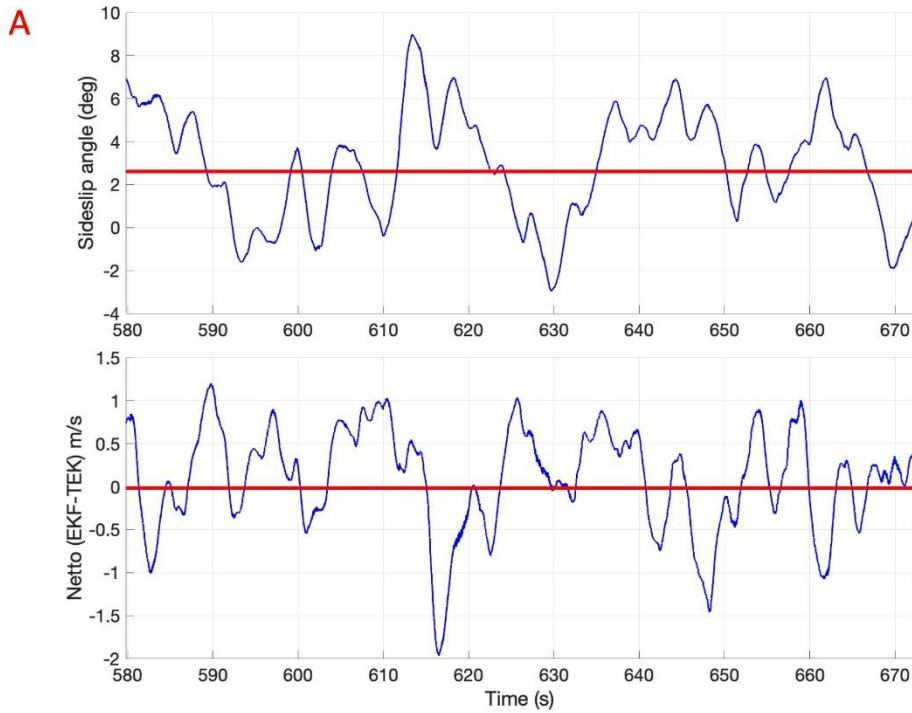

Fig Vertical wind triangle

An example greatly helps to illustrate the details. The table below summarizes the velocities during three circling segments of the same flight by an ASG 32. The segment A has been taken during right circling with a roll angle of about 40 degrees. In the picture on the next page the average sideslip angle is around 2.7 degrees. The glider climbs with 1.4 m/s (2nd row in Table). The Netto HAWK equals 2.7 m/s. The sink rate HAWK is estimated as -1.0 m/s. According to the vertical wind triangle, the summation of the Netto HAWK and the sink rate HAWK equals 1.7 m/s. Due to the short-term averaging, the difference is not exactly 1.4 m/s as the actual climb rate. We next compare this to the readings of the TEK vario. The average Netto values of TEK and HAWK over the segment A are the same. In the 6th row we show the sink rate computed from the circle polar using the roll angle computed in the artificial horizon of the HAWK.

Average	A (580 - 670s)	B (2033 - 2106s)	C (2106 - 2194s)
Sideslip angle	2.7 deg	-12 deg	-6.2 deg
Climb rate of glider	1.4m/s	1.8 m/s	2.1 m/s
Netto (HAWK)	2.7 m/s	4.4 m/s	4.5 m/s
Sink rate (HAWK)	-1.0 m/s	-2.9 m/s	-2.4 m/s
Netto (TEK)	2.7 m/s	2.6 m/s	3.2 m/s
Sink rate (circle polar)	-1.0 m/s	-1.1 m/s	-1.3 m/s
Netto HAWK – Netto TEK	0 m/s	1.8 m/s	1.3m/s
Vario (HAWK)	1.7 m/s	3.3 m/s	3.2 m/s
Vario (TEK)	1.8 m/s	1.9 m/s	2.4 m/s



Segment A: Sideslip angle and Netto difference.

In a nutshell: The agreement between TEK and HAWK vario during stationary circling of the glider is particularly good. This changes completely when we analyse segment B and C. Picture below shows two segments B and C of the same flight of the ASG 32. They are taken during left circling with a roll angle of 45 degrees. In segment B the sideslip angle has been intentionally increased by the pilot to a large value of -12 degrees.

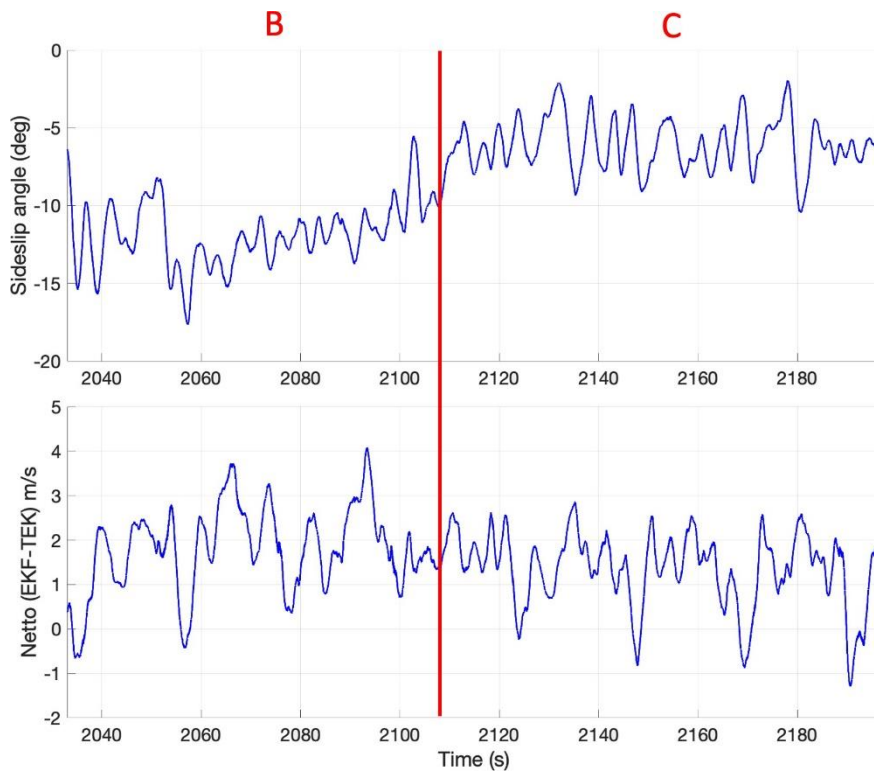

Segment B and C: Sideslip angle and Netto difference.

In segment C the sideslip angle is decreased to -6.2 degrees. The string is slightly pointing outside, as usual.

We first analyse segment B where the sideslip angle is -12 degrees. The glider climbs with 1.8 m/s (2nd row in Table 1). The vertical wind (Netto HAWK) equals 4.4 m/s. The Vertical TAS (sink rate) is estimated as -2.9m/s. Based on the vertical wind triangle, the summation of these two values equals 1.5 m/s. Due to the short-term averaging the difference is not exactly the climb rate 1.8 m/s. We next compare the Netto HAWK to the readings of the TEK vario. The most striking result is that the Netto values of TEK and HAWK differ by 1.8 m/s because the glider suffers from a large sink rate due to the large sideslip. The Netto TEK is derived by adding a fixed constant to Vario TEK. This constant does not consider the impact of circling and sideslip.

We next analyse segment C. The glider climbs with 2.1 m/s faster than in the segment B. This is expected due to a smaller sink rate in a smaller sideslip. The sink rate HAWK is decreased to -2.4 m/s. The Netto TEK increases from 2.6 m/s (B) to 3.2 m/s (C). This increment is due to less drag in the segment C. There is still a large difference of 1.3 m/s (C) between the Netto values of TEK and the HAWK, but the difference is less than in the segment B. The sink rate of the HAWK decreases from 2.9 m/s to 2.4 m/s. The difference between the sink rate HAWK and the circle polar sink rate is 1.1 m/s. It equals the loss of the climbing rate due to a sideslip caused drag.

In a few cases it has been reported that the average HAWK vario in weak thermal shows too large climb rates of up to 0.5 m/s. The analysis of the recorded flight data in the lab showed that the sink rate was larger than the theoretical value computed by the circular polar. The side slip angle was small. The difference could therefore not be attributed to the side slip angle. The additional drag can be caused by a number of reasons. A single cause-effect logical chain could not be identified. Possible reasons are wrong polar and glider data, malfunctioning of the pressure system, inaccurate time mismatched static and total pressure signals etc.

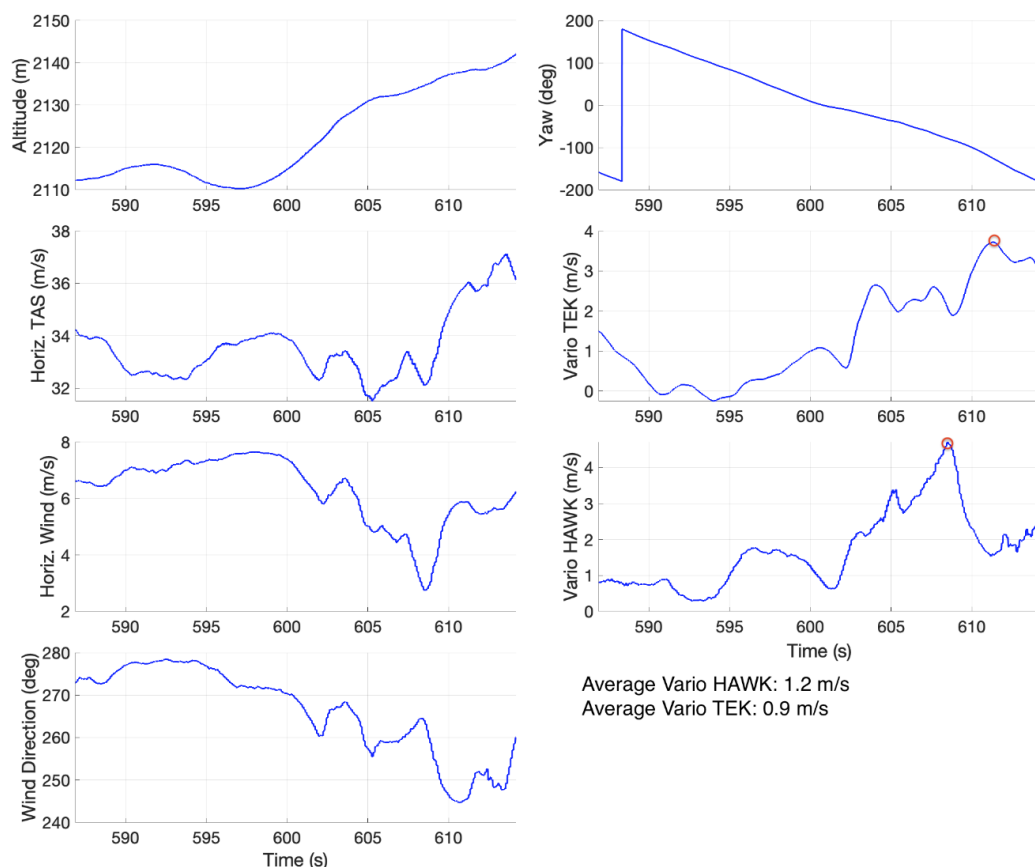

TEK and HAWK vario during one circle

7.5 Dynamic behaviour

Dynamic behaviour of the TEK vario and the HAWK vario is different. The vario HAWK and TEK are shown in the first figure above. The average climb rate of the two varios is shown in the bottom right. They are comparable taking into account the short averaging interval. As expected, the behaviour as a function of time is markedly different. The signal of the TEK vario depends on the averaging time constant chosen by the pilot and on the false signals caused by horizontal gusts. The HAWK vario signal depends on the wind parameter SIGWIND and internal parameters. The resemblance of the vario signals increases in smooth thermals.

Thermal assistant: It is obvious that the thermal assistant shows a different pattern. Note that the maximum of the HAWK vario in the above example occurs 4 sec earlier.

7.6 HAWK system activation

In order to run **HAWK** system, a **HAWK** option must be purchased. Please contact your local dealer or LXNAV directly to get your **HAWK** option. Once you receive option file from us refer to Chapter 9.5.7 for installation procedure.



HAWK system can also be tested free of charge for a period of 31days. Please visit www.lxnav.com to obtain you demo option for HAWK system.

7.7 Setup parameters

7.7.1 Netto Vario

The HAWK estimates the vertical air mass movement. For a conventional TEK variometer the term "Netto" is understood as the vertical air mass movement. However, the TEK variometer only approximates the vertical air mass movement by adding the sink rate to the measured TEK Vario value. But for practical purposes, the difference between the "Netto" and the real vertical air mass movement is small. For this reason, we also use the term "Netto" for HAWK.

7.7.2 Vario

For the compensated TEK variometer the (primary) output TEK Vario is the actual climb/sink rate of the glider. The HAWK computes the value by subtracting from the vertical component of the air mass movement "Netto" the polar sink rate (TAS, roll angle). Notice that the sink rate is computed using the estimated roll angle in the circle polar computation.

7.7.3 Relative Vario (Super netto)

In the speed to fly mode the pilot wants to know the potential climb rate of a thermal. This value is the vertical climb rate "Netto" of the HAWK. If one subtracts from "Netto" the constant minimum sink rate this is the "Relative" output.

For the TEK Variometer the "Relative" must be computed from the primary source TEK Vario by adding the current sink rate minus the minimum sink rate. All computations are summarized in the following table.

	Classical vario calculation	HAWK calculation
Netto	TEK_Vario+sink_rate(IAS,roll_angle)	Netto
Relative (Super netto)	TEK_Vario+sink_rate(IAS,roll_angle)-min_sink_rate	Netto-min_sink_rate
Vario	TEK Vario	Netto-sink_rate(IAS,roll_angle)

7.7.4 Levelling AHRS



It is absolutely necessary that the plane is aligned with the longitudinal axis defined in the manual of the glider. Any misalignment leads to systematic errors in the HAWK algorithm.



HAWK algorithm can compensate $\pm 10^\circ$ of the pitch offset. If the unit is installed in the glider with more offset, HAWK algorithm might not work properly.

If installed device is not perfectly aligned with glider longitudinal axis it is essential to do a pitch alignment, which can be done in Setup>Hardware>AHRS menu. Put glider into zero degrees pitch position, usually this is a weighting position and press Level button in this menu. Device will perform auto-levelling procedure and system pitch offset will be calculated. See also chapter 5.7.13.6 for more details.

7.7.5 HAWK Parameters

HAWK parameters can be setup in via Setup>Vario Parameters menu. See chapter 5.7.3 for details. Following parameters can be set there:

- Wind variance SIGWIND: range 0.005 to 0.5 (recommended value: 0.11). See chapter 5.7.3.15.
- Horizontal wind average: range 0.1 to 100sec (recommended value: 30sec). See chapter 5.7.3.16.
- Vertical wind average: range 0.1 to 50 sec (recommended value: 10sec). See chapter 5.7.3.17.

7.7.6 Graphical display

It is recommended to set following display options, when using HAWK system.

In Setup>Graphics>Indicator set both needles to be visible. Set blue needle for HAWK values and red needle for TEK values. Set vario needle type to vario or relative and SC needle type to netto or relative.

See chapter 5.7.8.1.2 for details.

7.7.7 Audio source

When HAWK option is activated, audio source can be chosen between HAWK or TE vario. See chapter 5.7.9.2.5 and 5.7.9.2.6 for more details.

8 Flying with the LXNAV S8x/S10x

To get the best out of the LXNAV S8x/S10x it is important that some preparation is made prior to take-off. Trying to configure the instrument or set a task while flying is very hazardous especially in a competition. Pre-flight preparation will help ensure that the flight will be both safe and enjoyable.

8.1 On the Ground

8.1.1 Power on Procedure

Press any of the rotary or push buttons to start the LXNAV S8x/S10x. The LXNAV S8x/S10x welcome screen will appear. The first screen shows the version of the boot loader, firmware, hardware and serial number. The boot procedure normally takes a few seconds. When completed the Set Elevation dialogue is displayed.

8.1.2 Set Elevation and QNH

This setting is crucial for final glide calculation: therefore please pay careful attention to it.



The instrument will offer elevation over standard pressure level QNE. Use the knob to fine-tune the elevation.

The **QNH** should be changed only when airfield elevation and QNH pressure are given. This might happen in some competitions.

In all other cases the elevation should always match QNH pressure.



The Set Elevation dialogues are not shown if the LXNAV S8x/S10x is switched off and on during flight.



QNH can be also corrected during flight under Setup-QNH and RES menu.

8.1.3 Pre-Flight Check

After elevation setup the LXNAV S8x/S10x will switch to the Info screen for normal operation mode.

Use the middle (Menu) button to scroll to the FLARM, Waypoint or Task Screen to verify that the MacCready, Ballast and Bugs settings are set to the expected values for the current flight.

In any of these screens press the lower rotary button to raise the dialogue box to check or set MacCready, Ballast and Bugs values.



Rotate the lower knob to modify any setting. Next check the safety altitude (height above destination, arrival altitude) setting.

Refer to Chapter 5.7.1.2 to find how to define the safety altitude.

8.2 Airborne

8.2.1 Final Glide Calculation

Final glide is a function calculated from the target distance, target elevation, altitude, wind component, MC setting and Bug setting. The S8x/S10x will have sufficient information to calculate this automatically if a GPS source is attached and the target to navigate to is set in the Waypoint or Task screen. To display the Arrival Altitude (above Safety Altitude) make sure you have configured at least one of the navboxes on the primary or secondary screens to Arrival Altitude.

9 Installation

The LXNAV S8x/10x requires a standard 57 or 80mm cut-out.

Three pressure connectors are fitted to the back of the S8x/S10x. A label shows their functions:

- P_{static} means static pressure connector.
- P_{total} means pitot or total pressure connector.
- TE means total energy TE pressure connector.

If the unit is to be configured for electronic TE compensation the connections are as follows:

- P_{static} Static
- P_{total} Pitot or Total pressure
- TE/ P_{static} Static

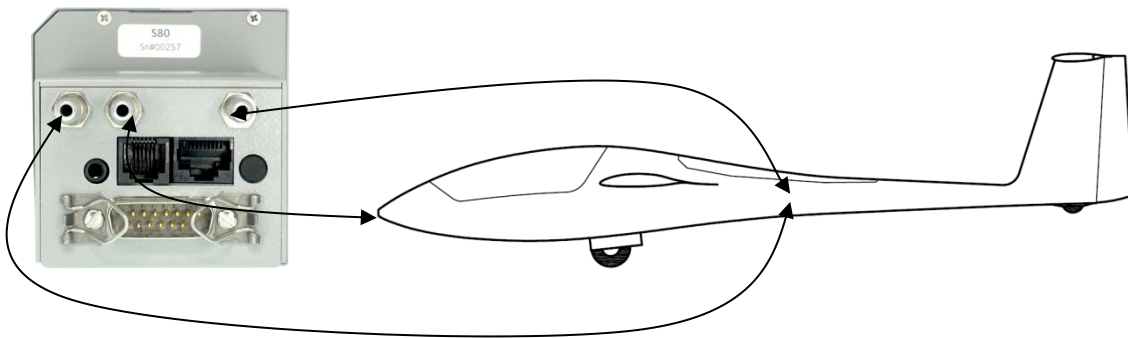

If the unit is to be configured for pneumatic TE compensation using a TE tube, then the connections are:

- TE/ P_{static} TE tube
- P_{static} Static
- P_{total} Pitot or Total pressure

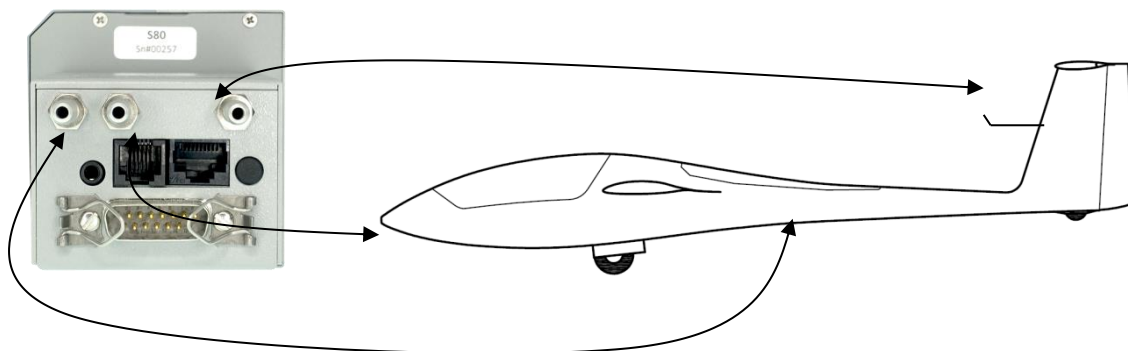

If the P_{total} and Static are connected the wrong way around there will be no integrator (average climb) and speed to fly indication during the flight.

The LXNAV S8x/S10x is connected to 12 Volt power supply via the 15-pin SUB-D connector. Optionally the LXNAV S8xD can be connected via the CAN bus and the connectors are labelled with "**CAN**" at each end.



The instrument has no internal fuse. **A 3A external fuse is required!** Power supply cables should use a minimum of 0.5 mm² wires.

9.1 Installing the LXNAV S8x/S10x

The LXNAV S8x/S10x vario should be mounted in a standard 80 mm hole.

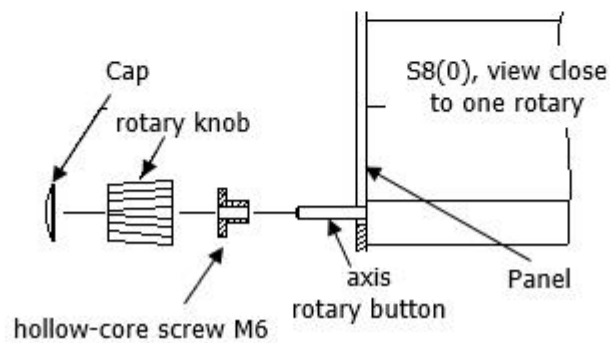

Remove the two rotary knob caps with a knife or flat screw driver, then hold each knob and unscrew it. Remove the remaining two screws and the two M6 threaded nuts. Install the S8x/S10x into the panel and screw back all screws, nuts and knobs. Ensure that between the knobs and the panel there is sufficient space so that the button can be pushed.



Ensure that the LXNAV S8x/S10x is located far enough from the compass.



Ensure that the LXNAV S8x/S10x is located far enough from the vario speaker to avoid ENL sensor problems.

9.2 Connecting the LXNAV S8x/S10x

The LXNAV S8x/S10x is connected to the 12V DC power supply. The red wire goes to + positive and blue wire goes to – ground. If you don't use the S8xD (second seat unit) the Can connector should be left terminated with a CAN terminator. The SC cable is used for the external switch intended for switching between climb and cruise mode.

9.3 Cut-outs

9.3.1 Cut-Out for S8 and S10

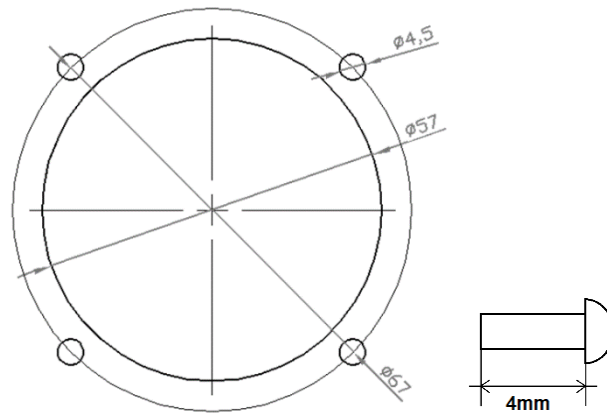

9.3.2 Cut-Out for S80 and S100

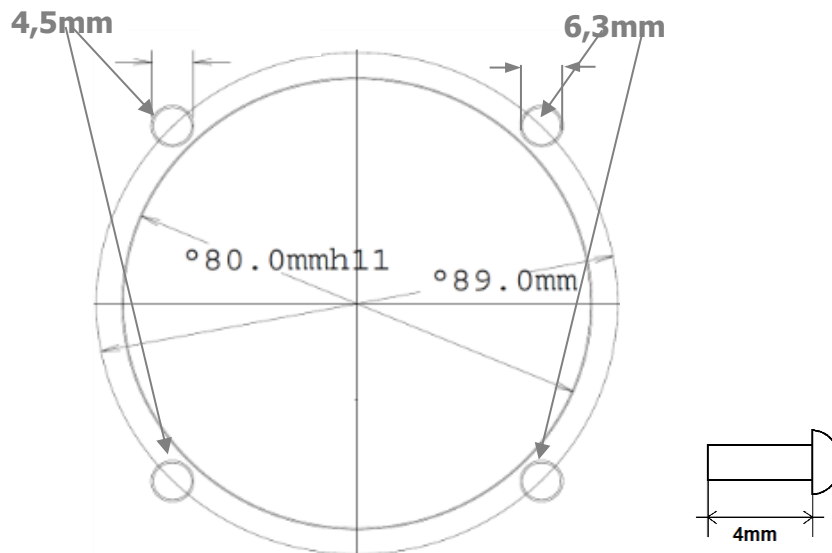

The length of the screw is limited to max 4mm!

9.4 Available Cables for GPS/FLARM and PDA Ports

GPS / FLARM Port (on S10x)

Device	Cable Code
Nano power	CC-NP-LX (<i>RX/TX are crossed</i>)
Generic RS232 with female DB9	V7-GPS-232
Flight recorders, FLARMs with standard 6p IGC connector RJ12 type, Red Box, Colibri, Colibri2, VL	V7-GPS-IGC
PowerFLARM (RJ45), K6 mux	V7-GPS-PF
PowerFLARM Core	V7-GPS-PFCORE

PDA Port (on S10x and S10xD)

Device	Cable Code
OU DIE	CC-NP-OU DIE1
Generic RS232 with female DB9	CC-NP-232
IPAQ 310/314	CC-NP-IPAQ310
IPAQ 38/39xx/47xx	CC-NP-38
MiniMap	CC-NP-LX
Butterfly Connect	CC-NP-BFC



The PDA and GPS ports are not designed in accordance with the IGC standard. They can be used only with a dedicated cable. Do not plug an unknown cable into them as it may damage the LXNAV S8x/S10x unit.

9.5 Installation of Options

The LXNAV S8x can be connected to a 2nd seat repeater unit LXNAV S8xD, remote stick and AHRS options.

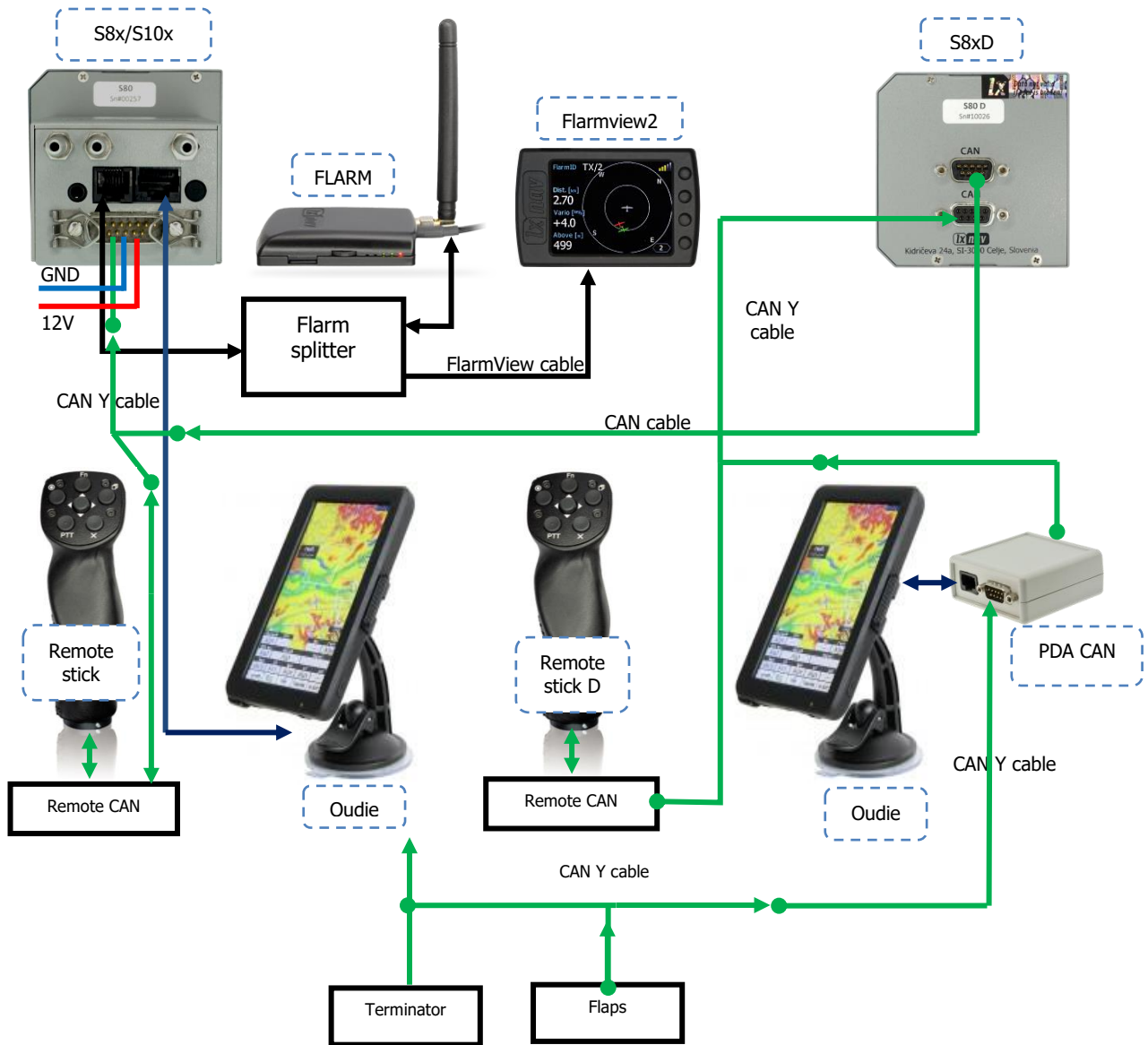

9.5.1 S8xD Option (Repeater)

In two-seat gliders it is possible to install the LXNAV S8xD rear seat device. The S8xD looks almost identical to the S8x; in fact it runs the same software as the first seat device. The basic idea of the two-seat configuration is that both devices work independently from each other with the possibility of automatically exchanging various items of data (volume, Mc, polar...).

9.5.1.1 Data Exchange

All data is exchanged between the front and rear units. The LXNAV S8x/S10x also exchanges data with GPS and PDA. Change of MC, Bal, Bugs, Volume, polar settings... on a PDA will also influence the LXNAV S8x/S10x. The same will happen also in the opposite direction.

9.5.2 Flap Sensor (Flap – CAN)

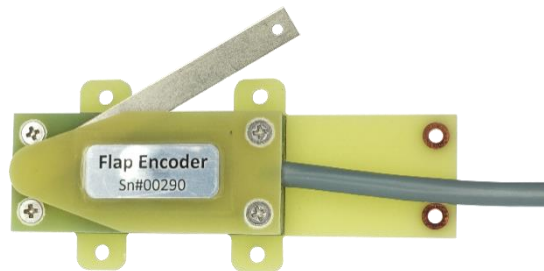

The Flap sensor must be connected to the CAN bus through a CAN bus (Y) splitter. Any remaining ports on the Y CAN splitter must be terminated with a CAN terminator.

9.5.3 Universal Flap Sensor (Flap – CAN, Flap - 485)

Universal flap sensor has two independent interfaces, which can simultaneously communicate via can and RS485 bus. That means, it can be connected to S10x and Lx9xxx at same time. To do that you need to order UNI splitter, which will split the signal on two networks (RS485 and CAN). RS485 part is normally connected to RS 485 network of the Lx9xxx via RS485 splitter and CAN part is connected to CAN BUS network of the S vario via CAN Y splitter.

9.5.4 MOP2-CAN

The MOP2 sensor must be connected to the CAN bus through a CAN bus (Y) splitter. Any remaining ports on the Y CAN splitter must be terminated with a CAN terminator.

9.5.5 MOP2-UNI

Universal MOP2 sensor has two independent interfaces, which can simultaneously communicate via can and RS485 bus. That means, it can be connected to S10x and Lx9xxx at same time. To do that you need to order UNI splitter, which will split the signal on two networks (RS485 and CAN). RS485 part is normally connected to RS485 network of the Lx9xxx via RS485 splitter and CAN part is connected to CAN BUS network of the S vario via CAN Y splitter.

9.5.6 Remote Stick (Remote-CAN)



The remote stick is also connected to the CAN bus. On the S8x/S10x a special menu is provided to register the remote stick. The device must be registered in case of two-seat device; it is possible to have two remote sticks, one registered on the front and another on the rear device. Older types of remote sticks having wired SC button, which can be connected to one of the vario inputs. Newer type has not any more this cable, the function of the front SC button is permanently set to SC toggle.

Registering a remote stick can be done on following way. Press any button on the remote stick – in this way the S8x/S10x will detect the presence of the remote stick on the CAN BUS. After that go under setup-hardware-remote and register the remote stick.



To confirm a remote stick, you must press the OK button on the remote stick.

The same is done with a second remote for S8xD repeater unit. Ensure that when registering the repeater unit that the front unit is not in Register mode, otherwise both units will listen to the same remote stick.



The CAN bus is always under power, consequently the remote stick is also under power. After flight please disconnect the batteries or turn off the master switch to prevent discharging the batteries.

9.5.7 AHRS Option and HAWK option

To activate AHRS or HAWK option an activation code must be purchased. Please contact LXNAV or local dealer to purchase a code.



Once the activation code has been purchased, this option is permanently active on the selected device. Option cannot be deactivated or transferred to another device.

There are two mechanisms to active an option. Using a license file or using a license key.

9.5.7.1 Activation using a license file

This method of activation is very straight forward and preferred way of activation. A license file licence.sxxx is sent to you via email. Copy it to SD card and insert into device. A message with currently active options will be displayed.

9.5.7.1.1 Troubleshooting by installing HAWK

In case that license file is not accepted, please try to format SD card and copy only the license file. Be sure that filename has not changed.

There are many possible reasons for unsuccessful activation. The device will return an error code that points to the issue:

- 0x00 - No error
- 0x01 - No data on CAN bus
- 0x02 - No data on CAN bus
- 0x03 - Failed saving of setting, wait and try again later. There is probably a different data transfer happening already
- 0x04 - Couldn't save the settings
- 0x05 - Couldn't send the settings
- 0x06 - Invalid or corrupted file
- 0x07 - Invalid serial number

9.5.7.2 Activation using a license key

The option can be activated by entering the license key:

- Enter password 30000
- Enter the 13-digit license key you received via email and confirm.

A message with currently active options will be displayed.



Activating AHRS or HAWK option on main unit will also activate it on all the repeaters (second seat devices).



9.6 Ports and Wiring

9.6.1 LXNAV S8x/S10x Ports

9.6.1.1 LXNAV S8x Ports

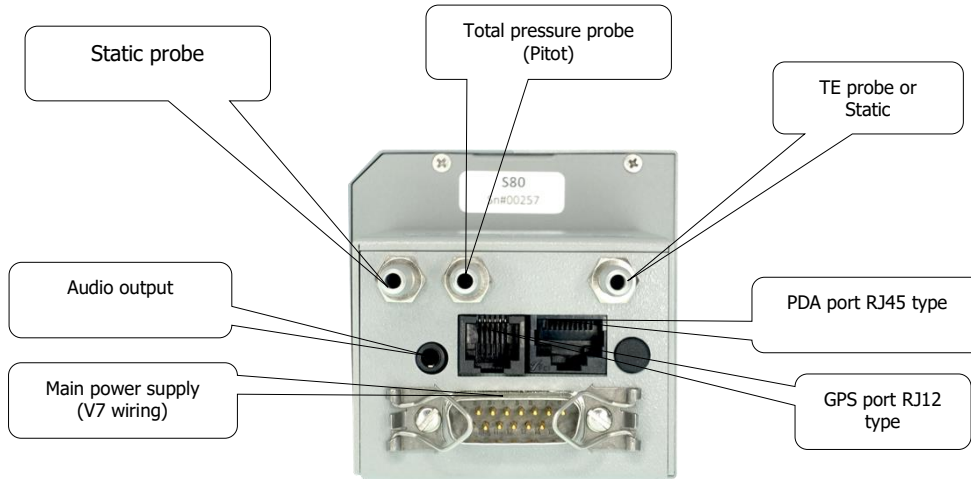

9.6.1.2 LXNAV S10x Ports

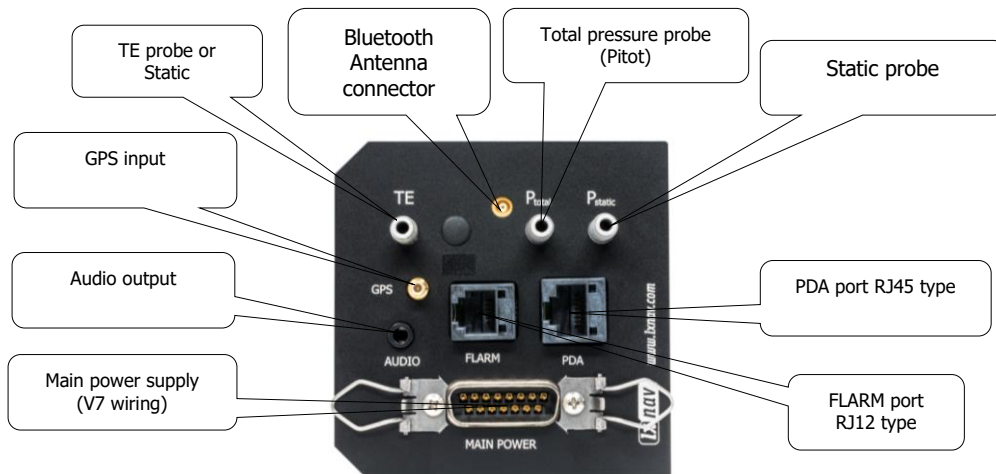

9.6.1.3 PDA Port (RJ45)

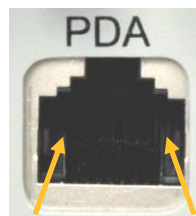

1 2 3 4 5 6 7 8
Pin numbers

Pin Number	Description
1,2	Ground
3	(output) Transmit from LXNAV S8X-RS232 (e.g. Computer, IPAQ38/39xx)
4	(input) Receive to LXNAV S8X-RS232 (e.g. Computer, IPAQ38/39xx)
5	(output) Transmit from LXNAV S8XLV-TTL (3.3V) (e.g. Oudie, HP302, HP31x)
6	(input) Receive to LXNAV S8XLV-TTL (3.3V) (e.g. Oudie, HP302, HP31x)
7,8	5V OUTPUT (maximum 1A)



RS232 pins and TTL pins are using same serial port, therefore they cannot be used for two different devices at the same time..



The RJ45 plug is NOT designed in accordance with the IGC standard. It can be used only with a dedicated cable. Do not plug an unknown cable into it as it may damage the LXNAV S8X unit.

9.6.1.4 GPS Port (RJ12)



1 2 3 4 5 6
Pin numbers

Pin Number	Description
1	(output) 12V DC, to supply GPS (Maximum 2A)
2,3	N.C.
4	(input) Receive to LXNAV S8X-RS232 (e.g. NANO power 232)
5	(output) Transmit from LXNAV S8X-RS232 (e.g. NANO power 232)
6	Ground

9.6.1.5 Main Port

The main port is used to connect the S8X to the main wiring loom.

9.6.1.6 Audio Port

The supplied speaker is connected with a standard 3mm phono jack. The audio amplifier is class D amplifier. It is modern amplifier with low power consumption, high sound quality.



This port is designed to be connected with an 8-ohm speaker supplied with the S8x. Please consult with your dealer if you want to make a different connection.



Class D amplifiers does not allow to connect any pins to the ground.

Wirings

9.6.1.7 LXNAV S8X Wiring

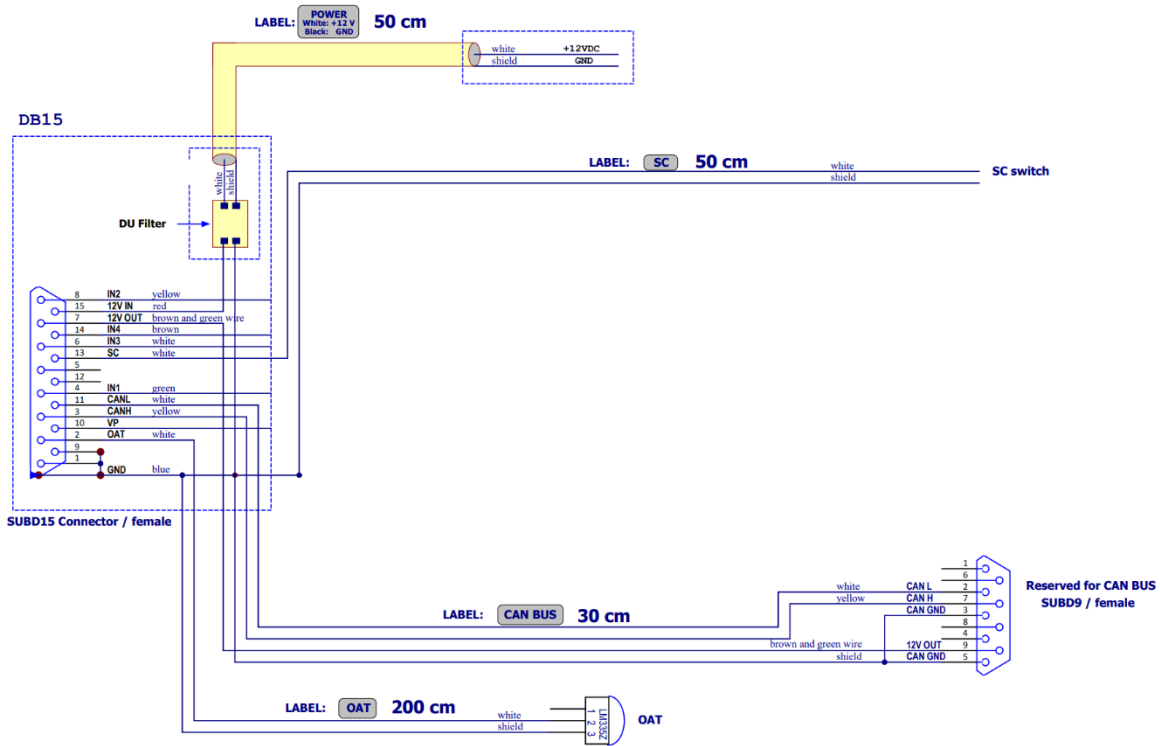

Newer versions of wirings can have the power supply cable shielded with black and white colour. White is +12V DC (positive pole) and black is GND (negative pole)



If a CAN BUS cable is not connected to an LXNAV S8xD, the CAN connector must be terminated with a CAN TERMINATOR!

9.6.1.8 LXNAV S10x Wiring

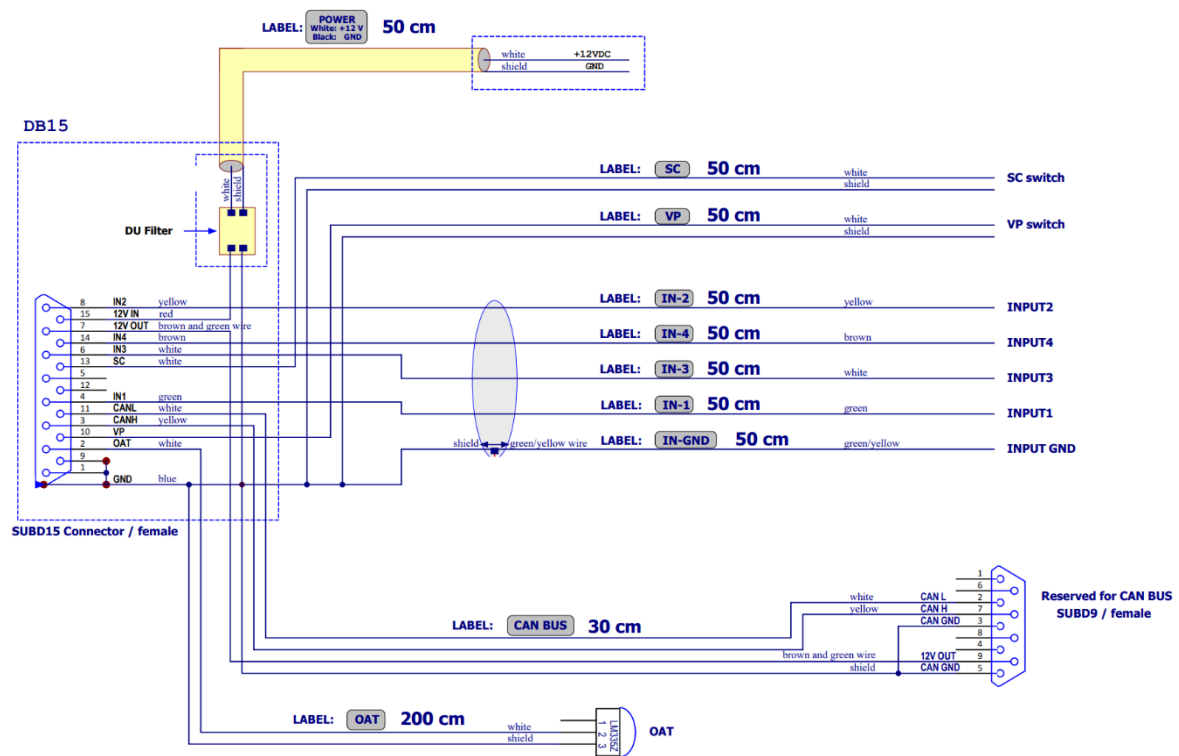

9.6.1.9 LXNAV S8xD/S10xD Wiring

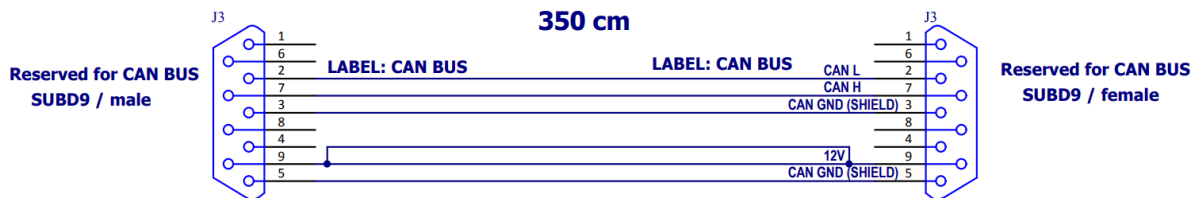

The rear seat device is powered from the first seat device.

9.7 S8x/S10x Configurations

9.7.1 Symbols

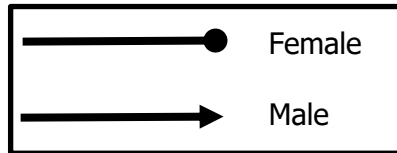

9.7.2 Using external BT module

LXNAV supplies two different external Bluetooth modules:



Bluetooth module for S varios BT3.0 is plugged into PDA port and will be automatically configured by S-varios. Direct link will work with this module. It supports Bluetooth 3.0 protocol. (Old devices like Oudie etc.)



Bluetooth module for LX-PDA 4.0LE is also plugged into PDA port. However it works only at 115200bps, which must be set by user. Direct link is NOT working. It supports Bluetooth 4.0 protocol (New phones: iPhone, Samsung etc.)

9.7.3 Nano/Nano3 – Sxxx - MiniMap

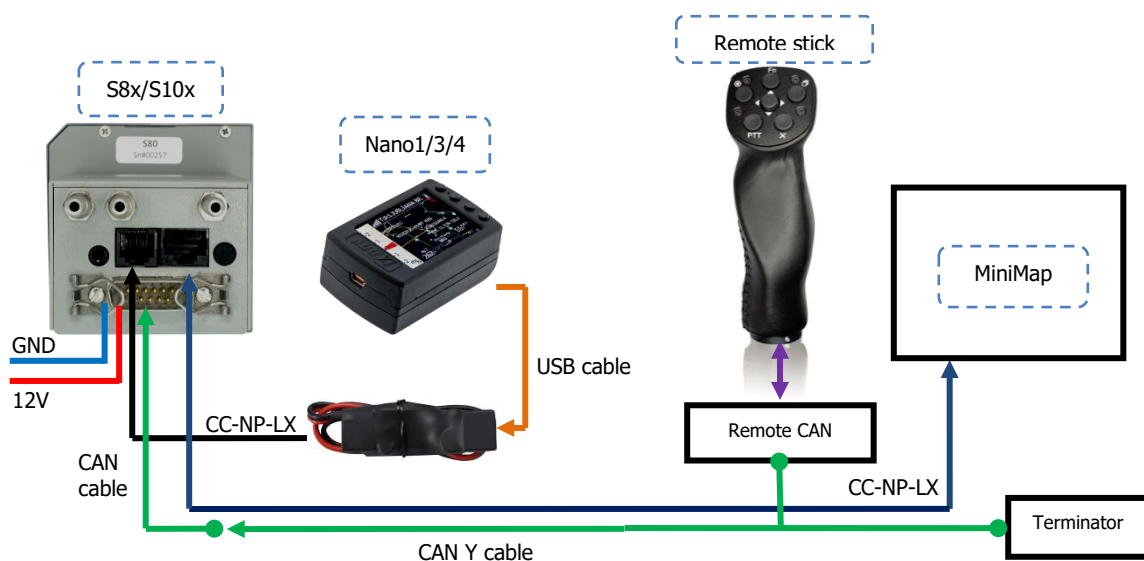

9.7.4 Nano3 - Sxxx - Oudie

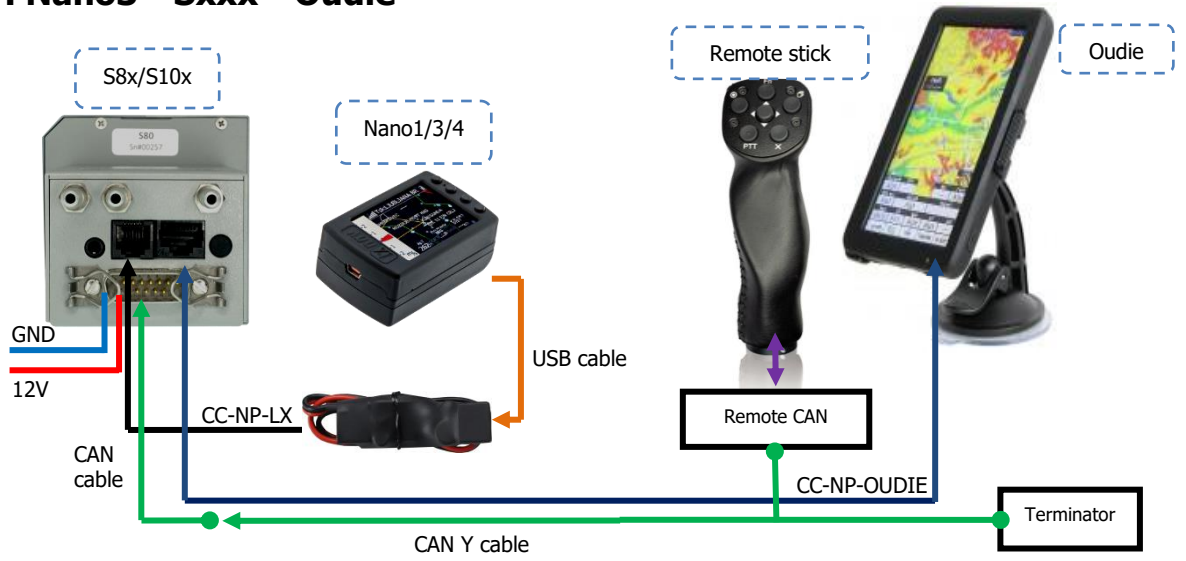

9.7.5 Colibri II – Sxxx - Oudie

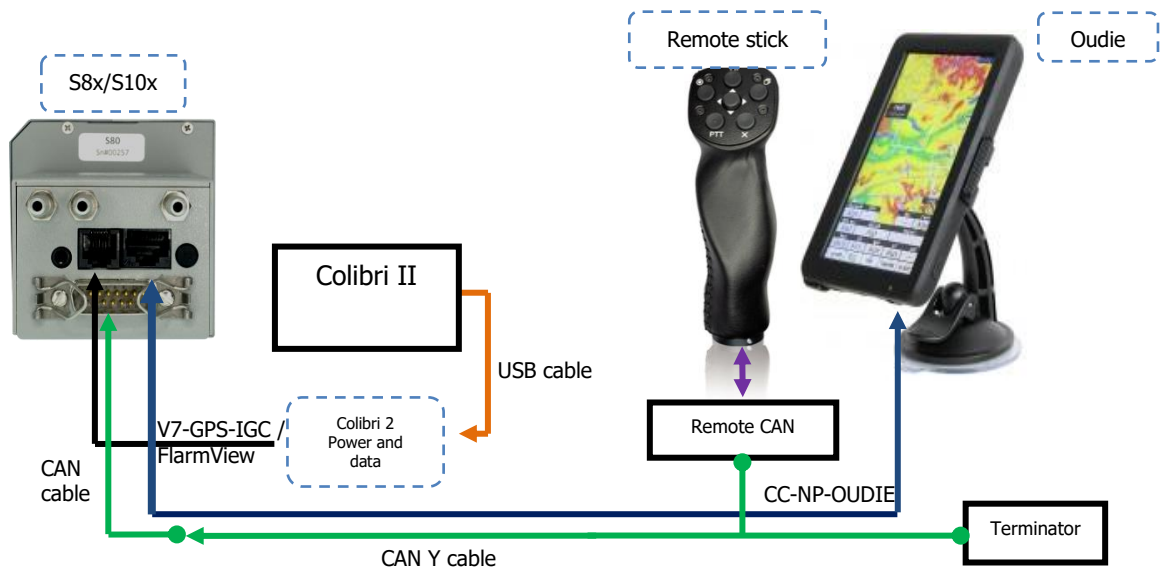

9.7.6 Colibri/Volkslogger - Sxxx - Oudie

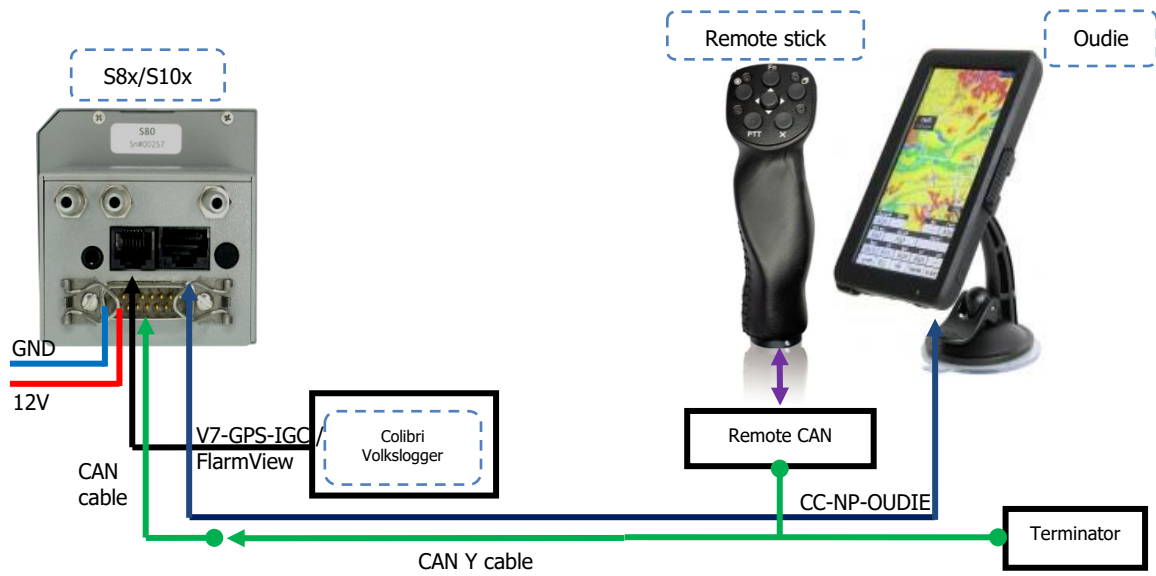

9.7.7 Colibri/Volkslogger - Sxxx - Oudie

9.7.8 FLARM – Sxxx - FlarmViewX - Oudie

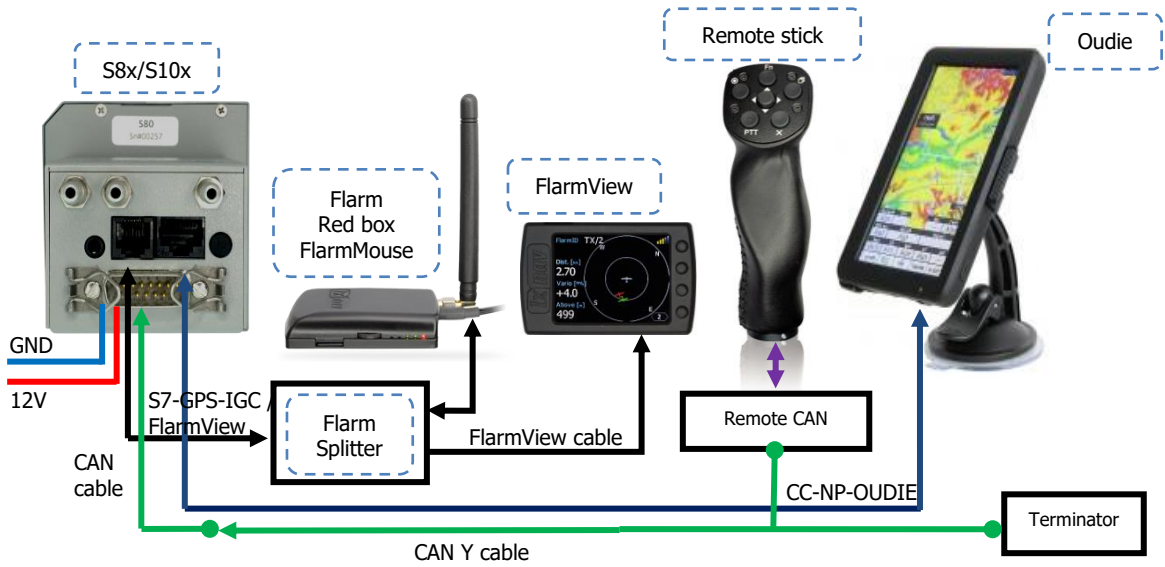

9.7.9 FlarmMouse - ADSB – Sxxx - FlarmView - Oudie

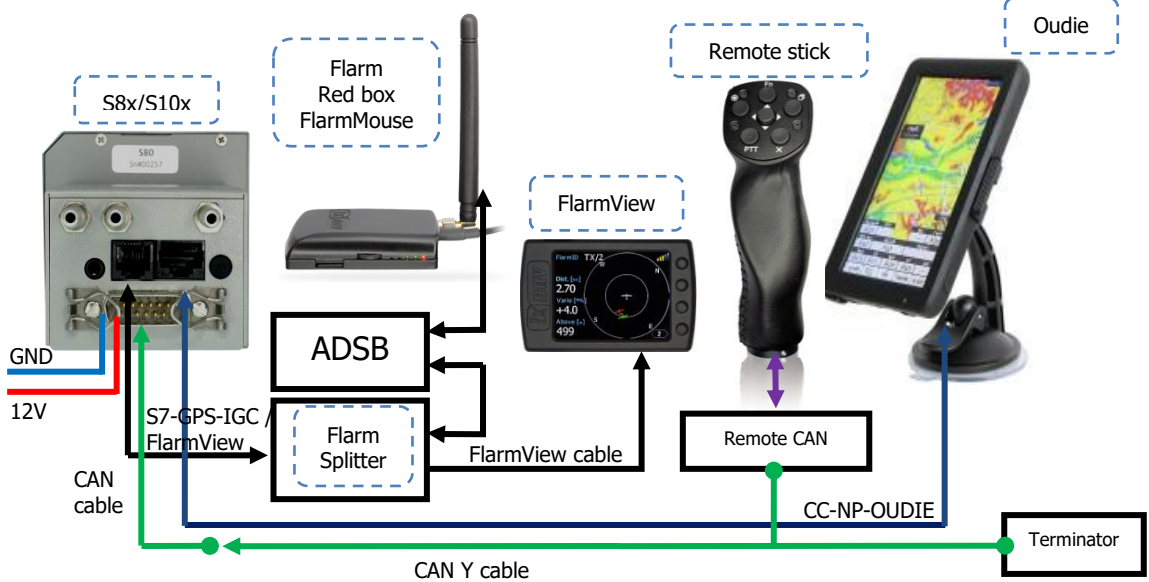

9.7.10 FlarmMouse – Sxxx - Oudie

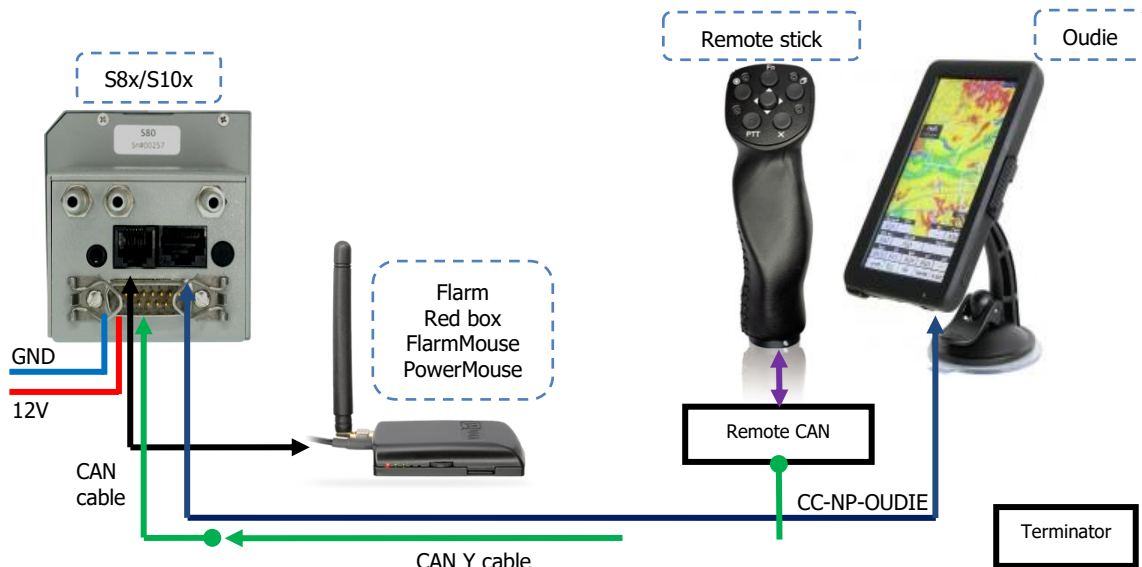

9.7.11 FlarmMouse – Sxxx – Oudie – Flaps Sensor

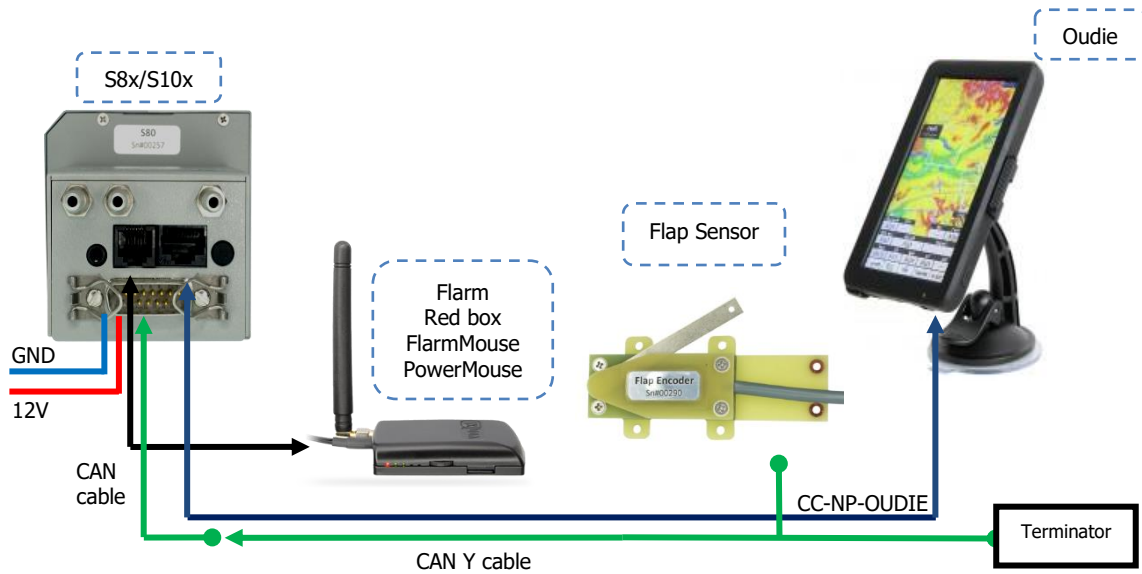

9.7.12 FlarmMouse - Nano3 - Sxxx - Oudie

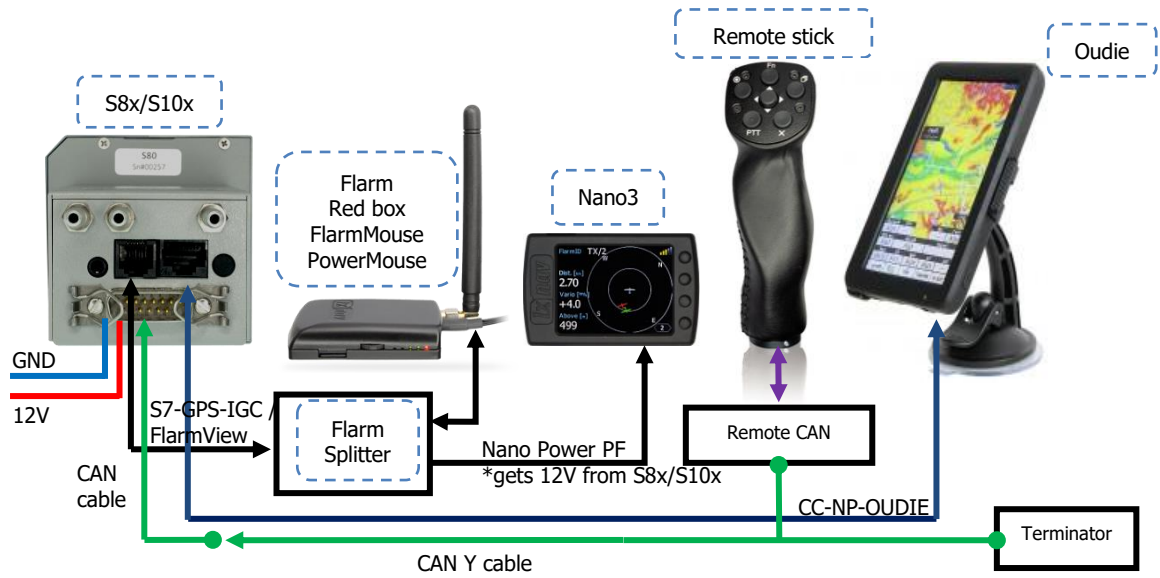

PowerMouse + (Nano3) - Sxxx - Oudie

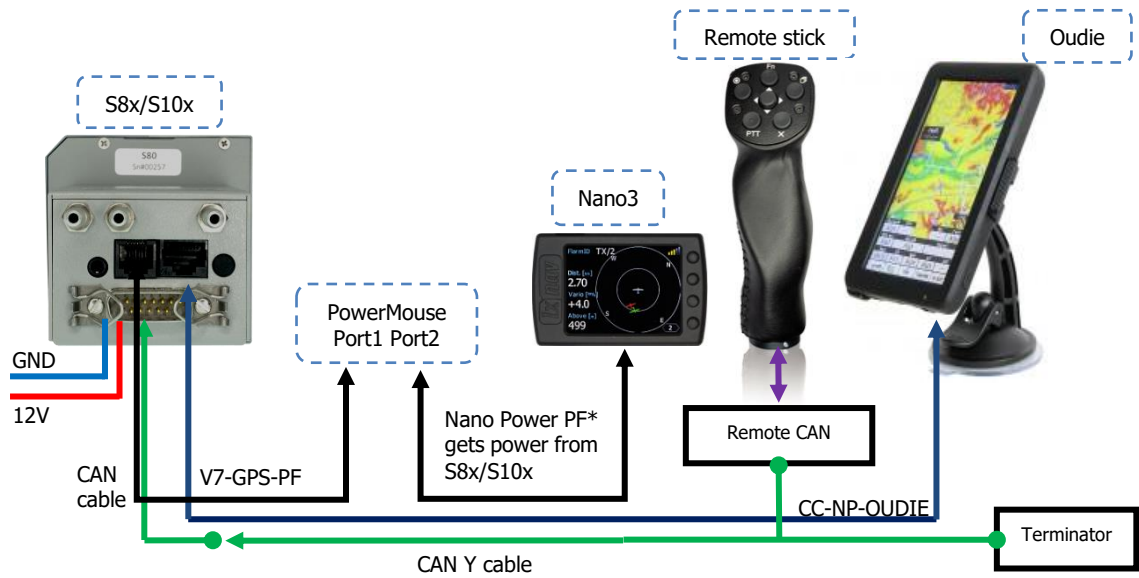

9.7.13 S8x/S10x– S8xD/S10xD

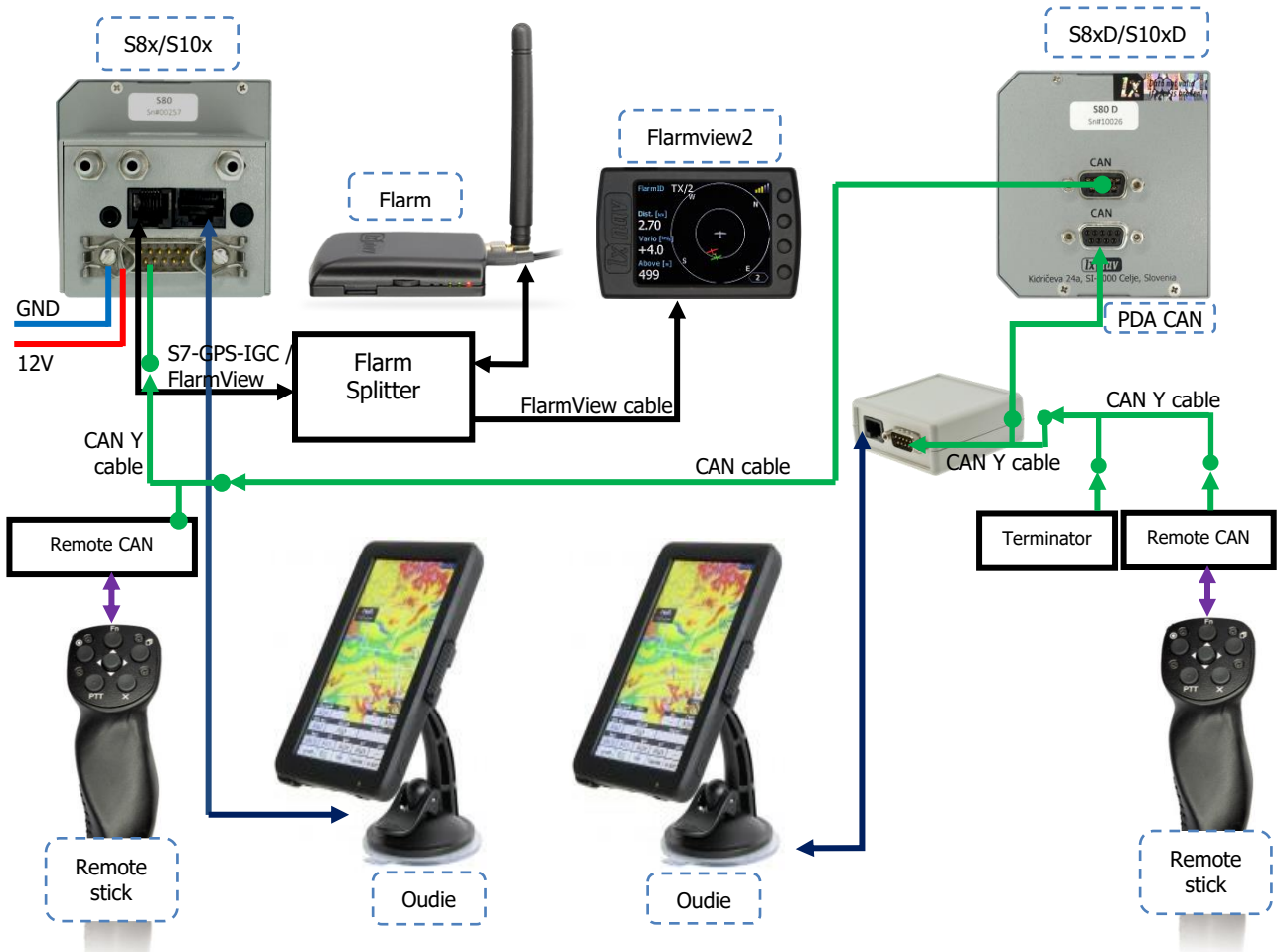

9.7.14 S8x/S10x– Flarm UNI/MOP UNI –(LX80xx/90xx)

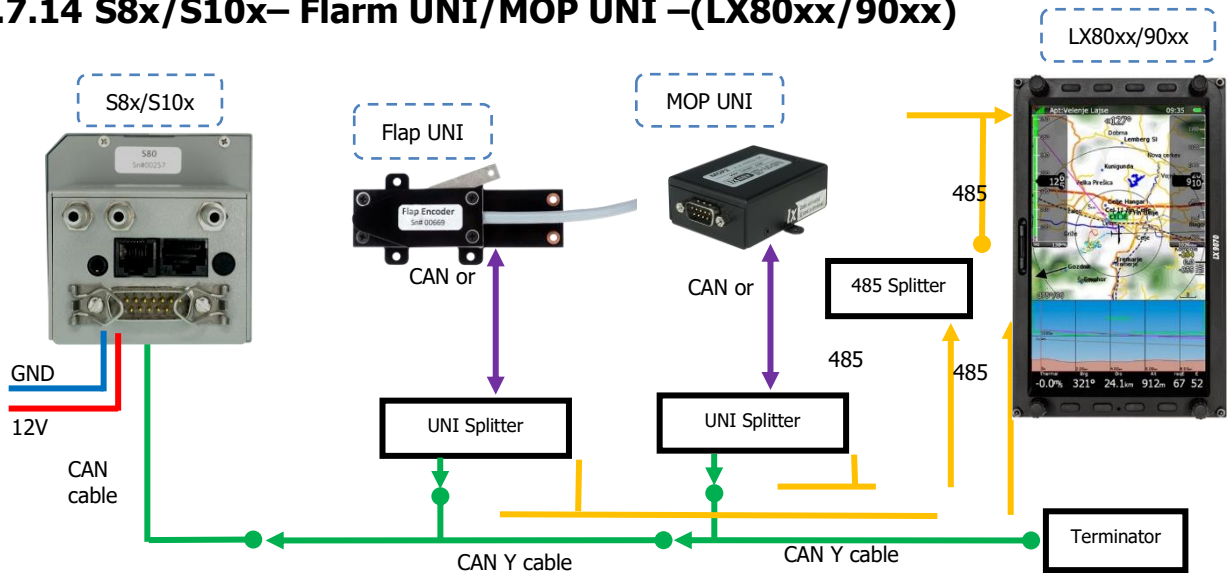

Sxxx Vario Connection to a LXxxxx

All LXNAV standalone varios with a PDA port can be connected to a LXxxxx system. The biggest advantage of connecting them is the ability to declare tasks from the LXxxxx to the stand-alone vario. Cables and adapters needed are: LX5FL, CC-NP-LX and FlarmSplitter. On the FlarmSplitter use only the *RX/TX* ports for bidirectional communication.

Option 1: From Sxxx **PDA** to LXxxxx on a **5pin** Connector (to the **GPS** port can be connected external flarm)

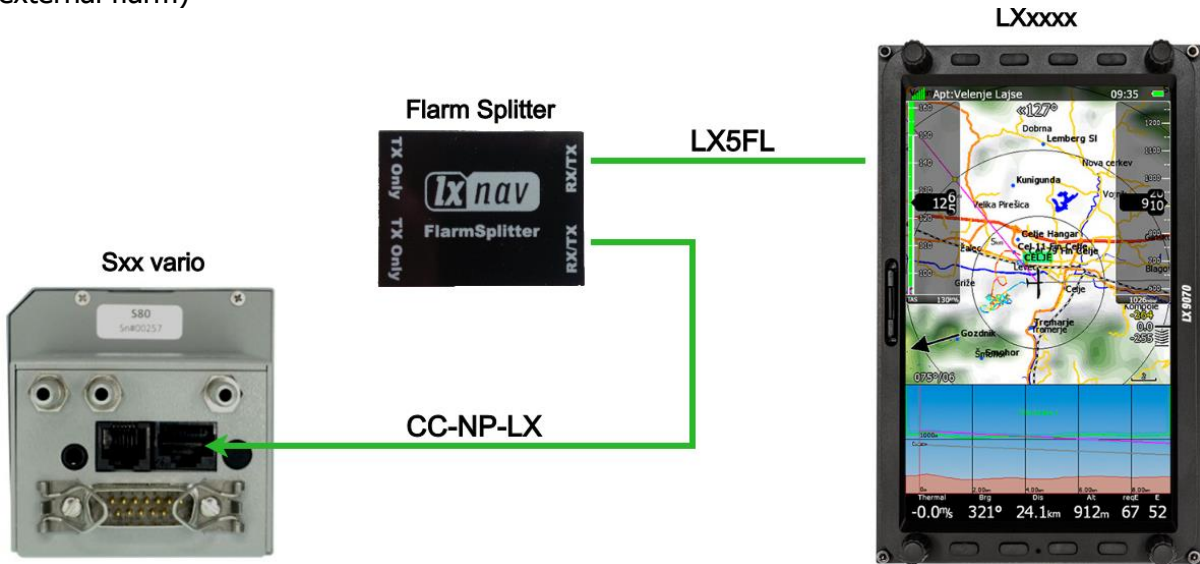

Option 2: From Sxxx **GPS port** to LXxxxx on a **5pin** Connector using **LX5-SVAR**. (PDA port is free to connect Oudie or other PDA device)

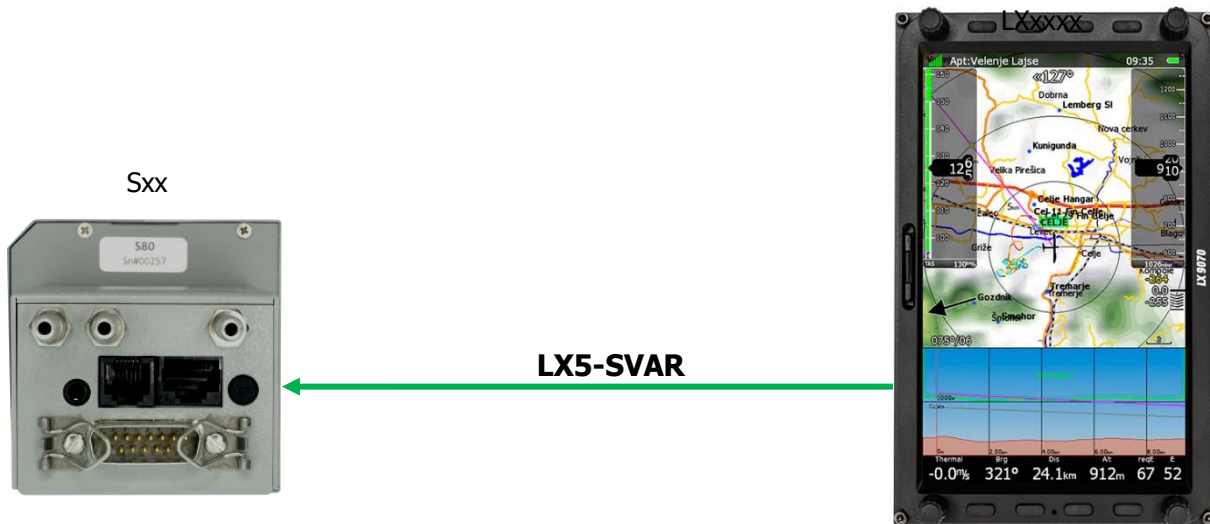

This configuration is used for example when using your Sxx vario together with Oudie and LXxxxx. **LX5-SVAR** is connected to **GPS port** and **CC-NP-OUDIE** cable to **PDA port**.

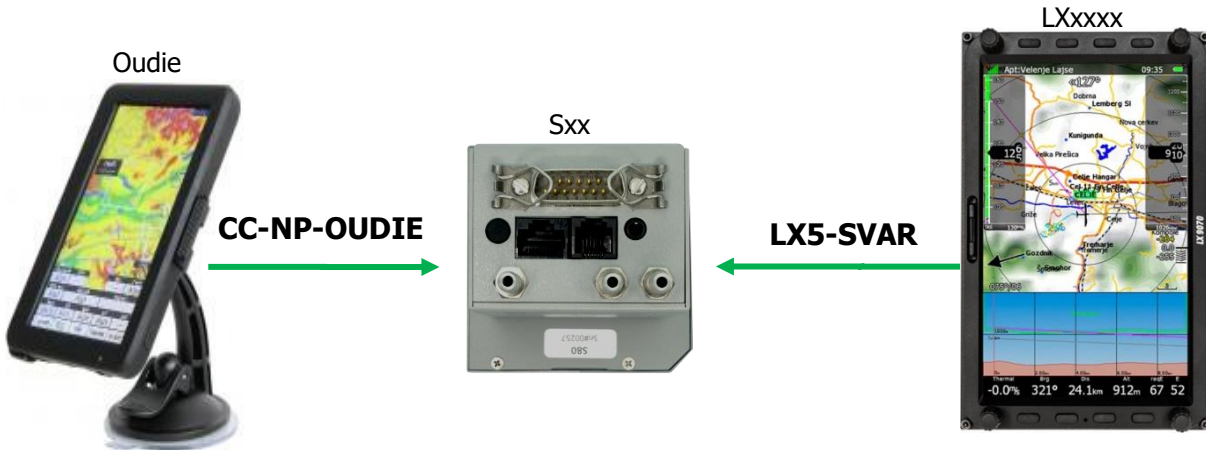

Option 3: From Sxxx **PDA** to LXxxxx on **5pin** connector (to the **GPS** port can be connected external flarm)

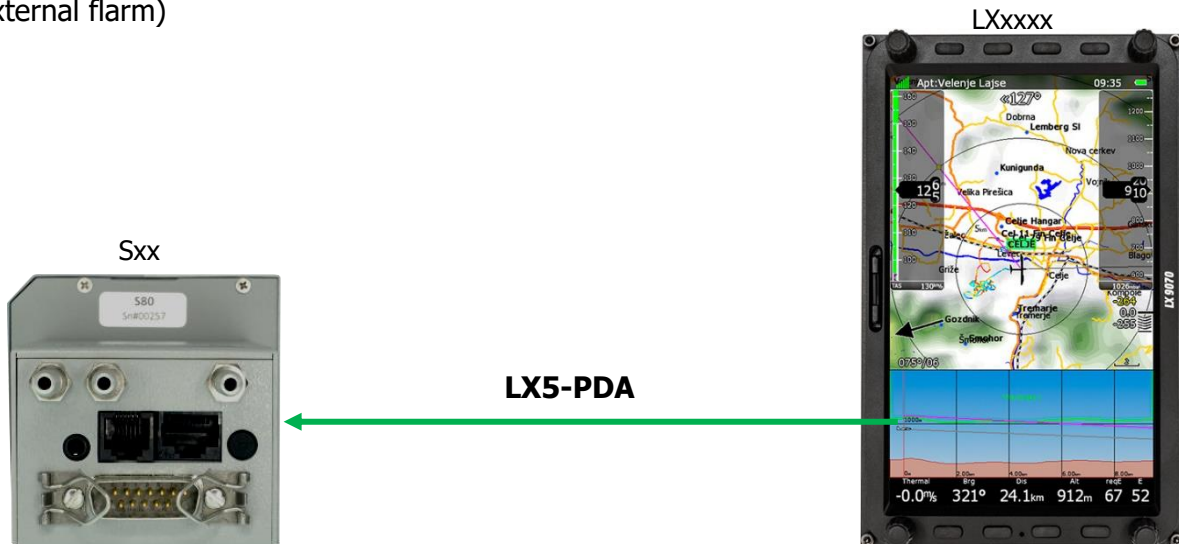

This configuration is used for example when using your Sxx vario together with LXxxxx and Flarm device (e.g. FlarmMouse). LX5-PDA is connected to **PDA port** and **external flarm** to the **GPS port**.

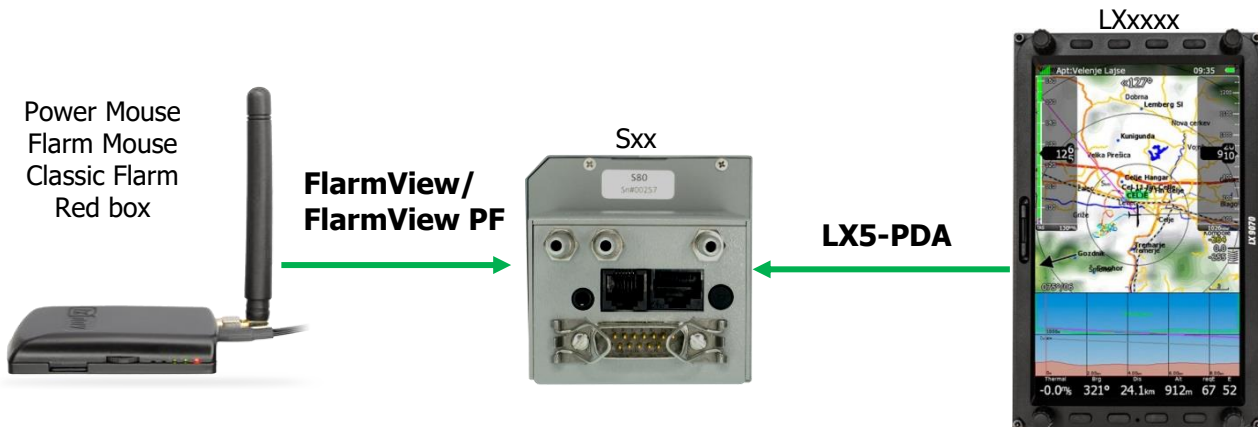



Task declaration is performed automatically after editing the task and after pressing the button OK when in Task Edit mode. Please enable LXWP1, LXWP2 NMEA sentences



McCready, Ballast and Bugs settings are also exchanged, but only in the direction LXxxxx -> Sxx. If you edit this setting on your Sxx device, they will not be transfer to the LXxxxx unit.

9.8 Data Transfer

9.8.1 S8x/S10x

			Data Transfer/Action	Remark
S8x/S10x	↔	Oudie / Oudie BT	MC/Ballast/Bugs; ALT; TSK declaration; Pilot declaration	
S8x/S10x	→	FLARM	Task declaration	
S8x/S10x	→	Nano / Nano3	TSK declaration	
S8x/S10x, also BT	↔	XC soar	MC/Ballast/Bugs; ALT; TSK declaration; Pilot declaration	

9.8.2 Other Data Transfers

			Data Transfer/Action	Remark
FLARM	→	XC soar / Oudie	Flight transfer	Via direct link
XC Soar/Oudie	→	FLARM	Task declaration	Via direct link
Nano/Nano3	→	XC soar / Oudie	Task declaration, flight download?	Via direct link

10 Firmware Update

Firmware updates for the main display indicator and vario unit can be easily carried out using the micro-SD Card. Please visit our webpage www.lxnav.com and download the firmware update.

You can also subscribe to a newsletter to automatically receive news about the system.

10.1 Updating LXNAV S10x and S8x Firmware Using a Micro SD Card

Copy the firmware **ZFW** file type to the SD card and insert into the device. The S10x will ask you to update. After confirmation the firmware update will be performed automatically.



The rear seat device is not automatically updated while updating the first seat, thus it needs to be updated separately.

10.2 Updating LXNAV S8x Firmware Using a Micro SD Card (up to fw. 5.43)

Unzip the file from the website and put all three files to the SD card:

- App_NINC_X.YY.lxfw
- V80C.fw
- V80c_init.bin

If any of these files are missing or are corrupt, the firmware update will not be successful. Transfer the firmware update files to the micro-SD card and insert it into the S8x. The unit will ask you UPDATE? Confirm and reboot the S8x unit. The update will be performed automatically.

10.3 Updating LXNAV S8x Firmware Using a Micro SD Card (OLD Method)

The firmware consists of two parts, vario and display.

The firmware can be downloaded from the download-firmware section on www.lxnav.com. It is a compressed ZIP file which must be firstly uncompressed. Inside are three files:

- App_NINB_X.YY.lxfw (this is firmware for vario part),
- V80C.fw (first part of firmware for display part),
- V80c_init.bin (second part of firmware for display part).

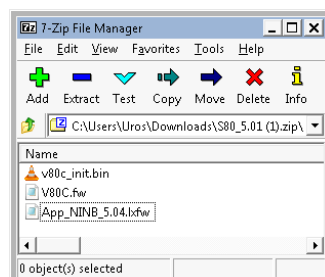

If some of these files are missing or are corrupt, the firmware update will not be successful. Transfer the firmware update files to the micro-SD card and insert it into the S8x. Reboot the S8x and the update of the display part will be performed automatically.

If automatic detection will not start, please follow the procedure below:

- Go to the Setup screen and select the password option.
- Enter the password 89891 - this will bring you to the firmware update menu.
- Choose the correct firmware for the vario part and press update.



10.4 Incomplete Update Message

If you get an incomplete update message, you need to unzip the ZFW firmware file and copy the content to the SD card. Insert it into the unit and power on.



If you can't unzip the ZFW file, please rename it to ZIP first.

The ZFW file contains 3 files:

- V8xc.fw
- V8xc_init.bin
- App_NINC_XX.lx_fw

If V8xc_init.bin is missing, the following message will appear "Incomplete update ..."



All updates after version 5.45 contains all 3 files in one zip file

11 FAQ

1. How can I save the IGC file?
Go to the logbook page, select the flight of interest, short press on the lower rotary button and download the flight to the micro-SD card.
2. Is it possible to interface with an iPad/iPhone/other iOS device?
That is not possible.
3. I don't see how you charge the actual unit whilst it is installed into the plane?
Via the main power cable which is supplied with the device.
4. Do I have to put the fuse between the master switch and battery?
Yes, use a 3A fuse.
5. Can pin 3 of the (now free) PDA port be configured to provide ADSB data at 4800 baud and a NMEA filter (GPRMC only) to a transponder?
No, the PDA port is our standard and will never be changed. For a transponder we can provide a NMEA bridge.
6. Does the Bluetooth connection with the Oudie have all functions of the PDA port?
Yes.
7. Can the original old flat FLARM box be connected to the FLARM port?
Yes
8. Does the delivery include an external GPS aerial on the S10x?
Yes, but only on the S10x.

12 Revision History

Rev	Date	Comments
1	October 2014	Initial release version 4.9
2	November 2014	Updated Sections 9.5.2, 9.5.2
3	December 2014	Updated Sections 5.3.2, 5.5.1.2, 7.2.1
4	January 2015	Updated Section 5.7.13.2
5	January 2015	Typos, release 4.97a
6	January 2015	New cables for PDA and GPS port ch.9.4
7	March 2015	New sections for thermal assistant and logbook
8	May 2015	Typos, release 501e
9	June 2015	Release 501f, updated ch.9.5.2, updated ch.5.7.5.1
10	June 2015	New Section Quick access menus 0
11	March 2016	Complete review of the manual added S10x
12	June 2016	Units Section, Warnings, Added OAT to Info page, update procedure for S8x, Voice warnings completely described
13	August 2016	Review of English language content (Thanks to Howard Mills)
14	August 2016	Added Flap navboxes
15	August 2017	Updated Section 0, Updated connection schemes 9.7
16	September 2017	New Sections 5.7.13.8, 5.1.3.1.1
17	October 2017	New Section 5.7.16
18	December 2017	Updated Section 9.5
19	January 2018	Minor change in Sections 0, 0
20	March 2018	New Section S8/S80 Club 3.2.3, CAN Bridge 5.7.11.7, AHRS 5.7.11.9 and Flaps 5.7.11.8 Updated Sections: 5.7.2, 5.7.3, 5.7.12, 8.5.5
21	June 2018	New Sections: 5.1.15, 5.1.16, 5.1.17 Updated Sections: 5.2, 5.7.8, 5.7.12, 5.7.16
22	July 2018	Added Section: 8.7.9 Updated Section: 5.7.11.8
23	November 2018	Corrected ch.5.7.9.2.4, Updated:2.5,2.6
24	February 2019	Updated/Corrected/Added: 5, 0, 5.1.3, 5.1.3.2.1, 5.1.5, 5.1.6, 5.7, 5.7.5.2, 5.7.5.1, 5.7.5.3, 5.7.5.4, 5.7.8.1, 5.7.8.1.8, 5.7.8.1.9, 5.7.8.2, 5.7.8.4.2, 5.7.8.6.2, 5.7.8.7.1, 5.7.11.1, 5.7.11.1.2, 5.7.11.1.7
25	March 2019	Updated 5.7.13.8.2
26	June 2019	Added: 0, 0, Updated: 5.7.16.1
27	July 2019	Review of English language content Added: 5.7.11.4.1
29	September 2019	Updated: 0
30	December 2019	Updated chapter:5.7.13.6
31	February 2020	Updated chapters: 5.7.13.3.4, 3.2.4.1
32	April 2020	Updated chapters: 5.1.3.2.1 Added: 5.7.3.8.1
33	September 2020	Minor fixes, removed ch. 5.7.8.1.9
34	September 2020	Style update
35	April 2021	Updated chapter 9.5.6
36-38	April 2021	Added HAWK chapters
39	May 2021	Clarified terms relative, vario and netto in HAWK chapters
40	May 2021	Added chapter 5.7.13.3.5, Updated chapter 9.6.1

41	May 2021	Updated wiring schemes
42	July 2021	Minor fixes
43	July 2021	Updated Ch. 5.1.10
44	August 2021	Updated Ch. 5.7.2.4, Added ch.3.2.4.3
45	September 2012	Updated: 0
46	September 2021	Minor fixes
47	November 2021	Updated Ch. 3.2.4, 9.6.1.2., version and minor fixes
48	November 2021	Replaced SIGWIND with Wind variance
49	December 2021	Updated Ch.9.6.1.6
50	April 2022	Updated Chapter 7 HAWK
51	April 2022	Added Chapter 5.7.13.8.5, 9.5.7.1.1
52	July 2022	Added chapter 9.5.3,9.5.4,9.5.5
54	August 2022	Updated Ch. 3.2.4.1
55	November 2022	Updated Ch. 7.7.4
56	November 2022	Updated Ch. 5.7.13.1.3
57	December 2022	Removed Compass references, Added Ch. 3.2.4.4, 9.7.14 Updated Ch. 9.7.12, 9.5.7.1.1
58	January 2023	Updated Ch. 5.1.10.1.1
59	April 2023	Updated Ch. 5.1.10.1.1
60	May 2023	Updated Ch. 5.7.13.2.5
61	June 2023	Updated Ch. 5.7.8.6.55.7.13.2.5
62	October 2023	Updated ch. 10.4

The pilot's choice



LXNAV d.o.o.

Kidričeva 24, SI-3000 Celje, Slovenia

T: +386 592 334 00 | F: +386 599 335 22 | info@lxnav.com

www.lxnav.com