

ASK 21

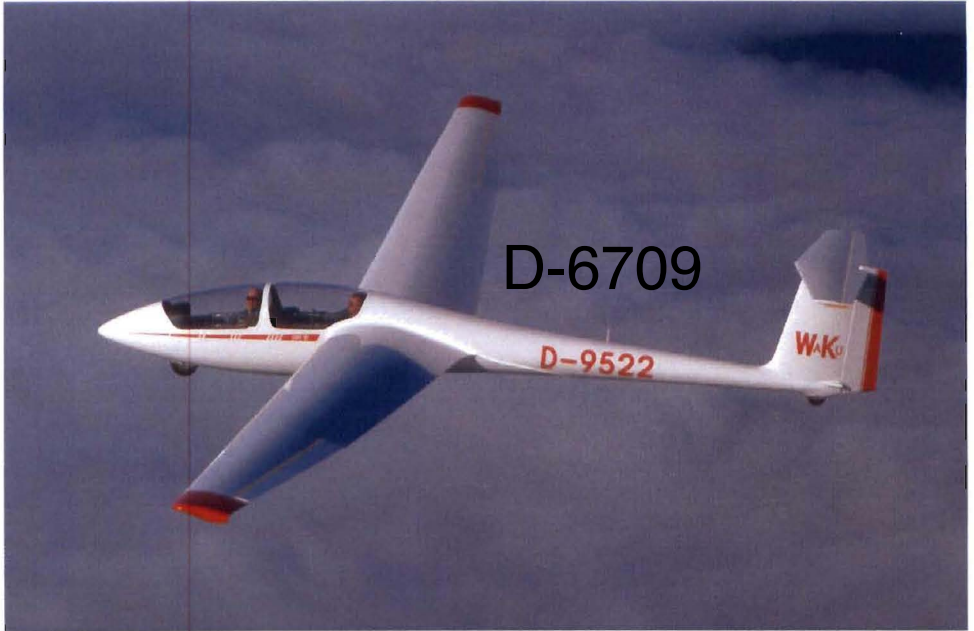

Flight Manual

D-6709

ALEXANDER SCHLEICHER SEGELFLUGZEUGBAU
6416 Poppenhausen/ Wasserkuppe, West Germany

FLIGHT MANUAL
for the sailplane model

ASK 21
=====

This manual must always be carried on board !

It belongs to the sailplane ASK 21

Variant Data Sheet no.339

Serial no.: 21688...

Registration no.: D-6709

Owner : AAVA.....
.....
.....

Manufacturer : Alexander Schleicher
Segelflugzeugbau
6416 Poppenhausen/ Wasserkuppe
West Germany

This manual is the translation of the German original which is approved by the LBA (Federal Office of Civil Aeronautics of the Fed.Rep. of Germany) as operating instructions according to para 12 (1) 2 of the German 'LuftGerPO' (Aviation Equipment Test Regulations).

The translation has been done by best knowledge and judgement. In any case the original text in German language is authoritative.

APRIL 1980 Edition

Annexe 1



Cet intercalaire doit obligatoirement être inséré
devant la page de garde d'un manuel de vol en
langue anglaise

AVERTISSEMENT

Le présent document en langue anglaise est le manuel de vol approuvé par l'Agence européenne de la sécurité aérienne.

En application des dispositions de l'arrêté du 24 juillet 1991 relatif aux conditions d'utilisation des aéronefs civils en aviation générale (« Un vol ne peut être entrepris que si, d'une part les membres d'équipage sont familiarisés avec l'aéronef et son équipement de bord, notamment le matériel de sécurité-sauvetage et les systèmes spéciaux, et d'autre part ont une connaissance pratique de son manuel de vol ou des documents acceptés comme équivalents. »),

Nul ne peut utiliser l'aéronef avec ce seul document s'il n'a pas une connaissance suffisante de la langue anglaise.

A défaut, il appartient au propriétaire ou à l'exploitant de l'aéronef de se procurer une traduction de ce document sous sa responsabilité.

Référence : Instruction du 13/11/2009 relative à la langue des manuels de vol

Check List / 1
=====

Pre Flight Check

1. Main pins safetied ?
2. Rear wing attachment pins: is the safety lock visible above the pin ?
3. Horizontal tail unit pins safetied ? Is the spring retainer engaged ?
4. Elevator pushrod connected ?
Safetied with a spring clip ?
This is not applicable for gliders which use the automatic elevator connection !
5. Aileron pushrods connected ?
Safetied with a spring clip ?
Do not forget the sight control through the access hole cover !
6. Airbrake pushrods connected ?
Safetied with a spring clip ?
Do not forget the sight control through the access hole cover !
7. Check for foreign bodies !

Attention !

With all HOTELLIER quick-release joints one must be able to touch the ball pivot by feeling through the slot in the ball socket. Check the proper engagement of the safety lock by pushing it on to close !

C H E C K L I S T / 2
=====

Pre take off check

1. Parachute connected to harness ?
2. Safety harness fastened ?
3. Airbrakes locked ?
4. Trim lever adjusted to a middle position ?
5. Altimeter adjusted ?
6. Canopies closed and locked ?
Rear canopy !!
7. For flight with only one occupant remove
rear back rest !!
8. Put your toes under the toe-straps !!
Do not flatten the straps !!
Danger of jamming the pedals !!

ASK 21 Flight Manual

I.1 Amendments record

Rev. No.	Title	Page	Date Signature
1	weak link in towrope, TN-No. 6	12	15.04.82 F
2	weak link in towrope, TN-No. 8	12	16.05.82 F
3	Automatic elevator Connection, TN-No. 11	36 a, 36 b, Checklist /1	20.11.83 F
4	Modification of the Flight Manual, TN-No. 13	10 b	23.02.84 F
5	Amendment of the Flight Manual, TN-No. 13 a	10 c 10 b deleted	04.06.84 F
6	New canopy locking system, TN-No. 15	16 a, 17 a, 18 a & 19 a	08.06.84 F
7	Change / supplement to the Flight Manual, TN-No. 20	Checklist /1, 21, 36 a, 36 b & 37	03.11.87 F
8	New production series tow release couplings for aerotow and winch launch, TN-No. 21	Annex	17.08.90 F
9	Checking and exchange of the parallel rocker at the elevator actuator rod, TN-No. 22	36 b, 37 a, 37 b	26.11.90 F
10	Revision of the Flight Manual, TN-No. 23	13, 15, 25, 26	15.04.91 F
11	Rudder actuated by means of hand lever, TN-No. 25 (optional)	16a & 21	17.06.93 F
12	AD 93-001/2/3, L'Hotellier instructions for the maintenance, Rev. E 03/94	Annex	27.04.98 F
13	Extension of service life beyond 12000 operation hours, TN No. 29	43f	04.05.06 mm

Rev.no. / Date

Sig.

Author
Kaiser

Date
April 80

Page no.

2

LBA-amerk.

ASK 21 Flight Manual

Amendments record

Rev. No.	Title	Page	Date Signature

Rev.no. / Date	Sig.	Author Kaiser	Date April 80	Page no. 2 a
----------------	------	------------------	------------------	------------------------

I.2 CONTENTS		<u>Page</u>
I.	General	1
I.1	Amendments record	2
I.2	Contents	3 + 4
I.3	Description	5
II.	Operating limitations	6
II.1	Airworthiness category	6
II.2	Operation range classes	6
II.3	Equipment	7
II.4	Speeds	8
II.5	Load factors	9
II.6	Weights	9
II.7	In flight c.g.	10
II.8	Weight and balance information	10
II.9	Tow releases	12
II.10	Weak link in tow rope	12
II.11	Tire pressure	12
II.12	Cross wind	12
III.	Emergency procedures	13
III.1	Recovery from spins	13
III.2	Canopy emergency jettisoning and emergency bail out	13
III.3	Flights in the rain	14
III.4	Wing dropping	15
III.5	Ground looping	15
IV.	Normal operation procedures	16
IV.1	Cockpit and operating levers	16 - 20
IV.2	Daily checks	21
IV.3	Pre take off check	23
IV.4	Take off	24
IV.5	Free flight	25
IV.6	Low speed flight and wing dropping	25
IV.7	High speed flight	26
IV.8	Cloud flying	26
IV.9	Aerobatics	27 - 34
IV.10	Approach and landing	35
V.	Rigging and derigging	36
V.1	Rigging	36

ASK 21 - Flight Manual

V.2	Derigging	37
V.3	Parking	37
V.4	Road Transport	37
V.5	Preventive maintenance	38
	Airspeed position error	39
	Speed polar	40
	Lubrication scheme	41

I.3 DESCRIPTION

The ASK 21 is a two-seater sailplane with T-tail, fixed nose wheel and dive brakes on upper wing. The main landing gear is sprung.

The sailplane is built in FRP-sandwich-monocoque construction. It may be used for school and high performance flights as well as for aerobatics of the Airworthiness Category 'A'.

Technical Data

Span	17.00 m	(55,74 ft)
Length	8,35 m	(27,38 ft)
Height	1,55 m	(5,08 ft)
Wing area	17,95 m ²	(192,95 sq.ft)
Aspect ratio	16,1	
Max all-up weight	600 kg	(1320 lbs)
Max wing loading	33,4kg/M ²	(6,84 lbs/sq.ft)

II. OPERATING LIMITATIONS

II.1 AIRWORTHINESS CATEGORY

Basis of the type-approval are the Airworthiness Requirements for Sailplanes and Powered Sailplanes (LFSM), issue Oct. 23, 1975, with the Airworthiness Category 'A' (Acrobatic).

II.2 OPERATION RANGE CLASSES

The operation range classes approved for the particular sailplane are indicated by a data placard on the instrument panel (see Maintenance Manual page). Depending on the respective equipment the sailplane may be licensed for traffic for the following operation range classes :

1. Airworthiness Category 'U' (UTILITY)
 - a. According to VFR (during daylight) - with equipment as per II.3 a.
 - b. Cloud flights - with equipment as per II.3 a and II.3 c.

2. Airworthiness Category 'A' (Acrobatic)
 - with equipment as per II.3 a and II.3 b or II.3 a, II.3 b and II.3 c -
 - for the following aerobatics :

Loop, Stall Turn, Split 'S', Immelmann, Slow Roll, Inverted Flights, Spin, Steep Climbing Turn, Lazy Eight, Chandelle.

II.2 cont. Operation Range Classes – Crew

Solo flights may only be conducted from the front seat

With a crew of two, the pilot in command sits in the front seat – unless the occupants agree prior to the flight that the pilot in command sits in the rear seat. For the latter it is necessary, that all controls and instruments are available in the rear seat, and that the pilot is familiar with the operation of the aircraft from this position.

II.3 EQUIPMENT

a. Min. equipment

1. Airspeed indicator up to 300 km/h
2. Altimeter
3. Four-piece safety harness for front and rear seat
4. Seat cushions, at least 10cm thick when loaded, or parachutes (automatic or manual)
5. Weight and balance data placard (front and rear seat)
6. Data plate
7. Flight Manual

b. Equipment for aerobatics

For aerobatics the above min. equipment must be supplemented as follows :

1. Additional bottom strap for the safety harness
2. G-meter for front seat
3. Foot loops on rudder pedals
4. Parachute (automatic or manual)

c. Equipment for cloud flying

For cloud flying the above min. equipment must be supplemented as follows :

1. Variometer
2. Turn and bank indicator
3. Magnetic compass (compensated)
4. VHF transceiver radio

II.4 SPEEDS

Max speed calm air	$V_{NE} = ^*)280$ km/h (151 kts)
Max speed rough air	$V_B = 200$ km/h (108 kts)
Max maneuvering speed	$V_M = 180$ km/h (97 kts)
Max speed aerotow	$V_T = 180$ km/h (97 kts)
Max speed winch tow	$V_W = 150$ km/h (81 kts)

Rough air means turbulence found in wave-rotors, Cn-clouds, dust devils or when skimming mountain crests.

Maneuvering speed V_M is the highest speed at which full control deflections still may be applied.

With max speed V_{NE} only one third of the max possible deflections may be applied. One must also take into account that with increasing altitude the true airspeed is higher than the reading of the A.S.I. because of the decreasing air density.

True airspeed (TAS) is, however, relevant for safety against flutter.

*) The max indicated V_{NE} is reduced as follows according to altitude :

Altitude (M)	0-2000	3000	4000	5000	6000
V_{NE} indicated (km/h)	280	267	255	239	226

Altitude (ft)	5000	10000	15000	20000
V_{NE} indicated (kts)	151	144	132	121

The airspeed indicator must show the following color codes :

Green arc	80-180 km/h	(43- 97 kts)
Yellow arc	180-280 km/h	(97-151 kts)
Red radial line	at 280 km/h	(at 151 kts)
Yellow triangle	at 90 km/h	(at 48,5 kts)

II.5 LOAD FACTORS

The following load factors must not be exceeded :

at maneuvering speed V_M	+6,5	-4,0
at max speed V_{NE}	+5,3	-3,0
with airbrakes extended	+3,5	± 0

G-meter markings :

- a. positive range
 - yellow arc +5,3 to +6,5
 - red radial line at +6,5
- b. negative range
 - yellow arc -3,0 to -4,0
 - red radial line at -4,0

II.6 WEIGHTS

Empty weight	approx. 360kg	(792 lbs)
Max all-up weight	600kg	(1320 lbs)
Max weight of non lift producing members	410kg	(904 lbs)

II.7 IN FLIGHT C.G.

The in flight c.g. range is from 234mm to 469mm behind datum (9,21" to 18,46"); correspondingly 20,2 % up to 41,1 % of the mean aerodynamic chord,

$t_m = 1,121m$ (3'68") with $a = 8mm$ (0,32") behind wing leading edge; inner wing = datum point.

II.8 WEIGHT AND BALANCE INFORMATION

Min payload front seat	70kg	(154 lbs)
Max payload front seat	110kg	(242 lbs)
Max payload rear seat	110kg	(242 lbs)
Baggage in wingroots max	2 x 10kg	(2 x 22 lbs)

Neither the all up weight of 600kg (1320 lbs) nor the max weight of non-lift producing members + occupants & baggage of 410kg (904 lbs) must be exceeded.

The weight limitations on the basis of the last weighing are to be found on page 11 !

With this loading the in flight c.g. is in the permissible range.

Low weight in the front seat must be compensated by fixed ballast.

ASK 21 Flight Manual

II.8 cont. Weight and Balance Information / Minimum load in front seat

The minimum payload in the front is found on the weight and balance sheet on page 11.

CAUTION: *Short weight in the front seat must be compensated by ballast (installation of lead discs in the nose).
1 lead disc = 2.76 lbs pilot weight*

Number of lead discs	Results in a reduction of the minimum payload in the front seat of		If the minimum payload in the front seat is 70kg (154lbs), it changes to:	
	kg	lbs	kg	lbs
0	0	0.00	70	154.32
1	1.25	2.76	68.75	151.57
2	2.5	5.51	67.5	148.81
3	3.75	8.27	66.25	146.06
4	5	11.02	65	143.30
5	6.25	13.78	63.75	140.54
6	7.5	16.53	62.5	137.79
7	8.75	19.29	61.25	135.03
8	10	22.05	60	132.28
9	11.25	24.80	58.75	129.52
10	12.5	27.56	57.5	126.77
11	13.75	30.31	56.25	124.01
12	15	33.07	55	121.25

Concerning the minimum payload in the front seat, in addition the following applies: One third of the weight of the rear pilot contributes to the payload in the front seat.

But for pilot training it may be noted: If from the beginning the student forms a habit of installing the amount of lead discs he would also need for solo flying, fewer mishaps may arise later.

II. WEIGHT & BALANCE INFORMATION

Max. payload front seat (pilot incl. parachute): 242 lbs = 110 kg

Min. payload front seat (pilot incl. parachute): 154 lbs = 70 kg

Caution: Short weight in the front seat must be compensated by ballast (installation of lead discs in the nose;

1 lead disc = 2,76 lbs pilot weight).

Number of lead discs	Min. payload front seat	
	kg	lbs
0	70,0	154,32
1	68,75	151,57
2	67,5	148,81
3	66,25	146,06
4	65,0	143,30
5	63,75	140,54
6	62,5	137,79
7	61,25	135,03
8	60,0	132,28
9	58,75	129,52
10	57,5	126,77
11	56,25	124,01
12	55,0	121,25

Max. payload rear seat (pilot incl. parachute): 242 lbs = 110 kg.

1 kg = 2,2046223 lbs

Date of weight & balance	Empty weight c.g. (mm/in. behind datum)	Front seat kg/lbs payload incl.chute		Rear seat kg/lbs payload incl.chute		Signature of inspector, inspection stamp
		min	max	min	max	

11
 APRIL 1980
 11

II.9 TOW RELEASES

For aerotow : nose release E 75

For winch tow : safety release Europa G 73

II.10 WEAK LINK IN TOW ROPE

Aerotow max. 600 \pm 60 daN

Winch tow max. 1000 \pm 100 daN

II.11 TIRE PRESSURE

Main wheel 5.00-5 : 2,7 bar

Nose wheel 4.00-4 : 2,0 bar

Tail wheel 210x65 : 2,5 bar

II.12 CROSSWIND

The permissible crosswind component is about 15 km/h.
(8 knots).

III. EMERGENCY PROCEDURES

III.1 RECOVERY FROM SPIN

According to the standard procedure spinning is terminated as follows:

1. Apply opposite rudder (i.e. apply rudder against the direction of rotation of the spin).
2. Short pause (hold control inputs for about 1/2 spin turn).

Warning: Disregarding the pause will result in slower recovery!

3. Release stick (i.e. give in to the pressure of the stick) until the rotation stops and sound airflow is established again.

Warning: Full forward stick may retard or even prevent the recovery!

4. Centralise rudder and allow sailplane to dive out.
The altitude loss from the beginning of the recovery until the normal flight attitude is regained is about 80 meter (260 feet).

Note: During spins the ASK 21 oscillates in pitch. From a steep nose down spin recovery according to the standard procedure is up to 1 turn, from a flat spin less than 1 turn.

III.2 CANOPY JEETISONING AND EMERGENCY BAIL OUT

- Front canopy:
- a. Move lever with red knob above the instrument panel to the left and push canopy upwards.
 - b. Open safety harness.
 - c. Get up and bail out.
 - d. With manual chute seize release grip and pull out entirely after 1 to 3 seconds.

- Rear canopy :
- a. Pull back both canopy side locks and push canopy upwards.
 - b. Open safety harness.
 - c. Get up and bail out.
 - d. With manual chute seize release grip and pull out entirely after 1-3 seconds.

If circumstances allow, the front pilot should allow the rear pilot to bail out first.

III.3 FLIGHTS IN THE RAIN

With wet or slightly iced wings or insect accumulation there will be no deterioration in flight characteristics.

However, one has to reckon with a rather considerable deterioration in flight performance. This must be taken into account especially on landing final approach !!

Add a safety margin of 10 km/h (5,4 knots) for approach speed !!

III.4 WING DROPPING

The sailplane stalls extremely benign. Nevertheless one always has to face the possibility of wing dropping because of turbulence. In that case push stick forward immediately and apply opposite rudder against a noticeable turn at the same time to regain a normal flight attitude. If the rudder deflection against the turn is forgotten, a spin may occur even if the stick pressure is released.

III.5 GROUND LOOPING

For normal conditions, smooth runway, short grass, one may take off with the wing on the ground without having to fear a change in the direction.

High grass and rough ground, however, may cause ground looping. In that case release the tow rope immediately.

ASK 21 Flight Manual

IV. NORMAL OPERATION PROCEDURES

IV.1. COCKPIT AND OPERATING LEVERS

Front Seat:

- No.1. Stick.
- No.2. Trim; flat lever with green knob LH of stick.
- No.3. Rudder pedal adjustment; grey knob at the console.
- No.4. Airbrakes with wheelbrake; blue hand grip in the left arm rest.
- No.5. Release cable; yellow knob on the front left below the canopy frame.
- No.6. Canopy emergency jettisoning; horizontal lever with red flat knob above the instrument panel cover. To the left = "Open".
- No.7. Front canopy locking; white swivel levers on left & right canopy frame.
To open canopy: pull back both levers.
To lock canopy: push both levers forwards - parallel to the canopy frame.
- No.8. Ventilation nozzle; on right cockpit wall below canopy frame; adjustable and closable.
- No.9. Back rest; the back rest is adjustable by lifting it at the bottom upwards and forwards (see sketch). In normal flight attitudes the back rest cannot shift by itself. Very tall pilots may fly without the back rest.
- No.10. Trim indicator; in the right arm rest behind the ventilation nozzle.
- No.11. Detachable rudder hand lever at the left cockpit wall below the air brake grip (not figured): only applicable for mod TN no.25 dated 16.02.1993.

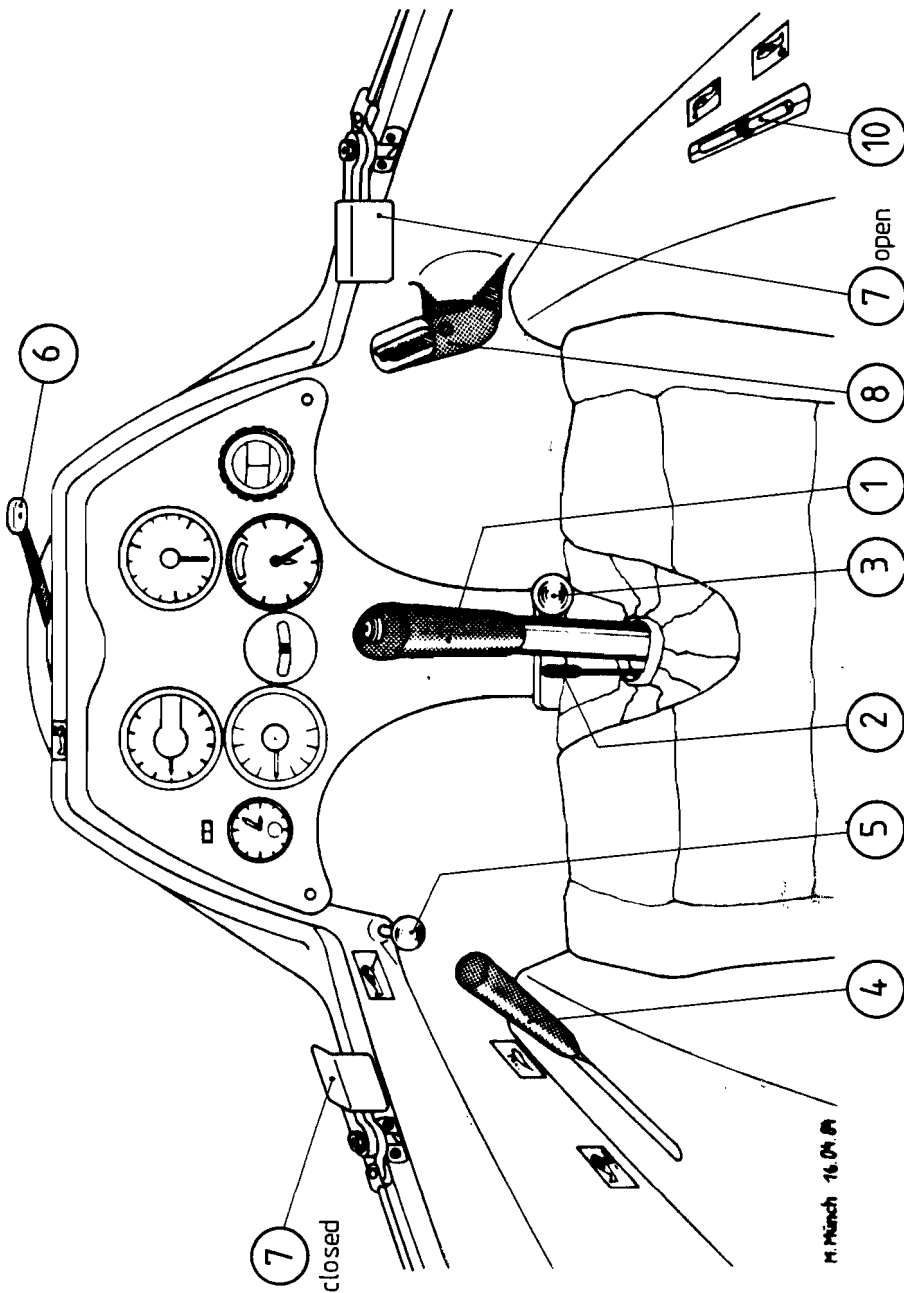

ASK 21 Flight Manual

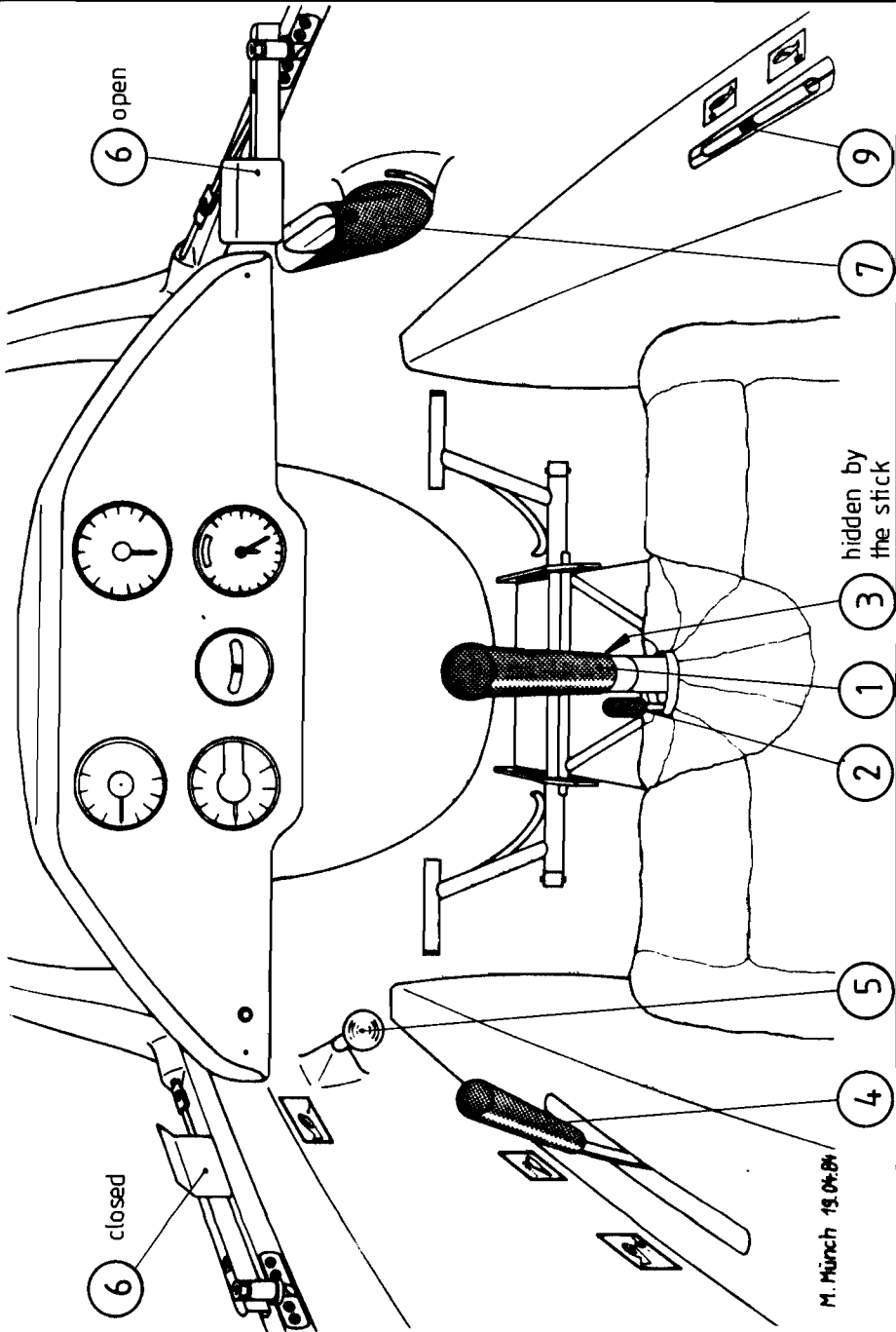

M. Münch 19.04.84

BACK REST ADJUSTMENT

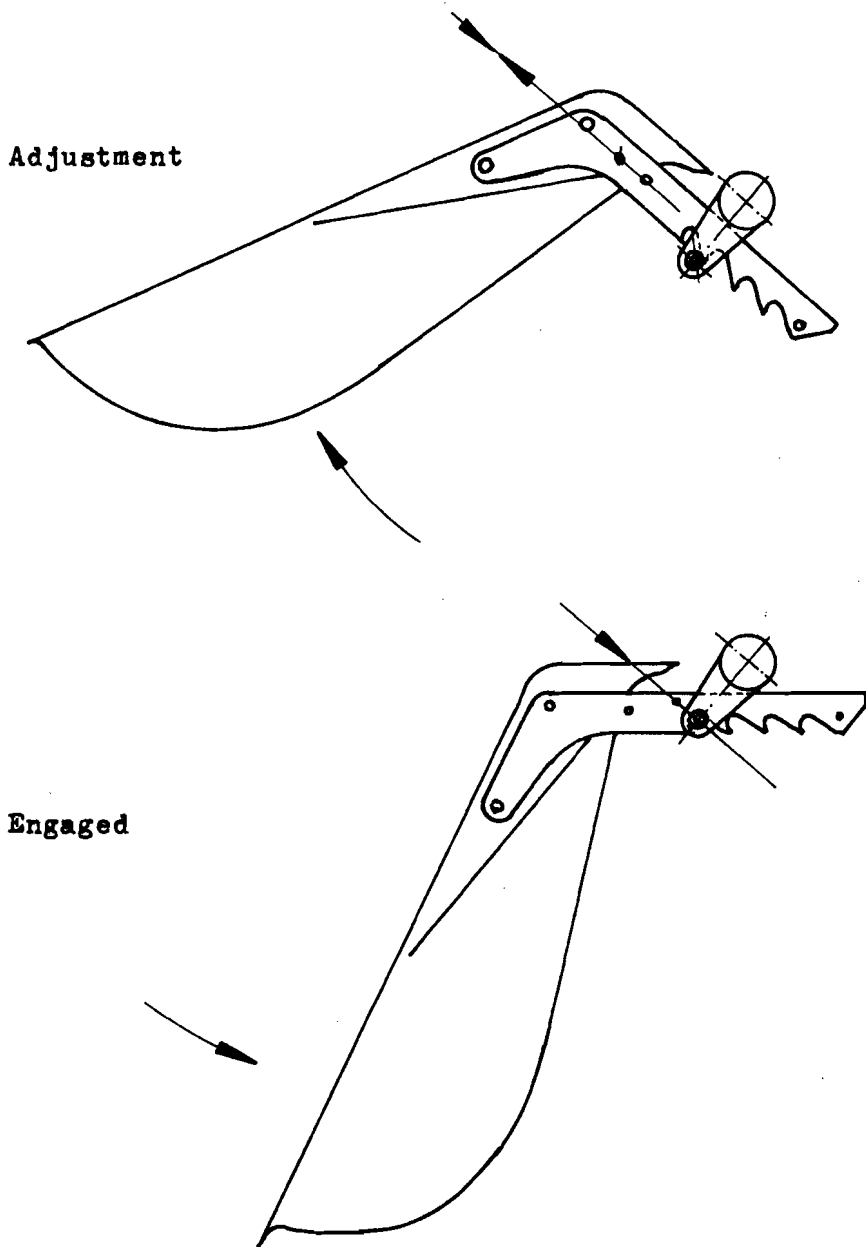

ASK 21 Flight Manual

IV.2 DAILY CHECKS

- 1.a) Open canopy! Check that the main pins are properly secured by the lock catches.
 - b) Check the proper connection of the ailerons and airbrakes through the access hole on the left side above the wing. Are the quick-release connectors secured with spring clips ?
 - c) Check for foreign bodies !
 - d) Check the control circuits force and that all controls are free-moving. Apply full deflections and load the control circuits with fixed controls and airbrakes. Check the plastic tubes inside the S-shaped tubes of the rudder pedals for proper and tight fit.
 - e) Check tire pressure:
Nose wheel 2.0 bar (28 psi)
Main wheel 2.7 bar (38 psi)
Tail wheel (if installed) 2.5 bar (35.6 psi).
 - f) The condition and function of the tow release mechanism is to be checked. Actuate the tow release: does it snap back freely ? Engage and disengage the ring pair. Check the automatic release of the C.G. towing hook with the ring pair which must release automatically backwards.
 - g) Check the wheel brake. Pull the air brake lever; at the end of its travel an elastic resistance must be felt.
 - h) Only in flight operation with the rudder hand lever: flanged bolt screwed in at the airbrake handle and secured? Rudder hand lever mounted and secured ?
- 2.a) Check upper & lower wing surface for damages!
 - b) Aileron: condition, freedom of movement, and play is to be checked ! Check also the push rod connection.
 - c) Airbrake: check condition, adjustment and good locking.
- 3.) Check the whole fuselage for damages, in particular the bottom side.
 - 4.) Check that the tailplane is properly assembled and secured. Check also the pushrod connection. Secured by spring clips?

Rev.No./Date. Sig.
TN25 /16.02.93 Juw

Author Date
Kaiser April 80

Page No.
21

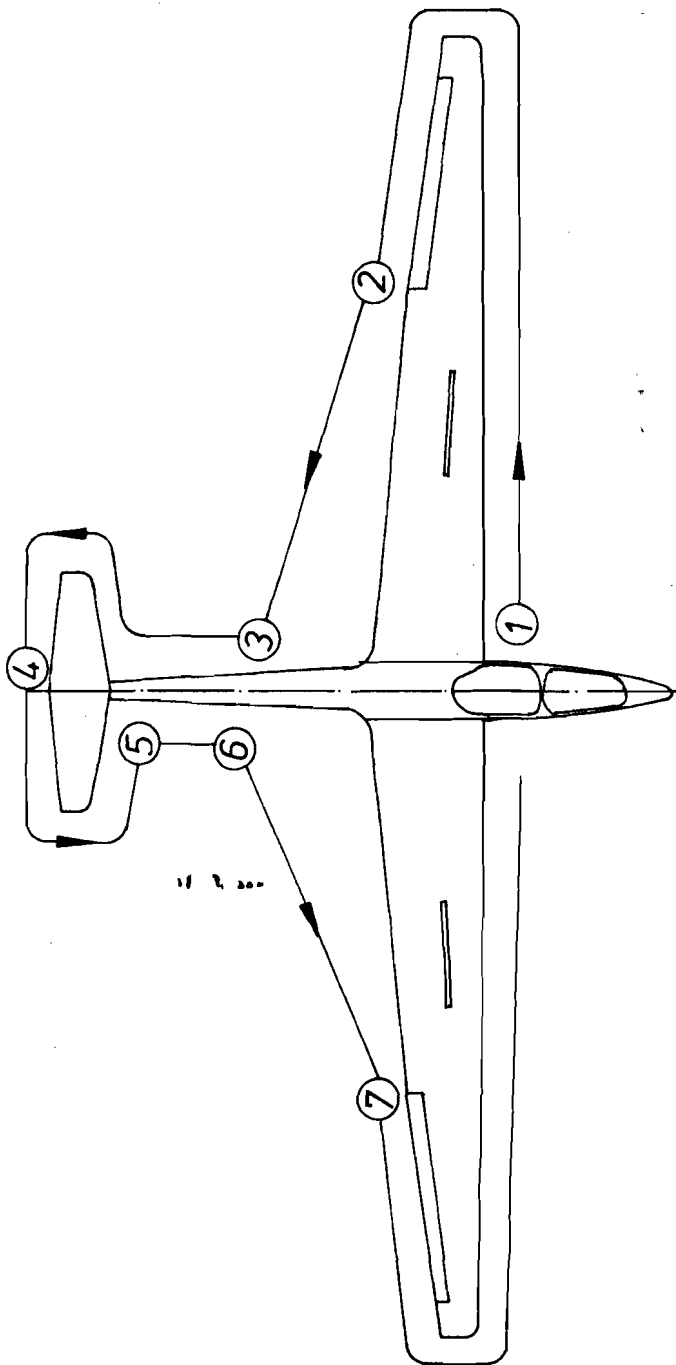

DAILY CHECKS (see IV.2)

5. Check condition of tailskid, pitot tube and venturi tube !
6. Check static vents for cleanness !
7. See 2.

After rough landings or excessive flight stress the whole sailplane must be checked with the wings and tail unit removed. If any damage is found, a technical inspector must be called in. On no account one must take off again before the damage has been repaired.

See also Maintenance Manual !!

IV.3 PRE TAKE OFF CHECK

1. Controls easy to operate ?? (Control circuits check done ??)
2. Airbrakes locked ??
3. Trim neutral ??
4. Canopy locked ?? Pay especially attention to the rear canopy !
5. Safety harness and parachute fastened ?? (Parachute static line engaged with automatic parachute ??)
6. Altimeter adjusted to field height or to zero ??
7. Radio "on" and adjusted to proper frequency ??

IV.4 TAKE OFF

Winch tow :

Trim neutral.

Max tow speed : 150 km/h (81 kts).

The sailplane features a tow release for winch tow in front of the main wheel.

The most favorable tow speed is 90 - 110 km/h (49 - 60 kts).

There is little pitch up tendency during the initial tow. In the upper third of the tow additional altitude may be gained by slight back pressure.

Tow release : pull the release knob to the stop several times.

Aero tow :

Aero tows only with the nose release in front of the nose wheel.

Recommended tow rope length : 30-60 m (98-197 ft); textile rope.

Trim neutral.

Max tow speed : 180 km/h (97 kts).

The most favorable tow speed during climb is 90 - 140 km/h (49 - 76 kts).

Take off may be done with the wingtip on the ground. Getting the wings level is no problem. However, the pilot is advised to be careful with high grass and very rough ground.

Take off takes place at about 75 km/h (40 kts).

IV.5 FREE FLIGHT

The sailplane may be flown up to $V_{NE} = 280$ km/h (151 kts), see p.8. Up to manoeuvring speed of 180 km/h (97 kts) full control deflections can be applied. At higher speeds the controls must be applied more carefully.

At V_{NE} only 1/3 of the max. possible deflections must be applied.

IV.6 LOW SPEED FLIGHT, WING DROPPING AND SPINS

With the stick back a distinct tail buffet is felt.

The sailplane is very benign in low speed flight. By use of normal aileron deflections the wings may be kept level down to minimum speed, even with aft C.ofG.-positions.

With normal rudder deflections no wing dropping is found. Yaw angles of up to 5° have no significant influence on the wing dropping attitude.

Also rapid pulling up into 30° pitch does not cause wing dropping, but only a gentle nose drop. The same applies for stalling out of a 45° turn.

But one has to point out that even the most benign sailplane needs speed in order to be controllable.

In turbulence this is especially important when also a wing dropping may occur.

Spin development from wing dropping strongly depends on the C.ofG. position and also to some extent from the pilot reaction.

For C.ofG.positions forward of 315 mm aft of datum the ASK 21 does not spin at all. This configuration applies to 2 heavy pilots.

For C.ofG.-positions from 320 mm through 385 mm aft of datum, more incipient spin turns are possible followed by self recovery after 4 1/2 turns at most. Such C.ofG.-positions are possible in dual flight with a lightweight pilot in the front seat.

For C.ofG.-positions aft of 400 mm behind datum controllable sustained spins are possible. Such a C.ofG.-position is usually only possible with one lightweight pilot in the front seat.

Note: During spins the ASK 21 oscillates in pitch. From a steep nose down spin recovery according to the standard procedure is up to 1 turn, from a flat spin less than 1 turn.

The speed at which the stall takes place depends on the payload. The following standard values are applicable:

Single: All up weight 470 kg (1034 lbs):
 without airbrakes 65 km/h (35 kts) IAS
 with airbrakes 68 km/h (37 kts) IAS

Dual: All up weight 600 kg (1320 lbs):
 without airbrakes 74 km/h (40 kts) IAS
 with airbrakes 77 km/h (42 kts) IAS

IV.7 HIGH SPEED FLIGHT

The sailplane shows no flutter tendency within the permissible speed range.

With airbrakes extended in a 45° dive the speed remains below V_{NE} = 280 km/h (151 kts); it goes up to 232 km/h (125 kts) at $G = 600$ kg.

IV.8 CLOUD FLYING

For min. equipment for cloud flying see II.3 a and II.3 c.

According to past experiences the airspeed indicator system is not exposed to the danger of icing-up. However with strong icing-up the pilot must be always take into account the possible failure of the airspeed indicator. When planning cloud flying, he must take this point into consideration.

Excessive speeds during cloud flying must be avoided in any case. The pilot should try to keep an average speed of about 100 km/h (54 kts) and with increasing speed above 130 km/h (70 kts) he should use the airbrakes in order to control the speed.

Attention !!

Cloud flying must only be done by pilots having the necessary licence. The legal regulations with regard to airspace and the requirements for instruments have to be met.

IV.9 AEROBATICS**Attention aerobatic flyers !!**

Even a sailplane which is approved for full aerobatics does not have infinite strength capacities. Most hazardous are aerobatics which get out of control or are badly executed, as they result in the high loads.

Therefore, it is urgently recommended to have oneself guided by an experienced flight instructor. The ASK 21 being an approved two-seater for full aerobatics offers this possibility.

Such guidance is even prescribed according to §69 (4) of the German 'LuftPersPO' (Aviation Personnel Test Regulations) dated January 9, 1976. Following §96 (3) of the said 'LuftPersPO' an adequate experience is required from flight instructors.

Note !!

The normal airspeed indicator system shows a large pressure error in inverted flight during which the airspeed indicator reads 40 km/h (22 kts) too low. When extending the pitot head by attaching a brass tube - 12~~0~~ x 1; 140mm (5,5 in) in length -, this error disappears. The tube must project in the front at least 70mm (2,75 in). For normal flights this is not necessary. In order to avoid damage when parking the sailplane in the hangar, this tube should not be left on any longer than necessary.

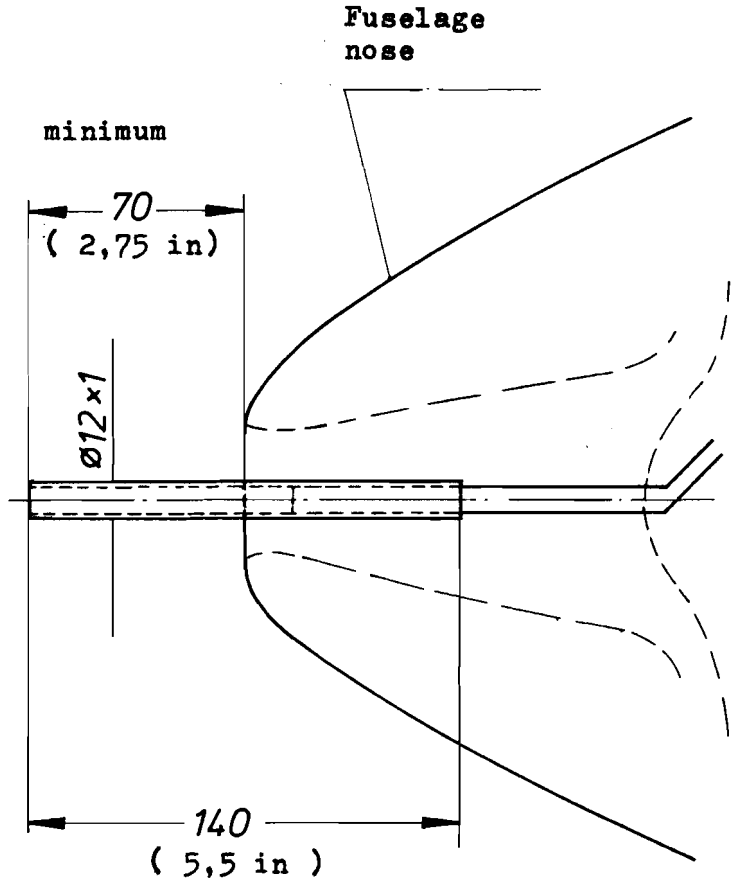

Extension tube for total pressure head with inverted flight. Brass tube 140 mm (5,5 in) in length (12 Ø x 1).

One may also use a suitable plastic tube provided that it is sufficiently stiff and straight.

ASK 21 - Flight Manual

For the aerobatics hereafter mentioned the following entrance speeds are recommended :

	Indicated Entrance speed	Max Acceleration
Loop upward	single : 155km/h (84 kts)	2 - 3 g
	dual : 170km/h (92 kts)	
Stall Turn	single : 165km/h (89 kts)	3 g
	dual : 180km/h (97 kts)	
Split 'S'	single : 170km/h (92 kts)	2 - 3 g
	dual : 180km/h (97 kts)	
Immelmann	single : 165km/h (89 kts)	2,5 - 3,5g
	dual : 180km/h (97 kts)	
Slow Roll	single : 150km/h (81 kts)	
	dual : 165km/h (89 kts)	
Steep Climbing)		
Turns and Lazy Eight	single : 140km/h (76 kts)	
	dual : 150km/h (81 kts)	
Chandelle	single : 160km/h (86 kts)	
	dual : 175km/h (95 kts)	

Permissible Indicated Speeds

Inverted flight without pitot head extension :

V_{NE}	single	65-240 km/h (35-130 kts)
	dual	70-240 km/h (38-130 kts)

Indicated maneuvering speed	V_M	= 140 km/h (76 kts)
Indicated max speed	V_{NE}	= 240 km/h (130 kts)

Inverted flight with pitot head extension :

Indicated maneuvering speed	V_M	= 180 km/h (97 kts)
Indicated max speed	V_{NE}	= 280 km/h (151 kts)
Indicated stall speed		= 87 km/h (47 kts)
		with two occupants

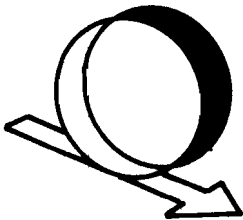

LOOP

Entrance speed :

single : 155 km/h

dual : 170 km/h

max. g = 2 - 3

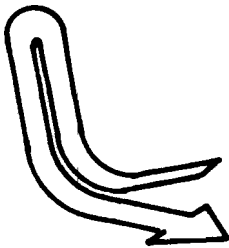

STALL TURN

Entrance speed :

single : 165 km/h

dual : 180 km/h

max g = 3

SPLIT 'S' ,

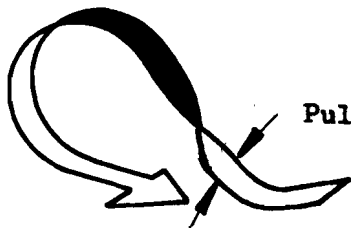

Pull-up at least 30° !

Altitude loss approx. 100 meter

Entrance speed :

single : 170 km/h

dual : 180 km/h

max. g = 2 - 3

IMMELMANN

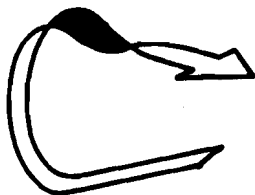

Entrance speed :

single : 165 km/h

dual : 180 km/h

max. g = 2,5 - 3,5

SLOW ROLL



Entrance speed :

single : 150 km/h

dual : 165 km/h

INVERTED FLIGHT



HALF LOOP

HALF ROLL

Note : with the inverted flight the fuselage nose will be unexpectedly high above the horizon.

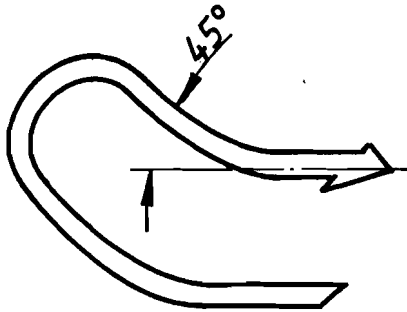

STEEP CLIMBING TURN

Entrance speed :

single : 140 km/h

dual : 150 km/h

CHANDELLE

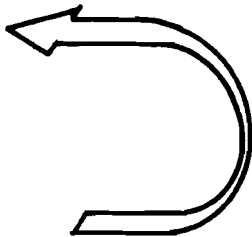

Entrance speed :

single : 160 km/h

dual : 175 km/h

Attention !!

Never release stick and rudder pedals when flying aerobatics.

With aerobatics instruction a reliable agreement must be made between instructor and student flyer with regard to the communication system for the mutual taking over of the controls.

Airbrakes must be extended as soon as the pilot loses the control of the sailplane or as the speed increases unvoluntarily too rapidly.

Exception : "Tail sliding" !!

The trim remains in the center position for aerobatic maneuvers. Don't ever change the trim when flying aerobatics !!

PROHIBITED AEROBATICS :

All abrupt aerobatic maneuvers.

Loop forward.

Tail sliding.

IV.10 APPROACH AND LANDING

The most favorable approach speed is about 90 km/h (49 kts). With turbulence it may be advisable to increase the approach speed slightly. Even steep approaches may be slowed down efficiently with the airbrakes. It is advisable to unlock the airbrakes at the beginning of the landing final approach.

Note : The airbrakes increase the stalling speed by about 3 km/h (1,6 knots).

Sideslipping is also suitable as an approach control.

With full rudder during sideslipping the rudder pressure decreases to zero; the rudder must be pushed back.

V. RIGGING AND DE-RIGGING

V.1 RIGGING

Rigging the ASK 21 can be carried out by four persons without mechanical assistance, and by three persons with the use of a fuselage stand or a wing support.

Prior to rigging, clean and grease all pins, bolts, bushings and control system connections !

1. Set up the fuselage and hold it horizontal.
2. Plug the spar fork of the left wing into the fuselage and - if available - place a wing support under the wing end.
3. Offer up the right wing and align the main pin fittings.
4. Press in the main pins and secure. Never insert the rear wing attachment pins prior to the main pins !
5. Press in the rear wing attachment pins; unscrew the T-tool and check whether the safety lock is engaged.
6. Connect and lock the aileron control linkages in the fuselage behind the spar tunnel. You must be able to touch the ball pivot by feeling through the slot in the socket. Also check the proper engagement of the safety lock by pushing it on to close ! Secure them with spring clips!
7. Connect and lock the airbrake control linkages in the fuselage behind the spar tunnel. Secure them with spring clips!

8. The tailplane is fitted onto the fin from the front (see Fig. V.2-1 and V.2-2).
Now the Allan bolt at the leading edge is screwed in; this should be screwed in tightly until the spring-loaded safety pin snaps out over the screw head as far as the socket.

9. Connect the elevator and safety with a spring clip !

Note, if your glider uses an automatic elevator connection: after cleaning and lightly greasing the plug-in elevator connections, the tailplane is fitted onto the fin from the front; both elevator panels must be fitted into their connectors simultaneously. Then the tailplane is pushed back until the Allan bolt at the leading edge can be screwed in; this should be screwed in tightly until the spring-loaded safety pin snaps out over the screw head as far as the socket.

10. Carry out a pre-flight check referring to the Check List.

11. The control circuits must be subjected to an operational test.

12. Check condition and function of the wheel brake; check the tire pressure.
See also Section IV.2 Daily Inspections.

Rev. no.	Date	Sig.	
TN 22	26.11.90	Juw	

Author	Date		
Ka. Juw	16.10.87		

Page no.
36 b

V.2 DE-RIGGING

De-rigging is carried out in the reverse sequence to that of rigging. It must be taken care that the rear wing attachment pins have to be removed prior to the main pins.

WARNING: For derigging the horizontal tail from the fin it has to be regarded hat only the method according to Fig. V.2-2 is used.

Fig. V.2-1
WRONG: Twist movement

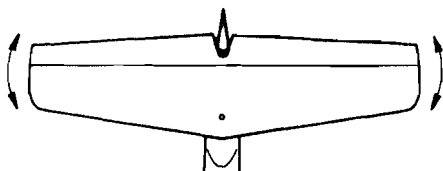
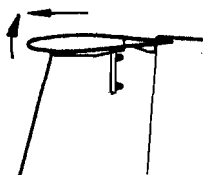

Fig. V.2-2
RIGHT: Pitch movement



V.3 PARKING

When parking the glider, the canopies have to be closed.

When an ASK 21 is parked on an airfield in the sunshine (this must also be observed during the waiting time until take-off when the pilots are already on board) the canopies must not be left open for some time.

Depending on the position of the sun and the intensity of the radiation, the burning-glass effect of the canopies can cause a slow fire in the area of the instrument panel or the headrest respectively.

Therefore, if you have to store the glider outside, it is absolutely necessary always to close the canopies and to cover them with a white cloth.

V.4 ROAD TRANSPORT

The design of a glider trailer is another subject and cannot be discussed in all details here. Of course, a closed trailer is preferable. But also an open trailer may serve the purpose, the latter is generally simpler and lighter. It is important that all components are well fixed and have a large support surface.

Structural components survey drawing which can be used for the building of a trailer, can be obtained from ALEXANDER SCHLEICHER.

WARNING: In no case must the elevator actuator fitting be loaded. This fitting trades out of the upper end of the fin. Not even soft foam cushions are allowed.

For the construction of the trailer for road transport the full freedom from any load must be carefully regarded.

V.5 PREVENTIVE MAINTENANCE

The whole surface of the sailplane is painted with a weather resisting, white polyester coat.

Impurities may be washed off with a mild cleansing agent. Heavy impurities may be removed with a polish.

For the paint maintenance only silicone-free agents are to be used (e.g. 1 Z-special cleansing agent-D2 from the company W.Sauer & Co., 5060 Bensberg, W. Germany, or the cleansing polish from the company Lesonal). Though the sailplane is rather insensitive, it should be protected as much as possible against moisture and humidity. If water has soaked into any components, these have to be stored in a dry room and must be turned over frequently.

The canopy is best cleaned with a special plexi-glass cleansing agent, in an emergency lukewarm water will do. Rewipe only with pure, soft leather or with glove cloth. Never wipe on dry plexiglass.

The safety harnesses must be regularly checked for damage and tears. The metal parts of the harnesses must be checked for corrosion.

POSITION ERROR

With normal flights the position error of the airspeed indicator is negligible within the whole range up to 280 km/h (151 kts).

With inverted flights the airspeed indicator reads too low, i.e. up to -40 km/h (22 kts).

By attaching an extension tube this error may be eliminated. (see also pages 27/28).

The extension tube must project at least 70 mm (2,75 in) past the fuselage nose.

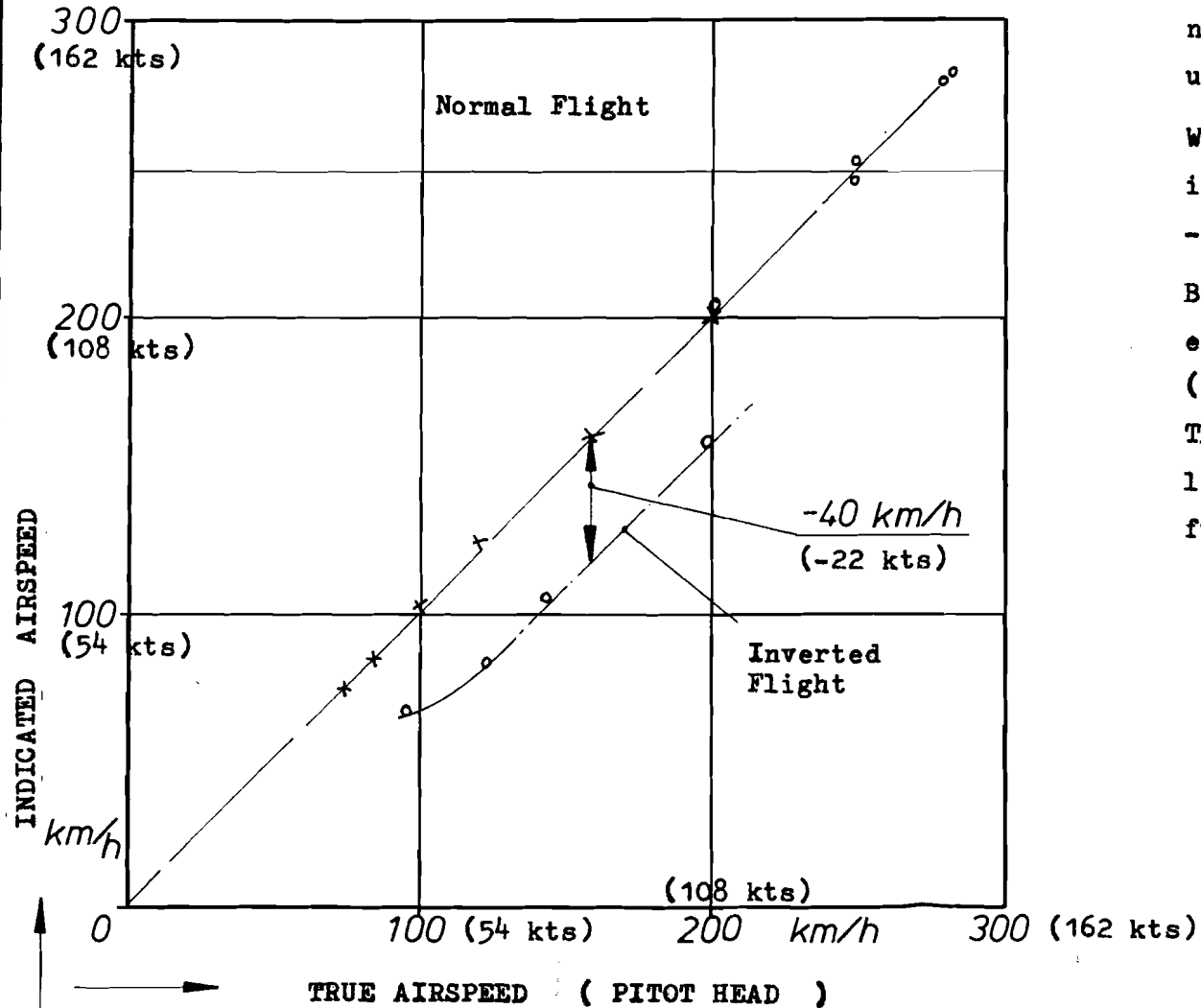

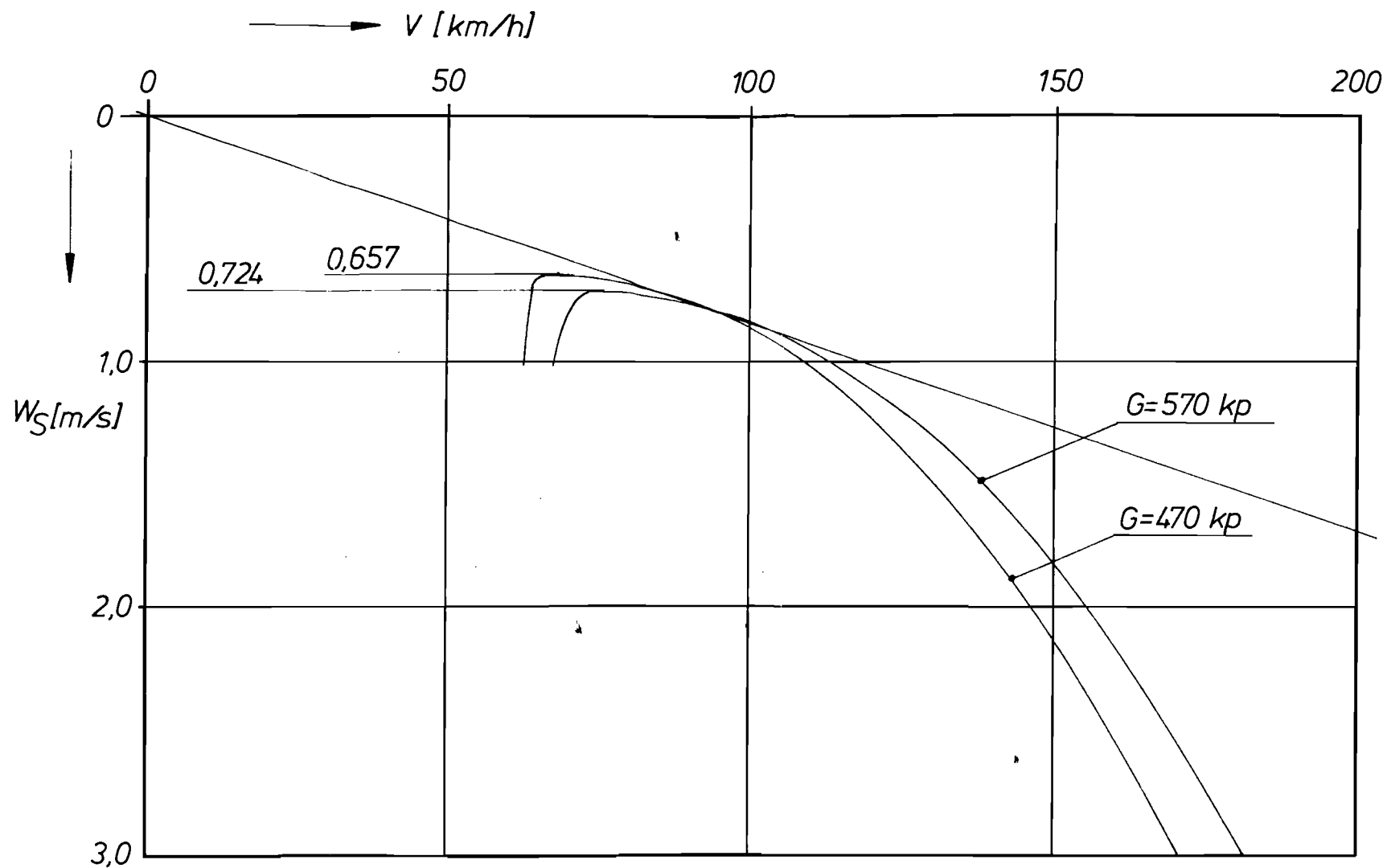

- Ⓜ Clean and lubricate prior to every rigging.
- Disassemble and lubricate on annual inspection.

Lubricate grease nipples if required, but at least once a year.

Clean and oil the tow releases if required.

Cleanse the ball bearings with gasoline and regrease them on annual inspection.

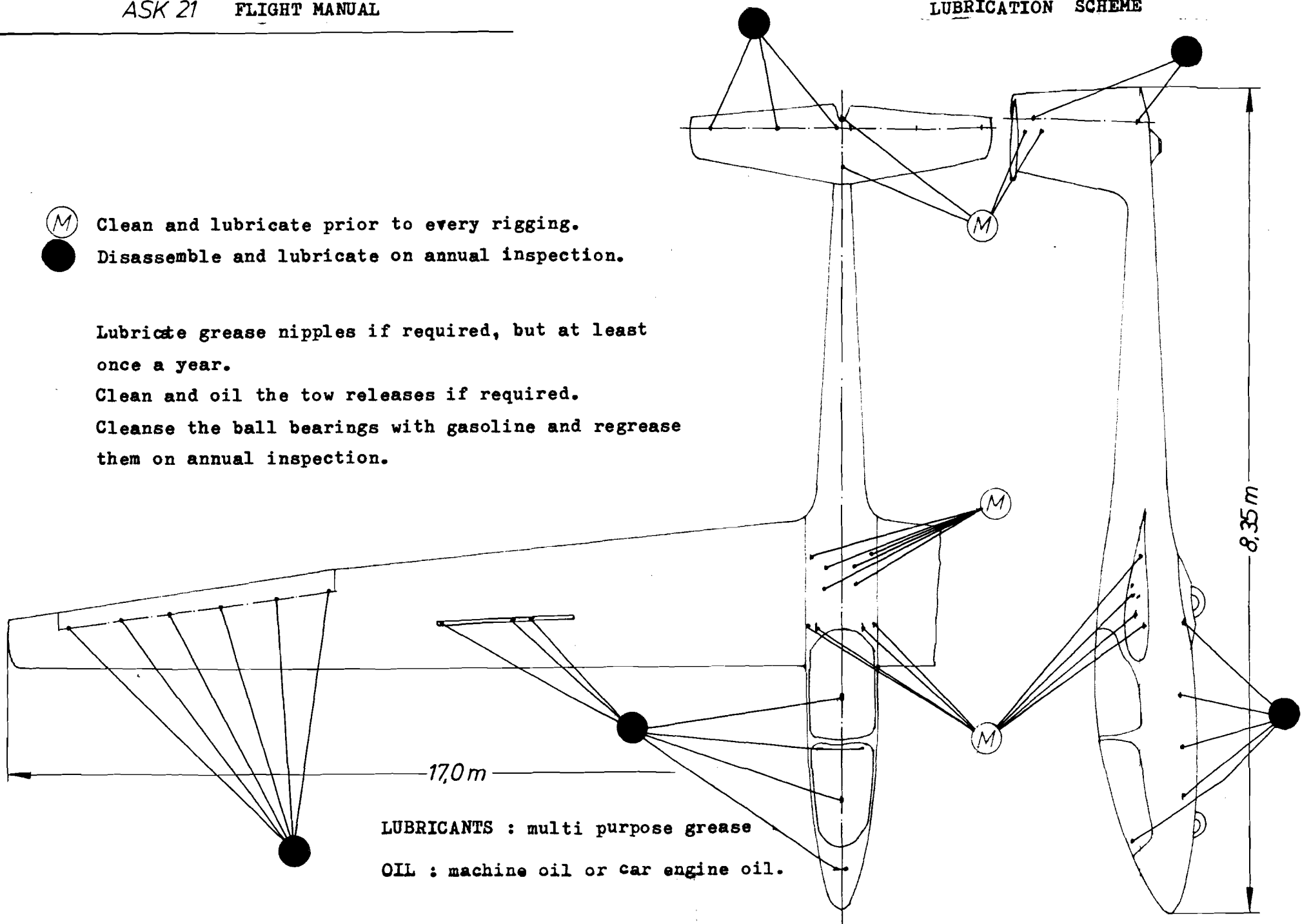

LUBRICANTS : multi purpose grease

OIL : machine oil or car engine oil.

SHEET:
1 of 1

**Technical Note
for**

**Alexander Schleicher
GmbH & Co.
Segelflugzeugbau
D-6416 Poppenhausen**

Glider model:

ASK 18, ASK 18B	TN-No. 7
ASW 19, ASW 19B	TN-No. 23
ASW 20/20L, ASW 20B/20BL, ASW 20C/20CL	TN-No. 34
ASK 21	TN-No. 21
ASW 22	TN-No. 6
ASK 23, ASK 23B	TN-No. 7
ASH 25,	TN-No. 4

Subject: New production series tow release couplings for aerotow and winch launch.

Serial number applicability:

ASK 18/18B,	Data Sheet No. L-307,	all serial no.s
ASW 19/19B,	Data Sheet No. L-308,	all serial no.s
ASW 20/20L,	Data Sheet No. L-314,	all serial no.s
ASW 20B/20Bl,	Data Sheet No. L-314,	all serial no.s
ASW 20C/20CL,	Data Sheet No. L-314,	all serial no.s
ASK 21,	Data Sheet No. L-339,	all serial no.s
ASW 22,	Data Sheet No. L-351,	all serial no.s
ASK 23/23B,	Data Sheet No. L-353,	all serial no.s
ASH 25,	Data Sheet No. 04.364,	all serial no.s

Compliance: None; applicable to new built gliders and in case of replacement of tow release couplings.

Reason: According to the company TOST they have stopped the previous production series of the tow release couplings "Nose tow release coupling E 72/75" and "Safety tow release coupling G 72/73". These have been replaced by the new tow release coupling productions series "Nose tow release coupling E 85" and "Safety tow release coupling Europa G 88". In order to guarantee a problem-free exchange of the previous productions series against the new one, the new tow release couplings show externally almost no differences.

Action:

1. Where replacement is required or where a corresponding installation location is provided the new tow release coupling production series can be installed instead of the previous ones.
2. When this mod is accomplished, a copy of this Technical Note must be inserted as Annex into the Flight and Maintenance Manual of the glider (Operations Manuals respectively). The accomplishment of this action must be entered into the corresponding table in the manuals (the table headline reads: Additions to . . . , Amendments to . . . , Record or Log of Revisions ..).

Notes: The glider owners must regard the "Operating and Maintenance Instructions" for the new production series tow release couplings issued by TOST and giving the service time until the next overhaul !

Poppenhausen, January 17, 1990

ALEXANDER SCHLEICHER

GmbH & Co.
i.A. *[Signature]*
Lütz-W. Juntow.

The German original of this Technical Note has been approved by the LBA under the date of March 1, 1990 (signature: SCHMALJOHANN). The translation into English has been done by best knowledge and judgement; in any case of doubt the German original is controlling.

Weisgabe sowie Verwendung dieser Unter-
lagen ist ohne schriftliche Genehmigung
gestattet, soweit nicht ausdrücklich zugestanden.
Zusammenhang, verlinkten zu. Schadens-
ersatzansprüche für den Fall der Patentletzung
oder Gebrauchsmuster-Eintragung vorbehalten



**Airworthiness
Directive
1993-001/3**

Luftfahrt-Bundesamt
Airworthiness Directive Section
Lilienthalplatz 6
38108 Braunschweig
Federal Republic of Germany

L'Hotellier ball and socket connectors

Effective Date: April 09, 1998

Affected:

Kind of aeronautical product:	Aircraft
Manufacturer:	L'Hotellier
Type:	L'Hotellier ball and socket connectors with lock plates
Models affected:	ball and socket connectors <u>with lock plates</u>
Serial numbers affected:	all
German Type Certificate No.:	none

Subject:

L'Hotellier ball and socket connectors with lock plates if installed in sailplanes, powered sailplanes and aeroplanes

Reason:

Reported incidents involving L'Hotellier ball and socket connectors have prompted the LBA to have investigations made as to the operational safety of L'Hotellier ball and socket connectors.

The results have shown that the friction surfaces of the lock plates will be run in and smoothed after a relatively small number of operations. As has been demonstrated in the tests, in this case even normal operating conditions are sufficient under unfavourable circumstances to surmount the static friction (i.e. the lock plates open).

The a.m. airworthiness deficiency may result in inadvertent disconnect of the L'Hotellier ball and socket connectors and thus to considerable operational malfunctions.

Controllability of the aircraft may be affected or even lost so that the defect may lead to an accident.

The reason for the issue of the second edition in April 1994 was the revision of the L'Hotellier instruction for Maintenance by which the roundness tolerance of the ball was increased from max. 0.05 mm to 0.1 mm.

The ball and socket connectors are to be secured by means of safety pins, Uerlings sleeves or Uerlings type sleeves.

This AD has been issued as a result of several occurrences with Uerlings type sleeves. For well-founded reasons, especially these sleeves are to be inspected for absence of cracks and sufficient self-locking ability and, if necessary, are to be replaced.

Action:

The Luftfahrt-Bundesamt emphasizes the fact that all pilots have to familiarize themselves with the particularities of L'Hotellier connectors, especially with the different locking systems and their handling.

The ball and socket connectors with lock plates are to be secured. For this purpose, the following actions are to be accomplished:

1. Safety pins (e.g. L'H 140-31 made by Hotellier), have to be retrofitted, if not yet installed. In certain cases, it may become necessary to re-bore the hole in the lock plate, which is provided for visual inspection, to \varnothing 1.2 mm so that the safety pin can be inserted (see attachment section I).

The use of a safety pin can be waived if the L'Hotellier ball and socket connector is already equipped with an approved locking system (e.g. Uerlings type sleeve, LS locking sleeve, Schempp-Hirth spring or Wedekind locking system) or if such a system is to be installed.

LBA approved locking systems: see attachment section II.

Uerlings type sleeves (specification number SE-001/78) as well as LS locking sleeves can only be used for straight joints and transmissions, but cannot be used for 90° joints.

Inspection of Uerlings Type Sleeves



**Airworthiness
Directive
1993-001/3**

Luftfahrt-Bundesamt
Airworthiness Directive Section
Lilienthalplatz 6
38108 Braunschweig
Federal Republic of Germany

Inspection of these sleeves for the absence of cracks and sufficient locking force (self-locking ability), replacement of the sleeves, if necessary (see attachment part III).

Installation information:

The sleeves have to be slid axially onto the L'Hotellier ball and socket connector, they may by no means be clipped radially onto the L'Hotellier ball and socket connector. Radial clipping (excessive opening of the sleeve) may lead to cracks or ruptures due to overstressing so that the sleeve cannot function properly any more.

Annual inspection of sleeves :

The sleeves shall be inspected at least once a year for the absence of cracks and sufficient locking force (self-locking ability). In the original specification for the Uerlings sleeves a biannual replacement interval is assumed. Deviations from this provision are stated in the technical information by the manufacturers.

2. Flight Manual

a) Section "Rigging"

The recommendation : „The lock plate of L'Hotellier ball and socket connectors should be secured"... given in several Flight Manuals in the a.m. or in a similar form is to be deleted and to be replaced by the following sentence:

"The L'Hotellier ball and socket connector must be secured."

b) If older Flight Manuals do not contain information about L'Hotellier ball and socket connectors, section IV (see attachment) is to be included in the Flight Manual under the Section "Rigging", if the L'Hotellier connector is or is to be secured by means of a safety pin. If necessary, the entry is to be included on a new page.

c) If Uerlings type sleeves are used as additional locking systems for L'Hotellier connectors, section III of the attachment is to be included in the Flight Manual.

These entries in the Flight Manual may be hand-written or inserted as a copy indicating the AD-No. 1993-001/3 in the Flight Manual.

The amendment is to be entered in the list of effective pages indicating the AD-No. 1993-001/3.

3.

Maintenance Manual

The enclosed Instructions for Maintenance (L'Hotellier, issue E 03/94) become herewith part of the operating instructions and are to be included in the aircraft Maintenance Manual - as far as this has not been done already by the manufacturers of the sailplanes, powered sailplanes, and aeroplanes concerned.

4.

All L'Hotellier ball and socket connectors are to be inspected in accordance with the above Instructions for Maintenance. Connectors exceeding the allowable tolerances are to be replaced.

Note:

Type-related technical information already published by the manufacturer or by the product support organisation for L'Hotellier ball and socket connectors become part of this AD.

The safety pins are available from:

- L'Hotellier safety pin, reference no. L'H 140-31
- safety pin \varnothing 1.2 mm, Ford reference no. 1473 931 (worldwide)
- manufacturers or product support organisations for the sailplane, powered sailplane or aeroplane types concerned

Compliance:

Locking of L'Hotellier connectors:

- on sailplanes and powered sailplanes not later than April 30th, 1994.
- on aeroplanes not later than May 15th, 1998.

Inspection of the Uerlings type sleeves on all aircraft:

Enquiries regarding this Airworthiness Directive should be referred to Mr. Olaf Schneider, Airworthiness Directive Section at the above address, fax-no. 0049 531/2355-254. Please note, that in case of any difficulty, reference should be made to the German issue!



**Airworthiness
Directive
1993-001/3**

Lufffahrt-Bundesamt
Airworthiness Directive Section
Lilienthalplatz 6
38108 Braunschweig
Federal Republic of Germany

With the next annual inspection but not later than May 15th, 1998, and thereafter at least once a year.

Technical publication by the manufacturer:

-none-

Accomplishment and log book entry:

Action to be accomplished by an approved maintenance organisation and to be checked and entered in the log book by a licensed inspector.

Note:

This AD supersedes the AD-No. 1993-001/2 dated April 20, 1994.

Holders of affected aircraft registered in Germany have to observe the following:

As a result of the a.m. deficiencies, the airworthiness of the aircraft is affected to such an extent that after the expiry of the a.m. dates the aircraft may be operated only after proper accomplishment of the prescribed actions. In the interest of aviation safety outweighing the interest of the receiver in a postponement of the prescribed actions, the immediate compliance with this AD is to be directed

Instructions about Available Legal Remedies:

An appeal to this notice may be raised within a period of one month following notification. Appeals must be submitted in writing or registered at the Lufffahrt-Bundesamt, Lilienthalplatz 6, 38108 Braunschweig.

Attachment to Airworthiness Directive No. 1993-001/3
L'Hotellier ball and socket connector, lock plate

Attachment page 1 of 4

Section I

L'Hotellier ball and socket connectors with lock plate

If the connectors are not yet equipped with safety pins (e.g. l'H 140-31 made by Hotellier), these safety pins have to be retrofitted. In certain cases it may become necessary to rebores the hole in the lock plate, which is provided for visual inspection, to $\varnothing 1.2$ mm so that the safety pin can be inserted.

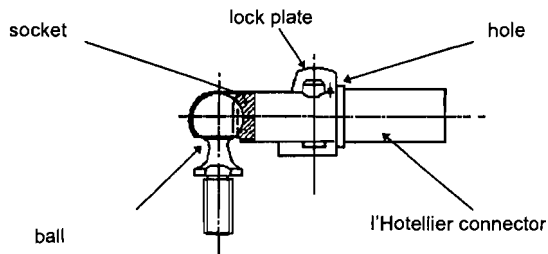

Warning!
Unsecured ball and socket connectors may open automatically in flight!

Attachment to Airworthiness Directive No. 1993-001/3
L'Hotellier ball and socket connector, lock plate
Attachment page 2 of 4

Section II

LBA-approved locking systems

The following systems to secure l'Hotellier ball and socket connectors are LBA-approved: Uerlings sleeves or Uerlings type sleeves (see section III), safety pin (figures 2 and 2a), LS-safety sleeve (figure 3), Schempp-Hirth spring (figure 4) und Wedekind locking system (figure 5).

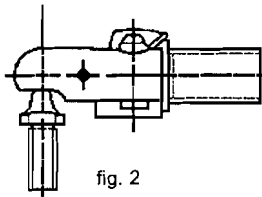

fig. 2

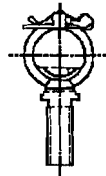

fig. 2a

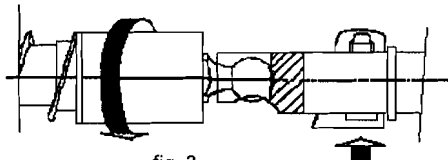

fig. 3

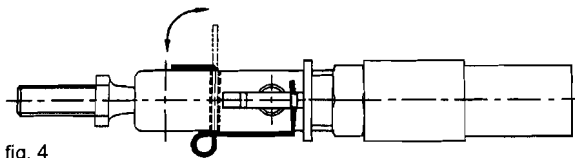

fig. 4

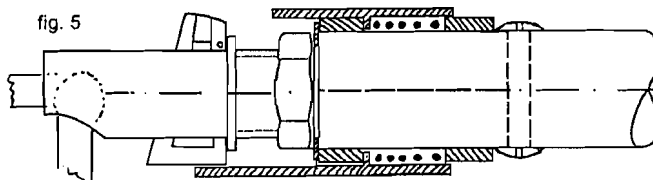

fig. 5

Attachment to Airworthiness Directive No. 1993-001/3
L'Hotellier ball and socket connector, lock plate
Attachment page 3 of 4

Section III

Installation instruction for Uerlings type sleeves

For installation, the sleeves have to be slid axially onto the l'Hotellier ball and socket connectors.

They may by no means be clipped radially onto the l'Hotellier ball and socket connector. Radial clipping (excessive opening of the sleeve) may lead to cracks or ruptures due to overstressing so that the sleeve cannot function properly any more.

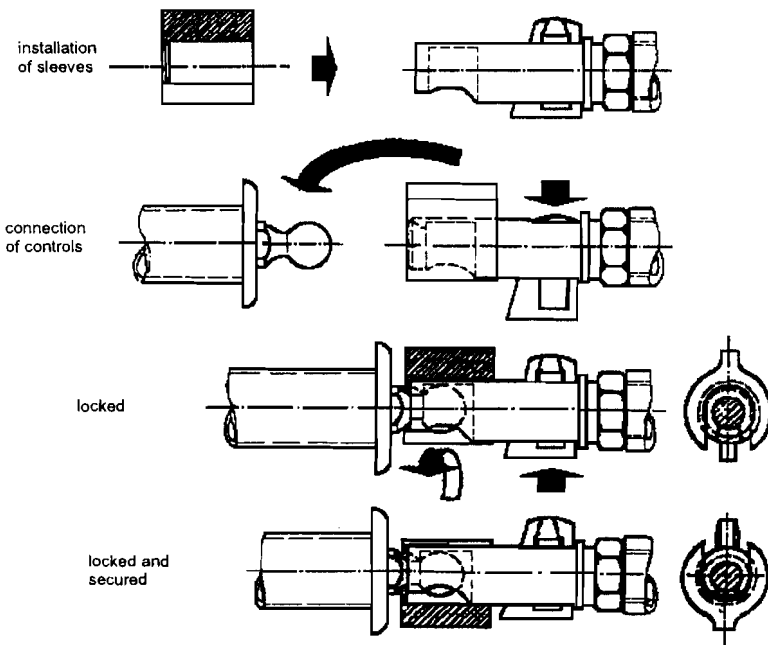

Attachment to Airworthiness Directive No. 1993-001/3
L'Hotellier ball and socket connector, lock plate
Attachment page 4 of 4

Section IV

L'Hotellier ball and socket connectors

Prior to the installation of ball and socket connectors, everyone has to familiarize himself with their functioning.

The socket is to be slid completely over the ball with the lock plate pressed down. During locking the lock plate moves back slightly so that in a correct connection the hole on the narrow edge of the lock plate becomes visible.

The safety pin is to be inserted in this hole thus securing the ball and socket connector.

Attention:

By loading the connection full engagement of the ball is to be verified!

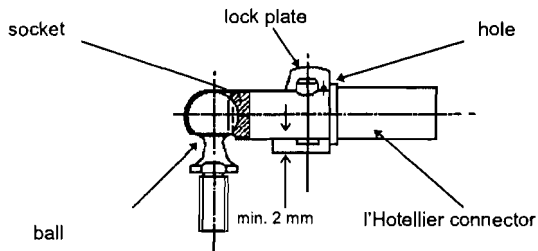

Warning!

Unsecured ball and socket connectors may open automatically in flight.