

ALEXANDER SCHLEICHER GmbH & Co, Segelflugzeugbau
D-6416 POPPENHAUSEN / WASSERKUPPE

FLIGHT MANUAL

FOR THE GLIDER MODEL

ASK 23 B

Data Sheet No. 353

Edition February 1985

This manual must be on board of the aircraft at any time !

It belongs to the glider ASK 23

Serial No.: **23048**

Registration letters: **F-CPVD**

Owner: **AAVA**

.....
.....

Manufacturer: Alexander Schleicher GmbH & Co.
Segelflugzeugbau
D-6416 Poppenhausen
Federal Republic of Germany.

The German original of this manual has been approved as Operating Instructions by the Luftfahrt-Bundesamt (LBA = Federal Office of Civil Aeronautics of the Fed. Rep. of Germany) according to Article 12 (1) 2 of the German LuftGerPO.

The translation has been done by best knowledge and judgement. In any case the original text in German language is authoritative.

Annexe 1



Cet intercalaire doit obligatoirement être inséré
devant la page de garde d'un manuel de vol en
langue anglaise

AVERTISSEMENT

Le présent document en langue anglaise est le manuel de vol approuvé par l'Agence européenne de la sécurité aérienne.

En application des dispositions de l'arrêté du 24 juillet 1991 relatif aux conditions d'utilisation des aéronefs civils en aviation générale (« Un vol ne peut être entrepris que si, d'une part les membres d'équipage sont familiarisés avec l'aéronef et son équipement de bord, notamment le matériel de sécurité-sauvetage et les systèmes spéciaux, et d'autre part ont une connaissance pratique de son manuel de vol ou des documents acceptés comme équivalents. »),

Nul ne peut utiliser l'aéronef avec ce seul document s'il n'a pas une connaissance suffisante de la langue anglaise.

A défaut, il appartient au propriétaire ou à l'exploitant de l'aéronef de se procurer une traduction de ce document sous sa responsabilité.

Référence : Instruction du 13/11/2009 relative à la langue des manuels de vol

I.2 INDEX OF CORRECTIONS

Cur. No.	Page Concerned	Designation or description	Acknowledgement, Date, Signature
01	28	Calibration of the on-board pressure system, subsequently supplemented	03.05.85 <i>J-to</i>
02	2a, 23a 23b	Amendment to the Flight Manual (TN No.6)	10.05.90 <i>R.W. J-to</i>
03	Annex	New production series tow release couplings for aerotow and winch launch (TN No 7)	01.03.90 <i>R.W. J-to</i>
04	2a, 33, 34, 35	Amendment to the Flight Manual (TN No.8)	04.12.90 <i>R.W. J-to</i>

DATE:

01.02.85

AUTHOR:

Kaiser

CORRECTION:

Cur. No.	Page Concerned	Designation or description	Acknowledgement, Date, Signature

DATE:
01.02.85

AUTHOR:
Kaiser

CORRECTION:

I.1.1 LIST OF PAGES INCLUDET

Chapter	Page	Date	Chapter	Page	Date
I	Title-	01.02.85	V	27	01.02.85
	paget			28	01.02.85
	1			29	01.02.85
	2			30	01.02.85
	2a			31	01.02.85
	3		VI	32	01.02.85
	4			33	26.11.90
5	34	26.11.90			
II	6	01.02.85	35	26.11.90	
	7	01.02.85			
	8	01.02.85			
	9	01.02.85			
	10	01.02.85			
	11	01.02.85			
	12	01.02.85			
III	13	01.02.85			
	14	01.02.85			
	15	01.02.85			
	16	01.02.85			
IV	17	01.02.85			
	18	01.02.85			
	19	01.02.85			
	20	01.02.85			
	21	01.02.85			
	22	01.02.85			
	23	01.02.85			
	23a	10.05.90			
	23b	10.05.90			
	24	01.02.85			
25	01.02.85				
	26	01.02.85			

Rev.no. Date Sig.
IN 8 26.11.90 Juw

Author Date
Jumtow 10.05.90

I.3. TABLE OF CONTENTSI. GENERAL INFORMATION

I.1.	Title Page	
I.2.	Index of corrections	Page 1
I.3.	Table of contents	Page 3
I.4.	Overall view	Page 5
I.5.	Three-view drawing	Page 6
I.6.	Description of the aircraft (Technical Data)	Page 7

The following section of the manual is that required by the JAR 22 Regulations and recognized by the LBA (= Federal Office of Civil Aeronautics of the Federal Republic of Germany).

II. OPERATIONAL FACTORS AND LIMITS

II.1.	Airworthiness category	Page 8
II.2.	Types of operation	Page 8
II.3.	Minimum equipment	Page 8
II.4.	Speed limits and limit loads	Page 9
II.5.	Crew	Page 10
II.6.	Masses	Page 10
II.7.	Limits of C.G. position in flight	Page 11
II.8.	C.G. position and load limits based on the last weighing	Page 11
II.9.	Mass trimming (trim weights) for light and heavy pilots	Page 13
II.10.	Extremes of pilot size	Page 15
II.11.	Tow rope weak link	Page 15
II.12.	Operating limitation information on placards and instruments in the cockpit	Page 15

III. EMERGENCY PROCEDURES

III.1.	Preventing and terminating the spin	Page 17
III.2.	Canopy jettisoning and emergency bail-out	Page 18
III.3.	Other emergencies	Page 18

DATE:
01.02.85

AUTHOR:
Kaiser

CORRECTION:

IV. NOTES ON NORMAL OPERATIONS

IV.1.	General information	Page 20
IV.2.	Explanation of the operating levers, placards and symbols in the cockpit	Page 20
IV.3.	Daily inspections	Page 22
IV.4.	Pre-flight checks	Page 22
IV.5.	Winch launching	Page 24
IV.6.	Aero-towing	Page 24
IV.7.	Free flight	Page 25
IV.8.	Dangerous flight attitudes	Page 25
IV.9.	Approach and landing	Page 25

End of the section of the manual required by the JAR 22 Regulations and recognized by the LBA.

V. FLIGHT PERFORMANCE

V.1.	General information	Page 27
V.2.	Level flight polar	Page 29
V.3.	Circling flight polar	Page 30
V.4.	Stalling speeds	Page 31

VI. RIGGING AND DE-RIGGING

VI.1.	Rigging	Page 32
VI.2.	De-rigging	Page 33
VI.3.	Storage	Page 34
VI.4.	Road transport	Page 34

DATE:

01.02.85

AUTHOR:

Kaiser

CORRECTION:

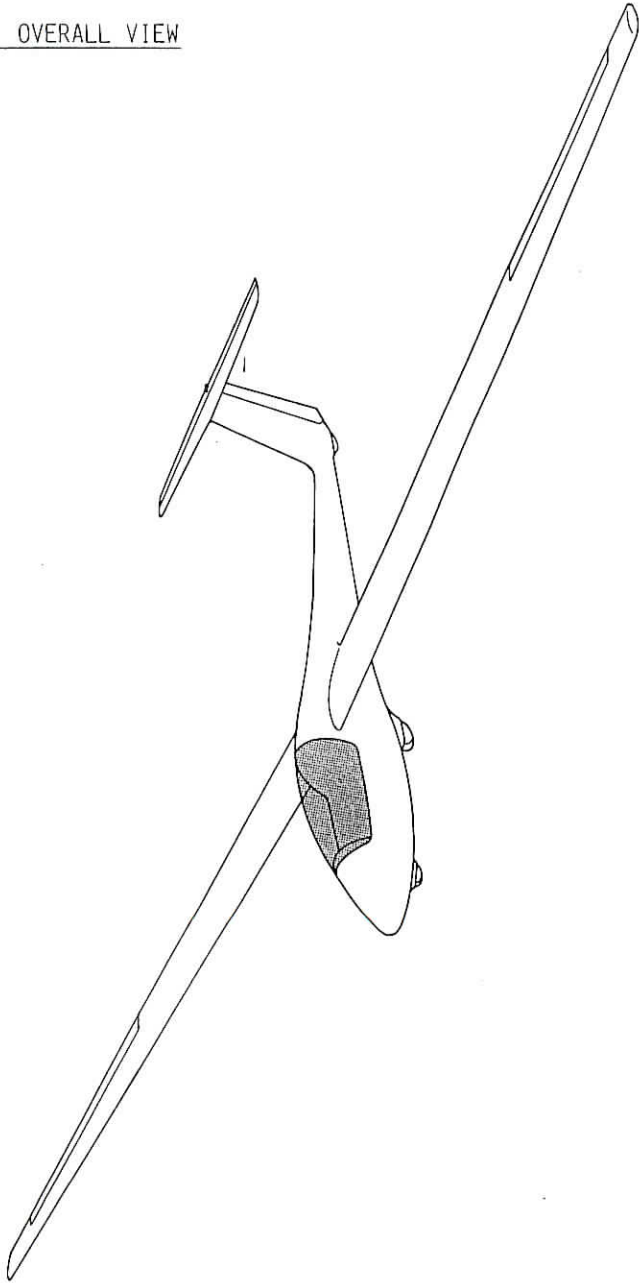
I.4. OVERALL VIEWDATE:
01.02.85AUTHOR:
Jumtow

CORRECTION:

I.5. THREE-VIEW DRAWING

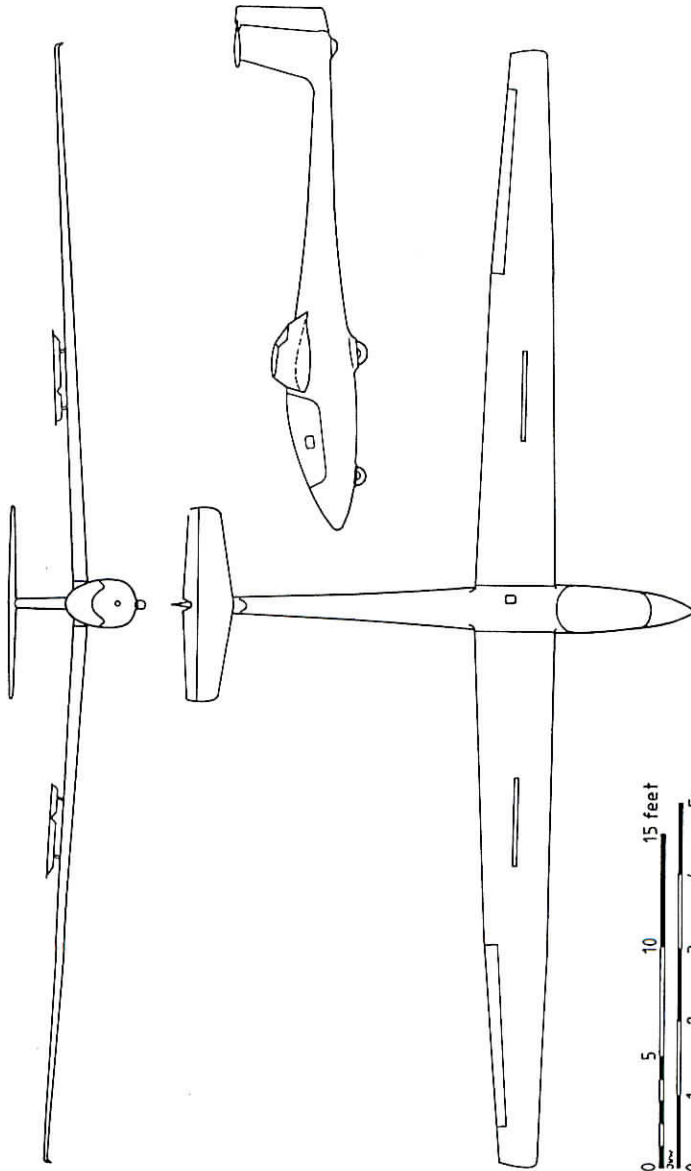

DATE:
01.02.85

AUTHOR:
Kaiser

CORRECTION:

I.6. DESCRIPTION OF THE AIRCRAFT

The ASK 23 is a single-seat performance glider in fiberglass construction. It is intended for use for first solo up to competition flights.

The ASK 23 is designed, built and type-approved in accordance with the JAR 22 Requirements, valid since March 15, 1982.

Note that the minimum safety factor is 1,5. The safety factor is the ratio of the ultimate load to the limit load.

Please regard that the safety margin is exceeded and ultimate loads are reached if the limit speeds are exceeded by only $\sqrt{1,5} = 1,22$ times. For this reason it is absolutely essential that the speed limits stated are observed.

As you can see, the safety factors are rather low. The basic assumption in all cases is that the aircraft are operated with the standard of care and attention which is usual in aviation.

Technical Data:

Wingspan:	15,00 m
Fuselage length:	7,05 m
Height (fin + tailskid):	1,40 m
Wing aspect ratio:	17,44
Wing area:	12,90 m ²
Max. flight mass:	360 kg
Max. wing loading:	29,46 kg/m ²
Min. wing loading:	~24,00 kg/m ²
Max. Landing Weight :	360 kg

DATE:
01.02.85

AUTHOR:
Kaiser

CORRECTION:

II. OPERATIONAL FACTORS AND LIMITS

II.1. AIRWORTHINESS CATEGORY

The ASK 23 is type-approved in the airworthiness category "U" (Utility).

Relevant construction regulations: Joint Airworthiness Requirements for sailplanes and powered sailplanes JAR 22, dated March 15, 1982, with Change 2 of Sept.13, 1983, in the English edition.

II.2. TYPES OF OPERATION

The ASK 23 may be flown in daylight according to VFR. Cloud flying in daylight and simple aerobatics are not permissible.

II.3. MINIMUM EQUIPMENT

- A.S.I. with measuring range of at least 50 ÷ 250 km/h (27 ÷ 135 kts)
- Altimeter
- Four-part safety harness
- Parachute, or backcushion at least 6 cm (2,4 in) thick when compressed.

A list of units tested and approved is included in the ASK 23 Maintenance Manual.

DATE: 01,02,85

AUTHOR: Kaiser

LBA APPROVAL

DATE:15,02,85

II.4. SPEED LIMITS AND LIMIT LOADS

Maximum permissible indicated airspeeds (IAS) at altitudes below 3000 m (9843 ft) NN*:

Max.permissible speed (VNE)	215 km/h	(116 kts)
With full control surface movements (maneuvering speed) (VM)	145 km/h	(78,25 kts)
In severe turbulence**	145 km/h	(78,25 kts)
On winch tow	125 km/h	(67,5 kts)
On aero tow	145 km/h	(78,25 kts)

*Note: Flutter testing was carried out at an altitude of approx. 2500 m NN (8202 ft). With increasing altitude the A.S.I. indicates too low; as it is the true airspeed which determines the flutter limit for light aircraft, the following table of limits applies for high-altitude flights:

Flight Altitude (above NN)		V_{max} indicated	
Meter	Feet	km/h	kts
0	0	215	116
1000	3281	215	116
2000	6562	215	116
3000	9843	215	116
4000	13123	204	110
5000	16404	193	104
6000	19685	183	98,75
8000	26247	163	88
10000	32809	145	78,25

If you observe these indicated airspeeds above 3000 m NN (9843 ft), the true flying speed will remain a constant 215 km/h (116 kts).

**Note: According to the Regulations the term "severe turbulence" means air movements which might be encountered in wave rotors, storm clouds, visible whirlwinds and when

DATE: 01.02.85

AUTHOR: Kaiser

LBA APPROVAL

DATE: 15.02.85

overflying mountain ranges and ridges.

At maneuvering speeds full control surface movements may still be applied, but with simultaneous elevator and rudder only 80 % of the full movements is allowed.

Maximum permissible recovery loads

Max. positive load + 5,3 g)
Max. negative load - 2,65g) at 145 km/h (78,25 kts)

With increasing speed the limits decrease linearly to:

Max. positive load + 4,0 g)
Max. negative load - 1,5 g) at 215 km/h (116 kts).

II.5. CREW

The crew of the ASK 23 is one pilot.

II.6. MASSES

According to the "Gesetz über Einheiten im Meßwesen" (= Weights and Measures Act) of July 2, 1969, the term "mass" is to be used where the kilogram (kg) is the unit, as opposed to the expression "weight" formerly used.

DATE: 01.02.85

AUTHOR: Kaiser

LBA APPROVAL

DATE: 15.02.85

Empty mass with min.equipment	about 240kg	(529 lbs)
Max. permissible flight mass	360kg	(838 lbs)
Max. permissible mass of the non-lifting structural parts	253kg	(558 lbs)

II.7. LIMITS OF C.G. POSITION IN FLIGHT

The Datum Point (= "Bezugspunkt" BP) is the leading edge of the wing root rib (disregarding the rounded part of the wing-fuselage transition).

The horizontal datum line is the center line of the fuselage tail cone, or a 1000 : 40 template placed horizontally on the top surface of the fuselage tail cone (see the section "Setting-up data" in the Maintenance Manual).

The permissible C.G. range in flight extends from 285 to 455 mm (11,2 to 17,9 in) aft of the BP.

The C.G. position in flight can be calculated from the empty mass C.G. position and the cockpit load (see Chapter III.2.4 in the Maintenance Manual).

II.8. C.G. POSITION AND LOAD LIMITS BASED ON THE LAST WEIGHING

The empty mass C.G. position is determined by weighing (see Chapter III.2.2 in the Maintenance Manual). As the permissible in flight C.G. position limits must not be exceeded, the empty mass and the empty mass C.G. position determine the permissible pilot weight range (see Chapter III.2.5 in the Maintenance Manual) which is entered on the following page.

DATE: 01.02.85
AUTHOR: Kaiser

LBA APPROVAL
DATE: 15.02.85

For this reason the aircraft must be weighed to establish the new C.G. position after all repairs, alterations in installed instrumentation etc. (see Maintenance Manual, Chapter III.2.5).

Date of weighing	Empty mass C.G.	Empty mass	Pilot weight m_p *incl. parachute Min. Max.	**Max.perm- missible load (m_{load})	Signature of inspector, insp. stamp

$$*m_p = m_{pilot} + m_{parachute}$$

$$**m_{load} = m_{pilot} + m_{parachute} + m_{baggage}$$

DATE: 01.02.85

AUTHOR: Kaiser

LBA APPROVAL

DATE: 15.02.85

If the pilot's weight is below the minimum, the shortfall below the minimum pilot weight must be made good by the addition of weight in the aircraft's nose (see also Chapter II.9.).

The load in the baggage compartment has no significant effect on the C.G. position. It must not, however, be loaded with more than 15 kg (33,1 lbs).

The place in front of both spar stubs in the fuselage is to be used as the baggage compartment. Baggage should be stored in soft bags if possible.

Hard objects weighing more than 1 kg (2,2 lbs) should be carefully lashed down in the baggage compartment in order to prevent accidents because they possibly may become high impact missiles. On customer request supports for rubber cords, barograph, batteries, etc. can be installed in the baggage compartment; these are available as an extra with Alexander Schleicher GmbH & Co.

II.9. MASS TRIMMING (TRIM WEIGHTS) FOR LIGHT AND HEAVY PILOTS

Light pilot:

The aircraft is trimmed in such a way that pilots with weight of up to 70 kg (154,3 lbs) (incl. parachute) achieve just the most rearward permissible C.G. position when having the backrest in the most forward position.

DATE: 01.02.85
AUTHOR: Kaiser

LBA APPROVAL
DATE: 15.02.85

Lighter pilots must fit trim lead discs in the fuselage nose for compensation.

One trim disc weighs 1 kg (2,2 lbs). Owing to the moment proportion one trim lead disc compensates a minimum mass of 1,74 kg (3,84 lbs).

The following table details the number of trim lead discs required.

Mass of Pilot and Parachute		Number of trim discs
kg	lbs	
70,0	154,3	0
68,3	150,6	1
66,5	146,6	2
64,8	142,9	3
63,0	138,9	4
61,3	135,1	5
59,6	131,4	6
57,8	127,4	7
56,1	123,7	8
54,3	119,7	9
52,6	116	10

Tall and heavy pilot:

The aircraft has a relatively long cockpit in order to accommodate in comfort also tall pilots.

For this purpose the backrest is adjustable to the back; the pilot moment arm consequently is reduced.

DATE: 01.02.85

AUTHOR: Kaiser

LBA APPROVAL

DATE: 15.02.85

II.10. EXTREMES OF PILOT SIZE

The cockpit room is sufficient to make the most forward stop at the backrest as the standard position. Slim pilots up to 185 cm height (6,07 ft) find sufficient room.

The rearward stops are provided for extremely tall and corpulent pilots.

In any case the pilot must fly with the backrest.

When flying without parachute, the pilot must use a back cushion which is at least 5 cm (2 in) thick when compressed.

All operating levers including the canopy emergency jettisoning lever must be easily accessible from each seat position, the pilot being firmly attached by the safety harness.

II.11. TOW ROPE WEAK LINK

For winch tow a weak link of maximum 680 daN (1500 lbs) is to be used; e.g. we recommend the new weak link 4 (blue paint finish; $600 \text{ daN} \pm 60 \text{ daN} = 1323 \text{ lbs} \pm 132 \text{ lbs}$).

For aero tow a weak link of maximum 490 daN (1080 lbs) is to be used; e.g. we recommend the new weak link 7 (green paint finish; $300 \text{ daN} \pm 30 \text{ daN} = 661 \text{ lbs} \pm 66 \text{ lbs}$).

II.12. OPERATING LIMITATION INFORMATION ON PLACARDS AND INSTRUMENTS IN THE COCKPIT

Airspeed indicator markings

Red radial line at 215 km/h (116 kts):

Max. permissible speed (VNE) below
3000 m (9843 ft) NN.

Green arc from 70 ÷ 145 km/h (37,75 ÷ 78,25 kts):

Permissible speed range in severe
turbulence.

DATE: 01.02.85
AUTHOR: Kaiser

LBA APPROVAL
DATE: 15.02.85

Yellow arc from 145 ÷ 215 km/h (78,25 ÷ 116 kts):

Permissible speed range (warning range) for turbulence up to 7,5 m/s (1476 ft/min) difference speed.

The yellow triangle \triangle at 80 km/h (43 kts) indicates the recommended approach speed for the landing.

Data placard and trim plan on the right cockpit wall:

<i>Alexander Schleicher GmbH & Co.</i>			
<i>Segelflugzeugbau, D-6416 Poppenhausen</i>			
<i>Model ASK 23</i>	<i>Serial-No. 23 xxx</i>		
<i>DATA PLACARD and LOADING SCHEME</i>			
<i>Empty weight</i>	<i>lbs</i>	<i>kg</i>	
<i>Max. all up weight</i>	<i>838 lbs</i>	<i>380 kg</i>	
<i>Max. cockpit payload</i>	<i>lbs</i>	<i>kg</i>	
<i>Min. cockpit payload</i>	<i>lbs</i>	<i>kg</i>	
<i>Max. speed for:</i>			
<i>winch launch</i>	<i>67,5 kts</i>	<i>125 km/h</i>	
<i>aero tow</i>	<i>78,25 kts</i>	<i>145 km/h</i>	
<i>maneuvering</i>	<i>78,25 kts</i>	<i>145 km/h</i>	
<i>Weak link for winch launch</i>	<i>540 up to 660 daN</i>		
<i>Weak link for aero tow</i>	<i>270 up to 330 daN</i>		
<i>Tire pressure:</i>	<i>Main wheel</i>	<i>42,7 psi</i>	<i>3,0 bar</i>
	<i>Nose wheel</i>	<i>28,4 psi</i>	<i>2,0 bar</i>
	<i>Tail wheel</i>	<i>35,6 psi</i>	<i>2,5 bar</i>

Baggage compartment placard on main bulkhead in front of baggage compartment:

Loading of baggage compartment
max. 15 kg (33 lbs)

Placard for interchangeable trim ballast

 *Check weight and proper fixing of trim discs prior to start.*

DATE: 01,02,85

AUTHOR: Kaiser

LBA APPROVAL

DATE: 15,02,85

III. EMERGENCY PROCEDURES

III.1. PREVENTING AND TERMINATING THE SPIN

The spin characteristics are essentially determined by the C.G. position.

The ASK 23 enters a spin only with the most aft permissible C.G. position.

Spinning is rather reluctantly and the aircraft comes out of the spin by itself after three turns. The spin is terminated immediately when applying normal elevator and aileron, and at the same time rudder in the opposite direction to the spin.

The height loss during initiating the recovery from the spin until complete recovery is about 100 m (328 ft).

Spiral dive

The spiral dive is frequently mistaken for the spin; and this involves a certain danger.

While the spin is entered at relatively low speed and with aft C.G. positions and with partly stalling airflow, the airflow attaches with the spiral dive.

During attempts to put the aircraft into a spin it happens rather frequently that the spin is initiated, however the aircraft does not continue the spin because of a too far forward C.G. position, but takes up a spiral dive. With the stick pulled back and with high speed the aircraft may become subject to accelerations which reach the limits of structural integrity.

In this case it is only good to pull the airbrakes in time and to flatten out gently.

DATE: 01.02.85

AUTHOR: Kaiser

LBA APPROVAL

DATE: 15.02.85

III.2. CANOPY JETTISONING AND EMERGENCY BAILING OUT

- a) Push to the left the horizontal lever with the red knob above the instrument panel cover and then push the canopy up and off.
- b) Disconnect safety harness.
- c) Get up and bail out.
When bailing out, push yourself away from the aircraft strongly. Be sure to avoid the tailplane !
- d) With manual parachutes catch rip cord handle and pull out entirely after 1 to 3 seconds.

III.3. OTHER EMERGENCIES

(1) Flights through precipitation

With wet or slightly iced wings or with insect accumulation there will be no marked deterioration in flight characteristics. However, the pilot has to reckon with a rather considerable deterioration in flight performance. This must be taken into account especially on landing final approach.

Add a safety margin of 10 km/h (5,4 kts) for approach speed !

(2) Ground looping

If it seems likely that the aircraft will run past the end of the intended landing area when landing, the pilot should initiate a controlled ground loop, at the latest about 40 m (130 ft) before the end of the landing area.

DATE: 01.02.85

AUTHOR: Kaiser

LBA APPROVAL

DATE: 15.02.85

- a) If possible, turn into the wind !
- b) At the same moment as the wing touches the ground, push the stick forward and apply opposite rudder !

(3) Emergency landings on water

Landings on water are very critical. According to the experience so far shown, it seems likely that the fuselage undercuts and in flat water strikes violently on the bottom.

Water depths less than 2 m (6,6 ft) are regarded as critical. The experience so far shown are not sufficient for giving generally accepted notes.

(4) Stall

The ASK 23 is extremely docile at the stall. Nevertheless, the pilot always has to face the possibility of wing dropping because of turbulence, etc. In that case push stick forward immediately and apply opposite rudder until normal flight attitude is regained.

DATE: 01.02.85

AUTHOR: Kaiser

LBA APPROVAL

DATE: 15.02.85

IV. NOTES ON NORMAL FLIGHT OPERATIONS

IV.1. GENERAL INFORMATION

In the first place the ASK 23 is intended for use for training school flying. Accordingly the aircraft is a simple design.

Flight characteristics are very docile.

IV.2. EXPLANATION OF THE OPERATING LEVERS, PLACARDS, AND SYMBOLS IN THE COCKPIT

Stick; with fitted transmitting button (as optional extra).

Rudder pedals, with fore and aft adjustment.



Pedal adjustment: grey knob to the right of the stick.

To reset the pedals further aft:

Unload the pedals and pull them back; then let the knob snap out of your hand, and apply a brief load to the pedals to lock them.

To reset the pedals further forward:

Pull the knob and press the pedals forwards with the heels; allow the knob to snap out of your hand, and apply a brief load to the pedals to lock them.

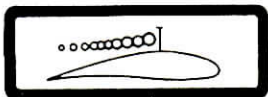

Airbrakes:
blue grip on the left cockpit wall; brakes extended by pulling.

DATE: 01.02.85

AUTHOR: Kaiser

LBA APPROVAL

DATE: 15.02.85

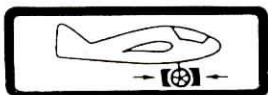

Wheelbrake:

the wheelbrake is operated by the final third of the movement of the airbrake lever.

Pull to brake !



Trim:

green lever on left cockpit wall.

Noseheavy trim: push forward green lever.



Tailheavy trim: pull back green lever.



Tow release:

Yellow knob on left front cockpit wall.



To open canopy:

white handles to the left and right on the canopy frame; pull them back.



Emergency canopy jettison:

red lever above the instrument panel. To jettison: push lever to the left.

For removing and assembling the canopy, see Maintenance Manual Chapter III.9.3.

DATE: 01.02.85

AUTHOR: Kaiser

LBA APPROVAL

DATE: 15.02.85



Ventilation;
on right cockpit wall.

Additional ventilation (as optional extra): airscoop in canopy window.

Anchoring point for parachute static line:
red ring on main bulkhead.



Serial number and type placard:
on main bulkhead to the right behind the pilot.

S.No. 23 xxx

Component placard on each component.

IV.3. DAILY INSPECTIONS AND

IV.4. PRE-FLIGHT CHECK

Rigging and de-rigging is carried out according to the instructions in the Flight Manual, pages 32 thru 33.

After rigging, check all control surfaces and check the airbrakes and wheelbrake.

Check tire pressure: main wheel 3 bar (42,7 psi); nose wheel 2,0 bar (28,4 psi); tail wheel 2,5 bar (35,6 psi) !

An aircraft stored in an hangar must also be subjected to a control surface check and careful inspection; aircraft

DATE: 01.02.85
AUTHOR: Kaiser

LBA APPROVAL
DATE: 15.02.85

stored in a hangar are subject to damage from shunting incidents and small animals.

Sun radiation

If the ASK 23 is stored on the airfield in sunlight, the canopy must not be opened up for a longer period of time (this is also valid prior to take-off when the pilot is already sitting in the glider); depending on the position of the sun and the intensity of the sunlight a scorch fire in the area of the instrument panel may result from the burning-glass effect of the canopy.

When parking the aircraft in the open air it is therefore absolutely necessary always to close the canopy and to cover it with a white cloth.

The following check list, which includes the most important points, is fitted on the left cockpit wall, in full view of the pilot:

Preflight Check

1. *Control connections, mainpins and bolts safetied?*
2. *Control check forcewise and*
3. *for clearance between controls and structure (gaps min. 1,5 mm sideways)?*
4. *Parachute static line connected?*
5. *Check pressure ports and probes?*
6. *Regard loading scheme?*

Prior to take-off:

1. *Parachute connected to harness?*
2. *Safety harness fastened?*
3. *Airbrakes locked?*
4. *Trim lever adjusted in starting position?*
5. *Altimeter adjusted?*
6. *What is the wind direction now!*
7. *Close your canopy now and lock white levers!*

DATE: 01.02.85

AUTHOR: Kaiser

LBA APPROVAL

DATE: 15.02.85

IV.3.1 DAILY INSPECTIONS

Refer also to Fig.IV.3.-1 !

- ①
 - Open canopy.
 - Check proper engagement of the main pins safety catch.
 - Check the aileron and airbrake connections inside the fuselage via the access hole. Do not forget to relock the access hole cover !
 - Check all control circuits force-wise and for their free moving over the entire range of movement; actuate the controls up to their stops and load the control circuits with fixed controls and airbrakes.
 - Check the tire pressures (see page 22).
 - Check the condition and function of the tow release mechanism. Engage and disengage the ring pair; check the automatic release of the towing hook: it must be possible to pull out the ring pair to the back.
 - Operate the wheelbrake. By pulling the airbrake lever you must feel an elastic resistance at the end of its travel and there must be still a gap of about 20 mm (0,79 in) between the hand lever and the seatpan cutout.
 - Carry out a check for foreign bodies !
- ②
 - Check top and bottom side of the wings for damages.
 - Ailerons: check for condition, free-moving travel, play and proper pushrod connection.
 - Airbrakes: check for condition and locking and for proper fit of the airbrake caps.
- ③
 - Check fuselage for damages - especially the underside.
- ④
 - Compensation tube: check the static pressure vents (on left & right side of the tail boom) for blockages and leaks.
- ⑤
 - Check the proper assembly of the horizontal tail and the nose bolt safety catch.
 - Check the automatic elevator connection and the rudder.

DATE: 01.02.86

LBA APPROVAL

AUTHOR: Juntow

DATE: 19.03.86

der actuation.

- Check tailskid wear plate or - if installed - pneumatic tail wheel.
- ⑥ - Check the pitot tube for blockages or leaks.

Fig.IV.3-1 Daily inspection round the glider

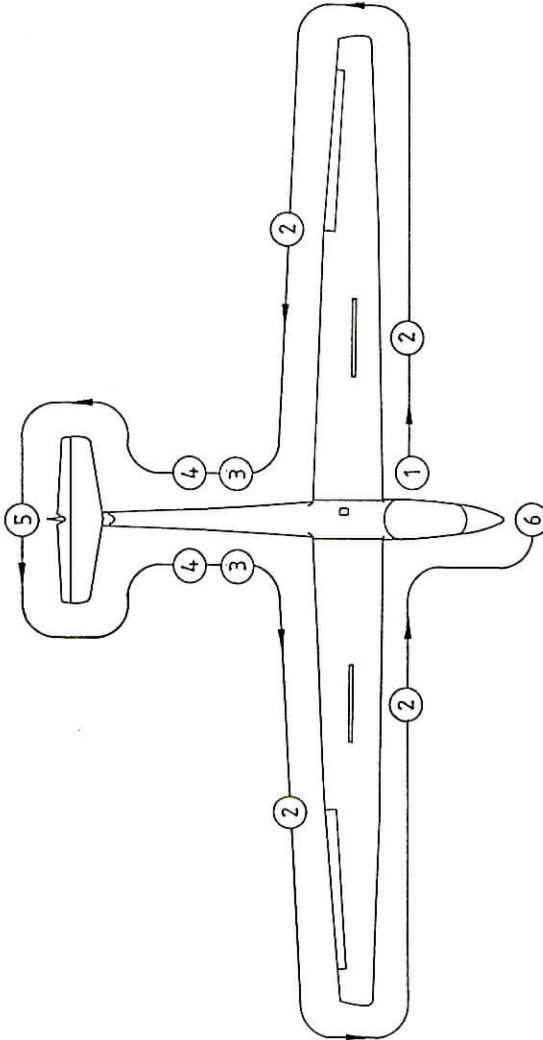

DATE: 01.02.86

AUTHOR: Juntow

LBA APPROVAL

DATE: 19.03.86

IV.5. WINCH LAUNCHING

Maximum permissible towing speed is 125 km/h (67,5 kts). With the trim in the center to slightly tail-heavy setting, the aircraft will lift off by itself, and will start climbing gently. Once a safety height has been reached, gentle-up elevator can be applied.

Maximum crosswind component: 25 km/h (13,5 kts).

IV.6. AERO-TOWING

Maximum permissible towing speed is 145 km/h (78,25 kts). The tested cable lengths (textile cable) are between 25 and 60 m (82 and 200 ft). On tow behind a powerful tug (180 PS or BHP) the cable length should be at least 40 m (130 ft).



Aero-towing is permissible on the nose towhook only !

Pilots should try to hold the tailskid on the ground until lift-off. This has many advantages: lift-off occurs at the earliest possible moment; the load on the landing gear is greatly reduced; directional stability during the ground-run is considerably increased.

After lift-off climb to 1 ÷ 2 m (3,3 ÷ 6,6 ft) in order to avoid pitch oscillations caused by ground effect and the tug aircraft's wake.

Maximum crosswind component: 25 km/h (13,5 kts).

DATE: 01.02.85

AUTHOR: Kaiser

LBA APPROVAL

DATE: 15.02.85

and especially if the pneumatic tailwheel is fitted. At the same time the extended airbrakes will aid stability in the crosswind. At about 40 ÷ 50 km/h (22 ÷ 27 kts) the airbrakes must then be retracted and locked.

If the aircraft ground loops during take-off owing to high grass etc., the pilot must release the two rope immediately.

IV.7. FREE FLIGHT

With maximum all-up weight the stall speed is 64,5 km/h (34,8 kts) IAS (≅ indicated airspeed).

The minimum speeds rise for turning flight. As a guide, you should reckon on an increase of 10 % at about 30° angle of bank, and 20 % at about 45° angle of bank.

A more accurate table is provided in Chapter V.4.

IV.8. DANGEROUS FLIGHT ATTITUDES

In Chapter III. "Emergency procedures" the dangerous flight attitudes are described.

IV.9. APPROACH AND LANDING

Approach is at about 80 km/h (43 kts).

In turbulent conditions it may be advisable to increase the approach speed still a little.

By operating the airbrakes, still relatively steep landing approaches may be carried out.

It is advisable to unlock the airbrakes already at the beginning of the landing approach.

DATE: 01.02.85

AUTHOR: Kaiser

LBA APPROVAL

DATE: 15.02.85

In addition the sideslip is also suitable as an approach control. With full rudder during sideslip the rudder pressure decreases to zero, therefore, the rudder must be pressed back when terminating.

DATE: 01.02.85
AUTHOR: Kaiser

LBA APPROVAL
DATE: 15.02.85

V. FLIGHT PERFORMANCE

V.1. GENERAL INFORMATION

A glider designed for the training of student flyers must feature docile flight characteristics. It must be able to fly at low speeds and must climb well, it must be easy to operate and it must have flight performances meeting today's standards. With the development of the ASK 23 all these characteristics have been taken into account.

The wing profile is designed appropriately for these tasks. In addition the aircraft has a very low wing loading for a fiberglass glider and this speaks well for a good performance in climb.

For all that the ASK 23 is not only good at low speeds. Also in the high speed range the ASK 23 offers outstanding performance.

It was only possible to achieve all this by using aerodynamic profiles on which quite a number of outstanding specialists have been working.

As in all probability often light pilots will be flying this aircraft, we give hereafter some information regarding C.G. positions and directional stability.

There is a close connection between C.G. position and directional stability. With a large aft C.G. position (only little mass in the front) the directional controllability of the aircraft becomes sensitive and it must be controlled with much more sense. For a student flyer this is not quite easy. Therefore, we recommend in such cases to fit rather a little more mass ballast, i.e. trim weights, than required by the minimum limit.

It is a good value to trim the aircraft in such a way that the in flight mass C.G. is approximately in the center of

DATE:
01.02.85

AUTHOR:
Kaiser

CORRECTION:

the permissible flight mass C.G. range. We do not recommend to have a too far forward C.G. position because this affects adversely the maximum lift.

For competition flights experienced pilots may easily use the most rearward C.G. positions. However, it is most beautiful to fly the aircraft with the center C.G. positions.

Calibration of the on-board pressure system

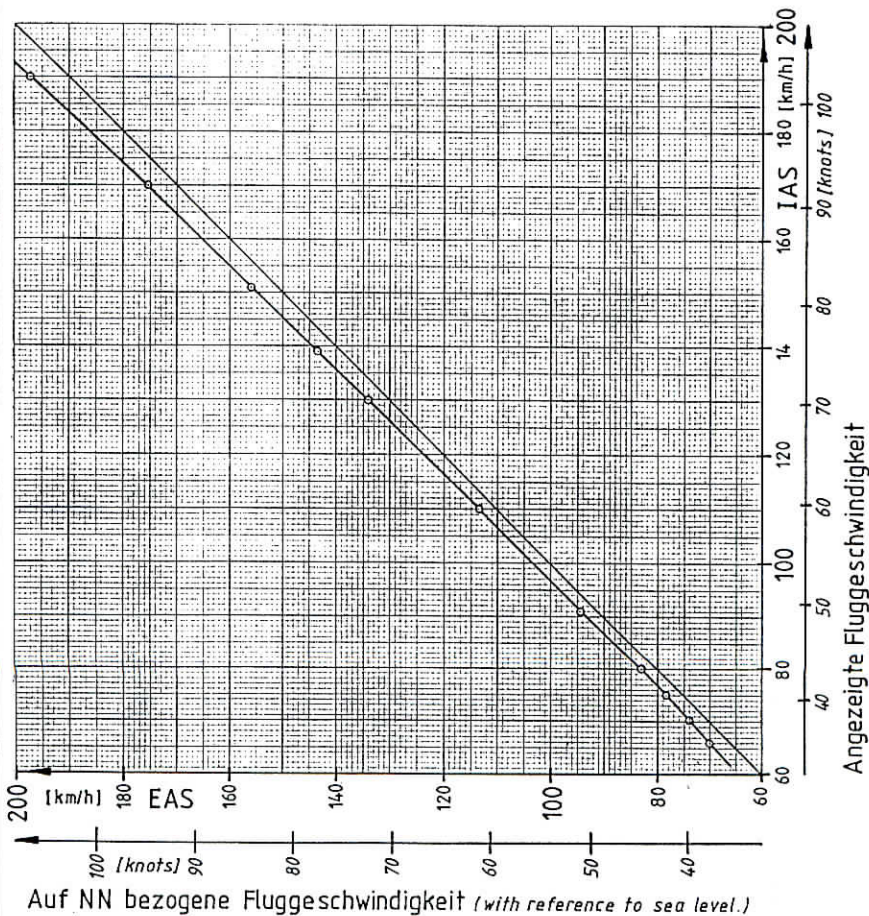

DATE:
01.02.85

AUTHOR:
Kaiser

CORRECTION:
03.05.85 Juntow

V.2. LEVEL FLIGHT POLAR

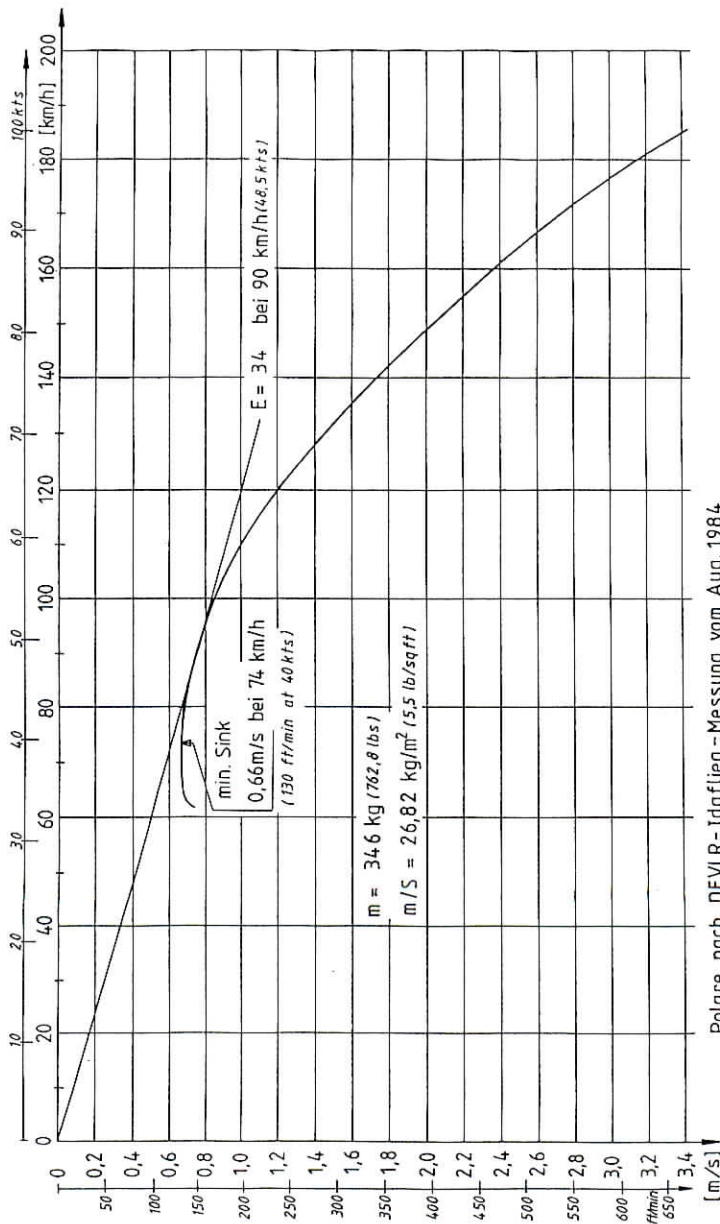

Polare nach DFVLR-Idaflieg - Messung vom Aug. 1984
POLAR CURVE ACCORDING TO DFVLR-IDAFLIEG-PERFORMANCE TEST OF AUG. 1984

DATE: 01.02.85

AUTHOR: Juntow

CORRECTION:

V.3. CIRCLING FLIGHT POLAR with flight mass of
340 kg (749,6 lbs)

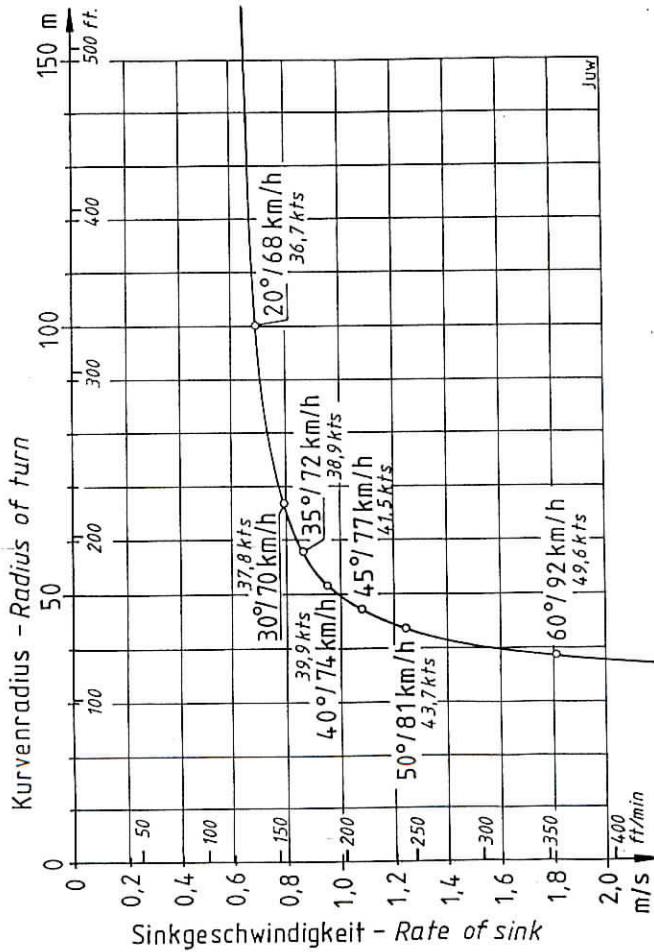

DATE:
01.02.85

AUTHOR:
Jumtow

CORRECTION:

V.4. STALLING SPEEDS

Notes:

1. The speeds stated apply to the aircraft in the aerodynamically clean state.
2. The indicating error of the on-board pressure system has been taken into consideration, while the error of the instrument is assumed to be zero.
3. The stall warning - buffeting of the tail - sets in at about 8 % above the stalling speeds.
4. Extending the airbrakes raises the stalling speeds in level flight by about 4 km/h (2,2 kts).

Diagram showing stalling speeds

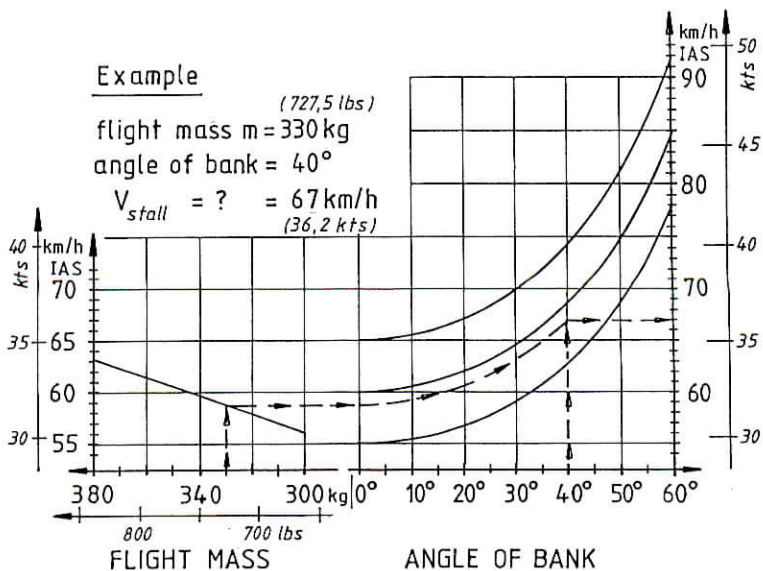

DATE:
01.02.85

AUTHOR:
Kaiser

CORRECTION:

VI. RIGGING AND DE-RIGGING

VI.1. RIGGING

Rigging the ASK 23 can be carried out by three persons without mechanical assistance, and by two persons with the use of a fuselage stand and a wing support.

1. Clean and grease all bolts and bushings and all control system connections.
2. Set up the fuselage and hold it vertical.
3. Fit the left wing (forked spar stub) into the fuselage from the side, then fit the right wing and bring the main bolt eyes into line. Press in the main bolts and lock. At this point only the wingtip supports can be removed.
4. Connect the ailerons and airbrakes, and satisfy yourself by pulling on the pushrods away from the heads that the four ball connectors are locked. If the aircraft should not be de-rigged for a long period of time, it is worthwhile securing the connectors with spring clips which are available from Alexander Schleicher GmbH & Co.

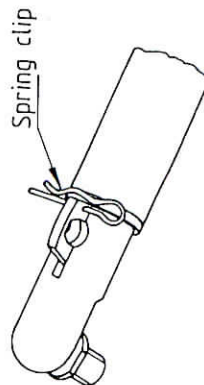
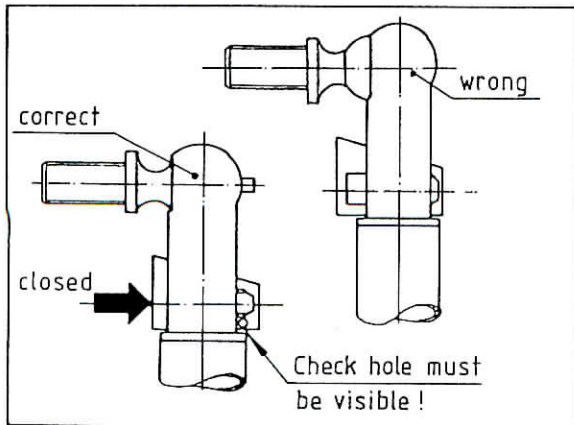

DATE:
01.02.85

AUTHOR:
Kaiser

CORRECTION:

5. Clean and grease carefully all connections!
6. Plug in the horizontal tail unit onto the fin from the front. At the same time the elevator automatically interconnects with the actuator (see Fig. VI.2-1 and VI.2-2). The tailplane is now pushed back until the Allan bolt at the leading edge can be screwed in; this should be screwed in tightly until the spring retainer snaps securely into place.
Check correct fit of the automatic elevator connection!
7. Taping up all the slots of the non-moving components at the wing separation points, using a plastic adhesive tape, provides a considerable gain in performance for little effort. Also the access hole cover on the fuselage as well as the tailplane/fin transition should be sealed in this way.
The canopy must not be taped up, otherwise emergency jettisoning of the canopy will be more difficult. We recommend that the areas to be taped should be thoroughly waxed beforehand so that the strips of tape can be removed again later without lifting off the paint.

VI.2. DE-RIGGING

De-rigging is carried out in the reverse sequence to that of rigging.

NOTE: When removing the tailplane, carefully push back the safety pin on the leading edge bolt with the hexagon wrench and spacer tube supplied, as otherwise it is easily bent when the bolt is unscrewed.

WARNING: For derigging the horizontal tail from the fin it has to be regarded that only the method according to Fig. VI.2-2 is used.

Rev. no.	Date	Sig.	Author	Date
TN 8	26.11.90	Juw	Kaiser	01.02.85

Fig. VI.2-1

WRONG: Twist movement

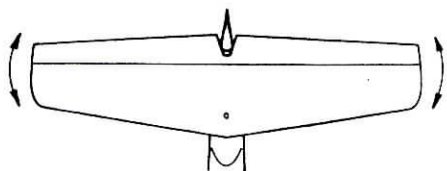
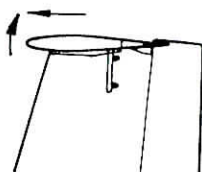

Fig. VI.2-2

RIGHT: Pitch movement



VI.3. STORAGE

Storing the aircraft in the open air can only be recommended if the weather conditions are likely to be perfect for the foreseeable future. You have to decide whether lashing the aircraft down, covering it up, and cleaning it before the next flight, involves more work than de-rigging and re-rigging.

To lash the wings down use arm braces (e.g. those used in the trailer) which will ensure that the wing control surfaces are not placed under load by the tie-down cables.

Holes for tie downs in the wingtips can be fitted on customer request as an optional extra.

If the aircraft is stored in a hangar for a protracted period, we recommend that you only cover the plexiglass canopy with a dust cover, as dust covers retain damp unnecessarily long in damp weather; and the damp can detract from the FRP material's ability to maintain its shape, and even its strength.

Rev.no.	Date	Sig.
TN 8	26.11.90	Juw

Author	Date
Kaiser	01.02.85

When storing the aircraft, be sure to remove all traces of food carried on board (chocolate, sweets, etc.) as it is our experience that such foodstuffs attract small animals which can cause damage to the interior and exterior of the aircraft.

VI.4. ROAD TRANSPORT

The addresses of manufacturers of trailers we have tested are available from Alexander Schleicher GmbH & Co.

In all cases it is important that the wings are located in close-fitting arm braces, or are supported at the spar stubs as close as possible to the root ribs.

Handling points on the fuselage are the tailskid, the main wheel and the nose wheel, and if necessary, the main wing pins (make up female supports from plastic, e.g. nylon), and the bulkhead immediately behind the nose wheel.

We cannot recommend an open trailer (even with an awning) for such a valuable aircraft. A closed trailer with plastic, metal or canvas skin is recommended; it must have surfaces of as light a color as possible, and have good ventilation when stationary, in order to avoid high temperatures and high humidity.

WARNING: In no case must the elevator actuator fitting be loaded. This fitting trades out of the upper end of the fin. Not even soft foam cushions are allowed.

For the construction of the trailer for road transport the full freedom from any load must be carefully regarded.

Rev.no.	Date	Sig.
TN 8	26.11.90	Juw

Author	Date
Kaiser	01.02.85

SHEET:
1 of 1

Technical Note
for

Alexander Schleicher
GmbH & Co.
Segelflugzeugbau
D-6416 Poppenhausen

Glider model:

ASK 18, ASK 18B	TN-No. 7
ASW 19, ASW 19B	TN-No. 23
ASW 20/20L, ASW 20B/20BL, ASW 20C/20CL	TN-No. 34
ASK 21	TN-No. 21
ASW 22	TN-No. 6
ASK 23, ASK 23B	TN-No. 7
ASH 25,	TN-No. 4

Subject:

New production series tow release couplings for aerotow and winch launch.

Serial number applicability:

ASK 18/18B,	Data Sheet No. L-307,	all serial no.s
ASW 19/19B,	Data Sheet No. L-308,	all serial no.s
ASW 20/20L,	Data Sheet No. L-314,	all serial no.s
ASW 20B/20BL,	Data Sheet No. L-314,	all serial no.s
ASW 20C/20CL,	Data Sheet No. L-314,	all serial no.s
ASK 21,	Data Sheet No. L-339,	all serial no.s
ASW 22,	Data Sheet No. L-351,	all serial no.s
ASK 23/23B,	Data Sheet No. L-353,	all serial no.s
ASH 25,	Data Sheet No. 04.364,	all serial no.s

Compliance:

None; applicable to new built gliders and in case of replacement of tow release couplings.

Reason:

According to the company TOST they have stopped the previous production series of the tow release couplings "Nose tow release coupling E 72/75" and "Safety tow release coupling G 72/73". These have been replaced by the new tow release coupling productions series "Nose tow release coupling E 85" and "Safety tow release coupling Europa G 88". In order to guarantee a problem-free exchange of the previous productions series against the new one, the new tow release couplings show externally almost no differences.

Action:

1. Where replacement is required or where a corresponding installation location is provided the new tow release coupling production series can be installed instead of the previous ones.
2. When this mod is accomplished, a copy of this Technical Note must be inserted as Annex into the Flight and Maintenance Manual of the glider (Operations Manuals respectively). The accomplishment of this action must be entered into the corresponding table in the manuals (the table headline reads: Additions to.., Amendments to .., Record or Log of Revisions ..).

Notes:

The glider owners must regard the "Operating and Maintenance Instructions" for the new production series tow release couplings issued by TOST and giving the service time until the next overhaul !

Poppenhausen, January 17, 1990

ALEXANDER SCHLEICHER

GmbH & Co.
A. Schleicher
Lütz-W. Juntow

The German original of this Technical Note has been approved by the LBA under the date of March 1, 1990 (signature: SCHMALJOHANN). The translation into English has been done by best knowledge and judgement; in any case of doubt the German original is controlling.

Weilergrube sowie Verwallung dieser Unterlagen. Verwallung und Mitterlung eines Inhalts nicht gestattet, soweit nicht ausdrücklich zugestanden. Zweifelsdungen, verhalten zu Schaden: Satz. Alle Rechte für den Fall der Patentierung oder Gebrauchsmuster-Eintragung vorbehalten.